

# Voltage Transducer LV 100-600/SP6

For the electronic measurement of voltages: DC, AC, pulsed..., with galvanic separation between the primary circuit and the secondary circuit.

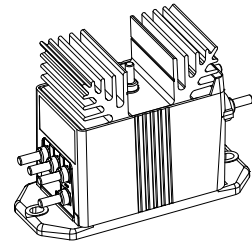

$$U_{PN} = 600 \text{ V}$$



## Electrical data

$U_{PN}$	Primary nominal RMS voltage	600	V
$U_{PM}$	Primary voltage, measuring range	0 ... $\pm 900$	V
$I_{PN}$	Primary nominal RMS current	16.66	mA
$R_M$	Measuring resistance with $\pm 15 \text{ V}$	@ $\pm 600 \text{ V}_{\text{max}}$	$R_{M \text{ min}}$ 0 $R_{M \text{ max}}$ 210 $\Omega$
		@ $\pm 900 \text{ V}_{\text{max}}$	0    120 $\Omega$
	with $\pm 24 \text{ V}$	@ $\pm 600 \text{ V}_{\text{max}}$	0    410 $\Omega$
		@ $\pm 900 \text{ V}_{\text{max}}$	110    250 $\Omega$
$I_{SN}$	Secondary nominal RMS current	50	mA
$S$	Sensitivity	83.33	$\mu\text{A/V}$
$U_C$	Supply voltage ( $\pm 5 \%$ )	$\pm 15 \dots 24$	V
$I_C$	Current consumption	$< 37$ (@ $\pm 24 \text{ V}$ ) + $I_S$	mA

## Accuracy - Dynamic performance data

$\epsilon_{\text{tot}}$	Total error @ $U_{PN}, T_A = 25 \text{ }^\circ\text{C}$	$\pm 0.9$	%
$\epsilon_L$	Linearity error	$< 0.1$	%
$I_O$	Offset current @ $U_p = 0, T_A = 25 \text{ }^\circ\text{C}$	Typ $\pm 0.2$ Max $\pm 0.2$	mA
$I_{OT}$	Temperature variation of $I_O$ $-40 \text{ }^\circ\text{C} \dots +85 \text{ }^\circ\text{C}$	$\pm 0.4$ $\pm 1.0$	mA
$t_{D90}$	Delay time to 90 % of the final value for $U_{PN}$ step	$< 40$	$\mu\text{s}$

## General data

$T_A$	Ambient operating temperature	$-40 \dots +85$	$^\circ\text{C}$
$T_{A \text{ st}}$	Ambient storage temperature	$-45 \dots +90$	$^\circ\text{C}$
$N_p/N_s$	Turns ratio	6000 : 2000	
$P_p$	Total primary power loss	10	W
$R_p$	Resistance of primary winding @ $T_A = 25 \text{ }^\circ\text{C}$	36	k $\Omega$
$R_s$	Resistance of secondary winding @ $T_A = 85 \text{ }^\circ\text{C}$	57	$\Omega$
$m$	Mass Standard <sup>1)</sup>	790 EN 50155: 2017	g

Note: <sup>1)</sup> Additional information available on request.

## Features

- Closed loop (compensated) voltage transducer using the Hall effect
- Insulating plastic case recognized according to UL 94-V0
- Primary resistor – incorporated within the housing.

## Special features

- $U_C = \pm 15 \dots 24$  ( $\pm 10 \%$ ) V
- $T_A = -40 \text{ }^\circ\text{C} \dots +85 \text{ }^\circ\text{C}$
- VRT Burn-in
- Shield between primary and secondary
- Connection to secondary circuit on M5 threaded studs.

## Advantages

- Excellent accuracy
- Very good linearity
- Low temperature drift
- Optimized delay time
- Wide frequency bandwidth
- High immunity to external interference.

## Applications

- Single or three phase inverters
- Propulsion and braking choppers
- Propulsion converters
- Auxiliary converters
- Battery chargers.

## Application Domain

- Railway (fixed installations and onboard).

**Voltage Transducer LV 100-600/SP6**

**Insulation coordination**

$U_d$	RMS voltage for AC insulation test, 50 Hz, 1 min	6 <sup>2)</sup> 1 <sup>3)</sup> Min	kV
$d_{cp}$	Creepage distance	55.12	mm
$d_{cl}$	Clearance	27.9	mm
$CTI$	Comparative tracking index (group I)	600	

**Notes:** <sup>2)</sup> Between primary and secondary + shield + heatsink  
<sup>3)</sup> Between shield and secondary + heatsink.

**Safety**



This transducer must be used in electric/electronic equipment with respect to applicable standards and safety requirements in accordance with the manufacturer’s operating instructions.



Caution, risk of electrical shock

When operating the transducer, certain parts of the module can carry hazardous voltage (e.g. primary connections, power supply). Ignoring this warning can lead to injury and/or cause serious damage. This transducer is a build-in device, whose conducting parts must be inaccessible after installation. A protective housing or additional shield could be used. Main supply must be able to be disconnected.

### Dimensions LV 100-600/SP6 (in mm)

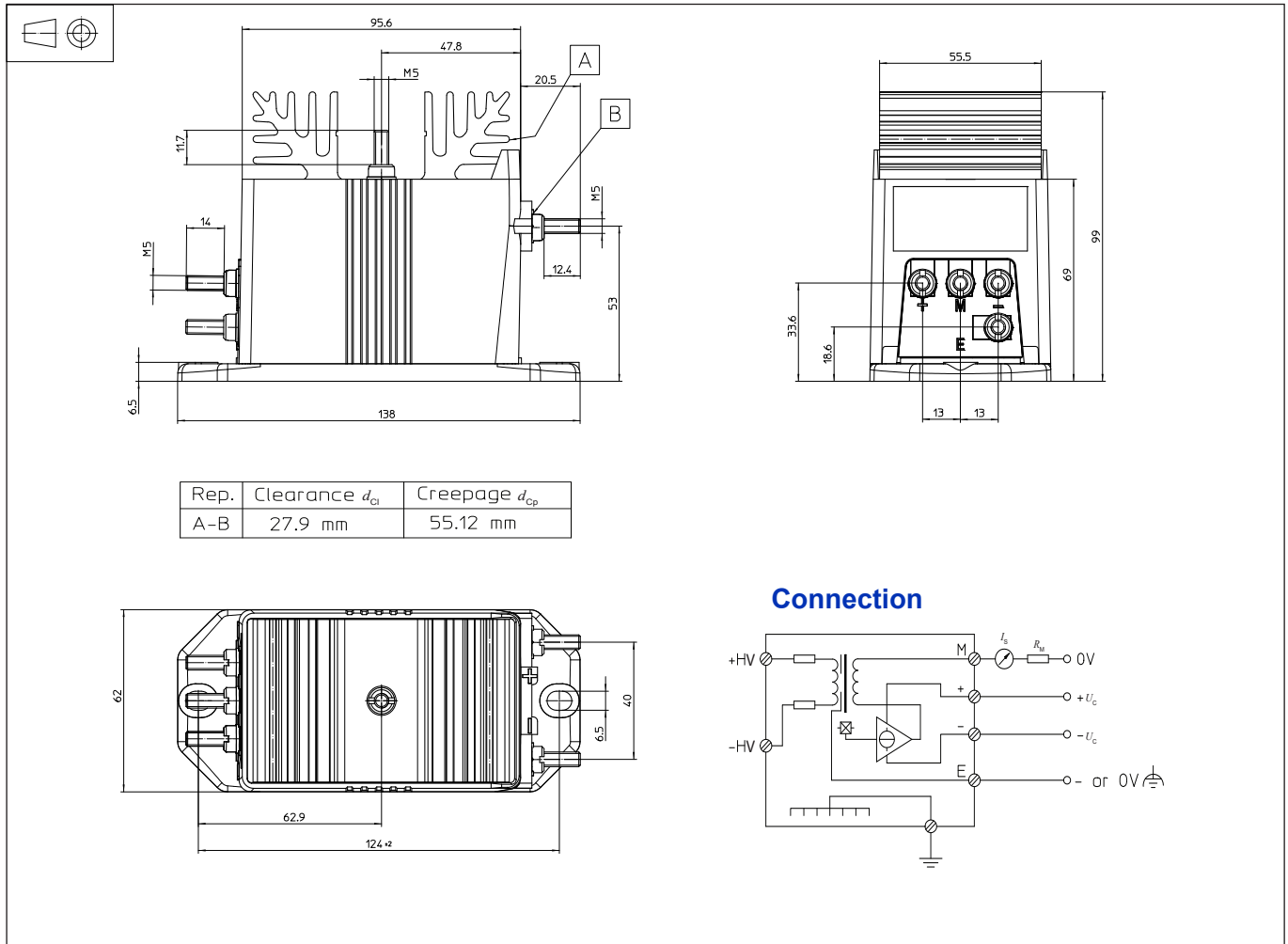

### Connection

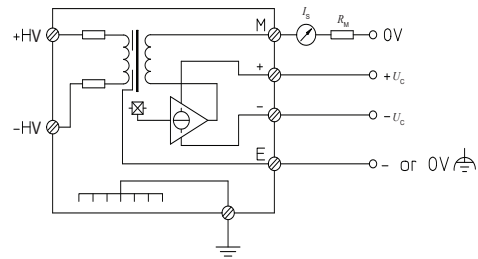

### Mechanical characteristics

- General tolerance  $\pm 0.5$  mm
- Transducer fastening
  - 2 holes  $\varnothing 6.5$  mm
  - 2 M6 steel screws
  - Recommended fastening torque 5 N·m
- Connection of primary
  - 2 M5 threaded studs
  - Recommended fastening torque 2.2 N·m
- Connection of secondary
  - 4 M5 threaded studs
  - Recommended fastening torque 2.2 N·m
- Connection of ground
  - M5 threaded stud
  - Recommended fastening torque 2.2 N·m

### Remarks

- $I_s$  is positive when  $U_p$  is applied on terminal +HV.
- The primary circuit of the transducer must be linked to the connections where the voltage has to be measured.
- Installation of the transducer must be done unless otherwise specified on the datasheet, according to LEM Transducer Generic Mounting Rules. Please refer to LEM document N°ANE120504 available on our Web site: <https://www.lem.com/en/file/3137/download/>.

单击下面可查看定价，库存，交付和生命周期等信息

[>>LEM\(莱姆\)](#)