

# Current Transducer LF 505-S

**$I_{PN} = 500 \text{ A}$**

For the electronic measurement of currents: DC, AC, pulsed..., with a galvanic isolation between the primary circuit (high power) and the secondary circuit (electronic circuit).



16137

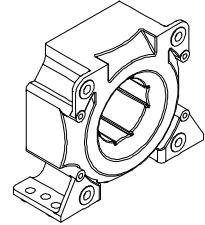

## Electrical data

$I_{PN}$	Primary nominal current rms	500	A		
$I_{PM}$	Primary current, measuring range	0 .. $\pm 800$	A		
$R_M$	Measuring resistance	$R_{M \text{ mini}}$	$R_{M \text{ maxi}}$		
				with $\pm 15 \text{ V}$	@ $\pm 500 \text{ A}_{\text{maxi}}$
		@ $\pm 800 \text{ A}_{\text{maxi}}$	0	11	$\Omega$
	with $\pm 18 \text{ V}$	@ $\pm 500 \text{ A}_{\text{maxi}}$	0	92	$\Omega$
		@ $\pm 800 \text{ A}_{\text{maxi}}$	0	30	$\Omega$
	with $\pm 24 \text{ V}$	@ $\pm 500 \text{ A}_{\text{maxi}}$	5	149	$\Omega$
	@ $\pm 800 \text{ A}_{\text{maxi}}$	5	65	$\Omega$	
$I_{SN}$	Secondary nominal current rms	100	mA		
$K_N$	Conversion ratio	1 : 5000			
$V_C$	Supply voltage ( $\pm 5 \%$ )	$\pm 15 \dots 24$	V		
$I_C$	Current consumption ( $\pm 1 \text{ mA}$ )	$24 (@ \pm 18 \text{ V}) + I_S$	mA		

## Features

- Closed loop (compensated) current transducer using the Hall effect
- Isolated plastic case recognized according to UL 94-V0.

## Advantages

- Excellent accuracy
- Very good linearity
- Low temperature drift
- Optimized response time
- Wide frequency bandwidth
- No insertion losses
- High immunity to external interference
- Current overload capability.

## Accuracy - Dynamic performance data

$X$	Accuracy @ $I_{PN}, T_A = 25^\circ\text{C}$	$\pm 0.6$	%
$\epsilon_L$	Linearity error	$< 0.1$	%
$I_O$	Offset current @ $I_P = 0, T_A = 25^\circ\text{C}$	Typ	$\pm 0.4$ mA
		Maxi	$\pm 0.4$ mA
$I_{OM}$	Magnetic offset current @ $I_P = 0$ and specified $R_M$ , after an overload of $3 \times I_{PN}$		$\pm 0.2$ mA
$I_{OT}$	Temperature variation of $I_O$ - $40^\circ\text{C} \dots +70^\circ\text{C}$	$\pm 0.1$	$\pm 0.4$ mA
$t_r$	Response time <sup>1)</sup> to 90 % of $I_{PN}$ step	$< 1$	$\mu\text{s}$
$di/dt$	di/dt accurately followed	$> 100$	A/ $\mu\text{s}$
$BW$	Frequency bandwidth (-1 dB)	DC .. 100	kHz

## Applications

- AC variable speed drives and servo motor drives
- Static converters for DC motor drives
- Battery supplied applications
- Uninterruptible Power Supplies (UPS)
- Switched Mode Power Supplies (SMPS)
- Power supplies for welding applications.

## General data

$T_A$	Ambient operating temperature	-40 .. +70	$^\circ\text{C}$
$T_S$	Ambient storage temperature	-40 .. +85	$^\circ\text{C}$
$R_S$	Secondary coil resistance	@ $T_A = 70^\circ\text{C}$	70 $\Omega$
$m$	Mass		230 g
	Standards		EN 50155: 1995 EN 50178: 1997

## Applications domain

- Traction
- Industrial.

Note: <sup>1)</sup> With a di/dt of 100 A/ $\mu\text{s}$ .

## Current Transducer LF 505-S

### Isolation characteristics

$V_{d,rms}$	Rms voltage for AC isolation test, 50 Hz, 1 min	3.8	kV
$\hat{V}_w$	Impulse withstand voltage 1.2/50 $\mu$ s	12.5	kV
		Mini	
dCp	Creepage distance	15.2	mm
dCl	Clearance distance	14.5	mm
CTI	Comparative Tracking Index (Group IIIa)	175	

### Application examples

According to EN 50178 and CEI 61010-1 standards and following conditions:

- Over voltage category OV 3
- Pollution degree PD2
- Non-uniform field

	EN 50178	CEI 61010-1
dCp, dCl, $\hat{V}_w$	Rated isolation voltage	Nominal voltage
Single isolation	1250 V	1250 V rms
Reinforced isolation	690 V	690 V rms

### Safety



This transducer must be used in electric/electronic equipment with respect to applicable standards and safety requirements in accordance with the manufacturer's operating instructions.



Caution, risk of electrical shock

When operating the transducer, certain parts of the module can carry hazardous voltage (eg. primary busbar, power supply).

Ignoring this warning can lead to injury and/or cause serious damage.

This transducer is a built-in device, whose conducting parts must be inaccessible after installation.

A protective housing or additional shield could be used.

Main supply must be able to be disconnected.

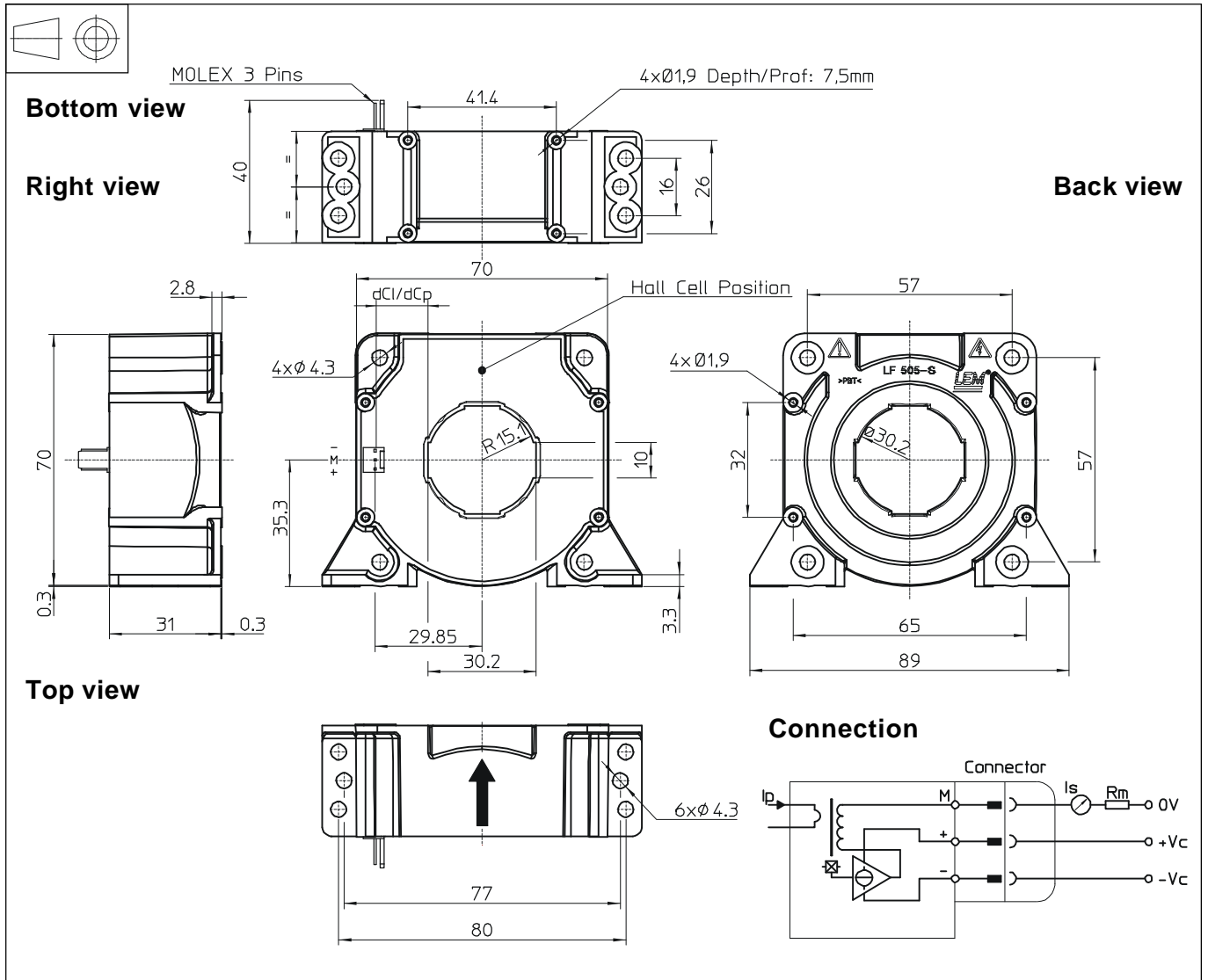
**Dimensions LF 505-S** (in mm. 1 mm = 0.0394 inch)

**Mechanical characteristics**

- General tolerance  $\pm 0.5$  mm
- Transducer fastening
  - Vertical or flat lying position 4 or 6 holes  $\varnothing 4.3$  mm
  - 4 or 6 steel screws M4
  - Recommended fastening torque or vertical position 3.2 Nm or 2.37 Lb.-Ft.
  - 4 holes  $\varnothing 1.9$  mm, depth : 7.5 mm
  - 4 screws PTKA 25, length: 6 mm
  - Recommended fastening torque or flat lying position 0.7 Nm or 0.52 Lb.-Ft.
  - 4 holes  $\varnothing 1.9$  mm, crossing
  - 4 screws PTKA 25, length:10 mm
  - Recommended fastening torque 0.75 Nm or 0.55 Lb.-Ft.
- Primary through-hole  $\varnothing 30.2$  mm
- Connection of secondary MOLEX 6410
- 3 Tin plated pins

**Remarks**

- $I_s$  is positive when  $I_p$  flows in the direction of the arrow.
- Temperature of the primary conductor should not exceed 100°C.
- Dynamic performances (di/dt and response time) are best with a single bar completely filling the primary hole.
- This is a standard model. For different versions (supply voltages, turns ratios, unidirectional measurements...), please contact us.

单击下面可查看定价，库存，交付和生命周期等信息

[>>LEM\(莱姆\)](#)