

# Current Transducer LA 55-TP/SP27

For the electronic measurement of currents: DC, AC, pulsed..., with galvanic separation between the primary circuit and the secondary circuit.

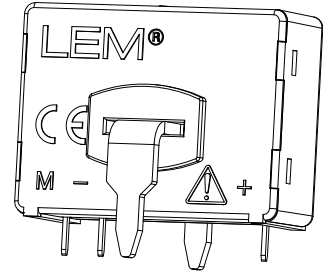

$$I_{PN} = 50 \text{ A}$$



## Electrical data

$I_{PN}$	Primary nominal RMS current	50	A			
$I_{PM}$	Primary current, measuring range	0 ... $\pm 100$	A			
$R_M$	Measuring resistance @ $T_A = 85^\circ\text{C}$	$R_{M \min}$	$R_{M \max}$			
				with $\pm 12 \text{ V}$	@ $\pm 50 \text{ A}_{\max}$	0
		with $\pm 15 \text{ V}$	@ $\pm 100 \text{ A}_{\max}$	0	30	$\Omega$
		with $\pm 15 \text{ V}$	@ $\pm 50 \text{ A}_{\max}$	30	320	$\Omega$
		@ $\pm 100 \text{ A}_{\max}$	30	90	$\Omega$	
$I_{SN}$	Secondary nominal RMS current	25	mA			
$N_P/N_S$	Turns ratio	1 : 2000				
$U_C$	Supply voltage ( $\pm 5\%$ )	$\pm 12 \dots 15$	V			
$I_C$	Current consumption ( $\pm 2$ )	10 (@ $\pm 15 \text{ V}$ ) + $I_S$	mA			

## Accuracy - Dynamic performance data

$\varepsilon$	Error @ $I_{PN}, T_A = 25^\circ\text{C}$	@ $\pm 15 \text{ V}$ ( $\pm 5\%$ )	$\pm 0.65$	%
		@ $\pm 12 \dots 15 \text{ V}$ ( $\pm 5\%$ )	$\pm 0.90$	%
$\varepsilon_L$	Linearity error		< 0.15	%
$I_O$	Offset current @ $I_P = 0, T_A = 25^\circ\text{C}$	Typ		Max
				$\pm 0.1$
$I_{OM}$	Magnetic offset current <sup>1)</sup> @ $I_P = 0$ and specified $R_M$ , after an overload of $3 \times I_{PN}$			$\pm 0.2$
				mA
$I_{OT}$	Temperature variation of $I_O$	-25 $^\circ\text{C}$ ... +85 $^\circ\text{C}$	$\pm 0.1$	$\pm 0.3$
		-40 $^\circ\text{C}$ ... -25 $^\circ\text{C}$	$\pm 0.2$	$\pm 0.5$
$t_{D10}$	Delay time @ 10 % of $I_{PN}$		< 500	ns
$t_{D90}$	Delay time to 90 % of $I_{PN}$ <sup>2)</sup>		< 1	$\mu\text{s}$
$BW$	Frequency bandwidth (-1 dB)		DC ... 200	kHz

## General data

$T_A$	Ambient operating temperature	-40 ... +85	$^\circ\text{C}$
$T_S$	Ambient storage temperature	-50 ... +90	$^\circ\text{C}$
$R_S$	Resistance of secondary winding @ $T_A = 85^\circ\text{C}$	150	$\Omega$
$m$	Mass	35	g
	Standards	EN 50155: 1995	
		UL 508: 2010	

Notes: <sup>1)</sup> Result of the coercive field of the magnetic circuit

<sup>2)</sup> For a  $di/dt = 100 \text{ A}/\mu\text{s}$ .

## Features

- Closed loop (compensated) current transducer using the Hall effect
- Insulating plastic case recognized according to UL 94-V0.

## Special features

- $I_{PM} = 0 \dots \pm 100 \text{ A}$
- $N_P/N_S = 1 : 2000$
- $U_d = 3.6 \text{ kV}$  (to see page 2)
- $T_A = -40^\circ\text{C} \dots +85^\circ\text{C}$
- Potted.

## Advantages

- Excellent accuracy
- Very good linearity
- Low temperature drift
- Optimized response time
- Wide frequency bandwidth
- No insertion losses
- High immunity to external interference
- Current overload capability.

## Applications

- AC variable speed drives and servo motor drives
- Static converters for DC motor drives
- Battery supplied applications
- Uninterruptible Power Supplies (UPS)
- Switched Mode Power Supplies (SMPS)
- Power supplies for welding applications.

## Application domain

- Traction.

## Current Transducer LA 55-TP/SP27

### Insulation coordination

$U_d$	RMS voltage for AC insulation test, 50 Hz/1 min	3.6	kV
$U_{Ni}$	Impulse withstand voltage 1.2/50 $\mu$ s	7.5	kV
		Min	
$d_{Cp}$	Creepage distance <sup>1)</sup>	8.3	mm
$d_{Cl}$	Clearance <sup>2)</sup>	8.3	mm
$CTI$	Comparative tracking index (group I)	600	

**Notes:** <sup>1)</sup> Distance between hole busbar and winding

<sup>2)</sup> Direct distance between hole busbar and winding.

### Safety



This transducer must be used in electric/electronic equipment with respect to applicable standards and safety requirements in accordance with the manufacturer's operating instructions.



Caution, risk of electrical shock

When operating the transducer, certain parts of the module can carry hazardous voltage (eg. primary busbar, power supply).

Ignoring this warning can lead to injury and/or cause serious damage.

This transducer is a build-in device, whose conducting parts must be inaccessible after installation.

A protective housing or additional shield could be used.

Main supply must be able to be disconnected.

## Dimensions LA 55-TP/SP27 (in mm)

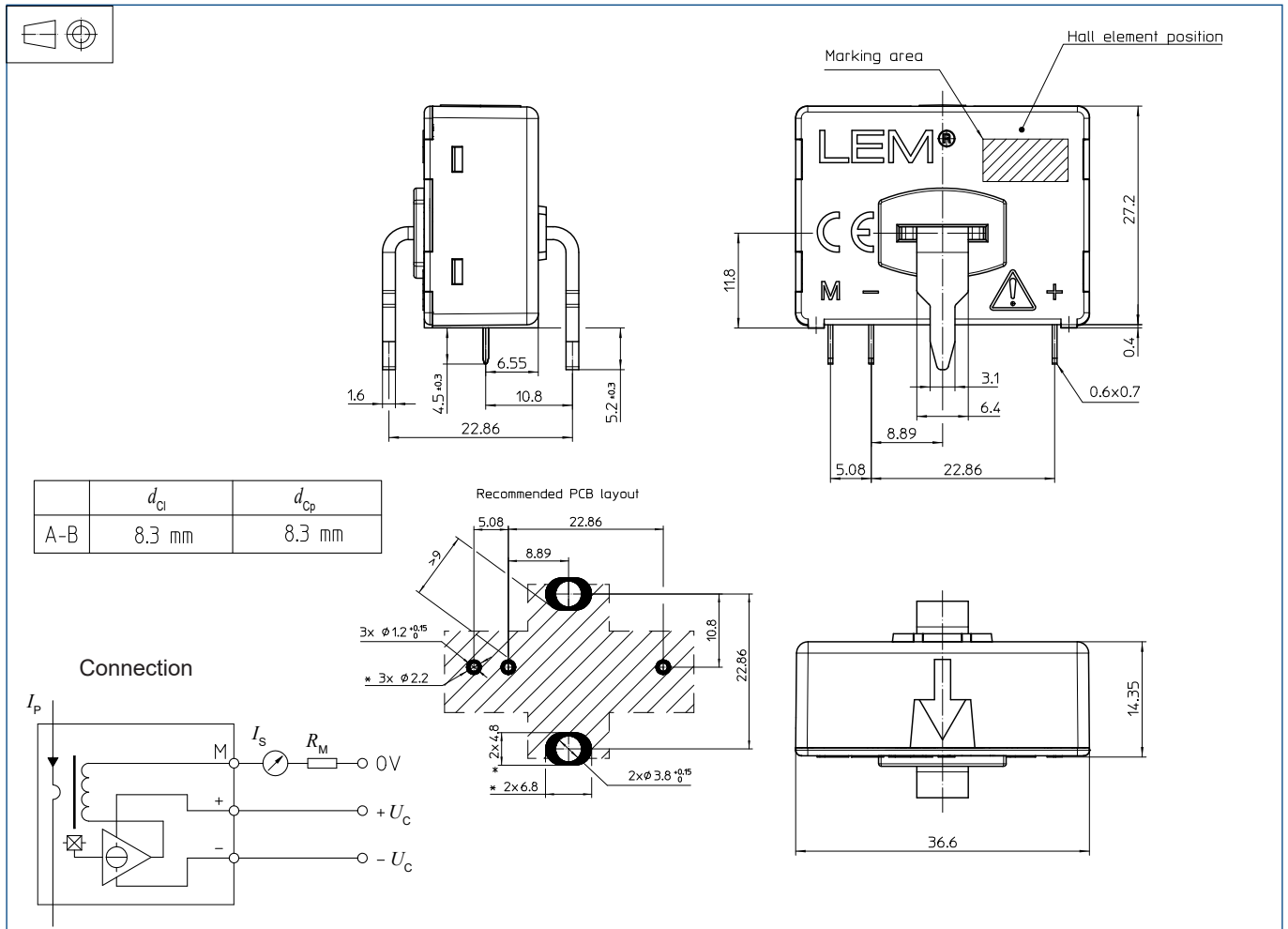

### Mechanical characteristics

- General tolerance  $\pm 0.2$  mm
- Fastening & connection of primary bus bar  $6.4 \times 1.6$  mm
- Recommended PCB hole 3.8 mm
- Fastening & connection of secondary 3 pins  $0.6 \times 0.7$  mm
- Recommended PCB hole  $\phi 1.2$  mm

### Remarks

- $I_s$  is positive when  $I_p$  flows in the direction of the arrow.
- Temperature of the primary conductor should not exceed 90 °C.
- Installation of the transducer must be done unless otherwise specified on the datasheet, according to LEM Transducer Generic Mounting Rules. Please refer to LEM document N°ANE120504 available on our Web site: <https://www.lem.com/en/file/3137/download/>.

单击下面可查看定价，库存，交付和生命周期等信息

[>>LEM\(莱姆\)](#)