

# Current Transducer HASS 50 ... 600-S

For the electronic measurement of currents: DC, AC, pulsed..., with galvanic separation between the primary circuit and the secondary circuit.



All data are given with  $R_L = 10\text{ k}\Omega$

$$I_{PN} = 50 \dots 600\text{ A}$$



## Electrical data

	Primary nominal RMS current	Primary current measuring range	Type	
	$I_{PN}$ (A)	$I_{PM}$ (A)		
	50	$\pm 150$	<b>HASS 50-S</b>	
	100	$\pm 300$	<b>HASS 100-S</b>	
	200	$\pm 600$	<b>HASS 200-S</b>	
	300	$\pm 900$	<b>HASS 300-S</b>	
	400	$\pm 1100$	<b>HASS 400-S</b>	
	500	$\pm 1100$	<b>HASS 500-S</b>	
	600	$\pm 1100$	<b>HASS 600-S</b>	
$S_{Th}$	External detection threshold sensitivity @ $I_{PN}$		0.625	V / $I_{PN}$
$U_{out}$	Analog output voltage @ $I_p$		$U_{OE} \pm (0.625 \cdot I_p / I_{PN})$ V	
$U_{ref}$	Reference voltage <sup>1)</sup>	Output voltage	$2.5 \pm 0.025$	V
		Output impedance	typ. 200	$\Omega$
		Load impedance	$\geq 200$	$\Omega$
$R_L$	Load resistance		$\geq 2$	k $\Omega$
$R_{out}$	Output internal resistance		$< 5$	$\Omega$
$C_L$	Load capacitance ( $\pm 20\%$ )		$= 4.7$	nF
$U_C$	Supply voltage ( $\pm 5\%$ ) <sup>2)</sup>		5	V
$I_C$	Current consumption @ $U_C = 5\text{ V}$		19 (typ) 25 (max)	mA mA

## Accuracy - Dynamic performance data

$\epsilon_{tot}$	Total error <sup>3)</sup> @ $I_{PN}$ , $T_A = 25^\circ\text{C}$	$\leq \pm 1$	%
$\epsilon_L$	Linearity error	$0 \dots I_{PN}$	$\leq \pm 0.5$ %
		$0 \dots I_{PM}$	$\leq \pm 1$ %
$TCU_{OE}$	Temperature coefficient of $U_{OE}$ ( $U_{out} - U_{ref}$ @ $I_p = 0$ )	$\leq \pm 0.1$	mV/K
$TCU_{ref}$	Temperature coefficient of $U_{ref}$	$\leq \pm 190$	ppm/K
$TCS$	Temperature coefficient of $S$	$\leq \pm 250$	ppm/K
$U_{OE}$	Electrical offset voltage @ $I_p = 0$ , $T_A = 25^\circ\text{C}$	$U_{ref} \pm 0.015$	V
$U_{OM}$	Magnetic offset voltage @ $I_p = 0$ after an overload of $I_{PM}$	$< \pm 0.4$	%
$t_{D10}$	Delay time to 10 % of the final output value for $I_{PN}$ step <sup>4)</sup>	$< 3$	$\mu\text{s}$
$t_{D90}$	Delay time to 90 % of the final output value for $I_{PN}$ step	<b>HASS 50-S</b>	$< 4$ $\mu\text{s}$
		<b>others</b>	$< 3.5$ $\mu\text{s}$
$U_{no}$	RMS noise voltage referred to primary (DC .. 20 MHz)	$< 40$	mVpp
$BW$	Frequency bandwidth ( $-3\text{ dB}$ ) <sup>5)</sup>	DC ... 240	kHz

## Features

- Hall effect measuring principle
- Galvanic separation between primary and secondary circuit
- Insulation test voltage 3300 V
- Low power consumption
- Single power supply +5 V
- Fixed offset & sensitivity
- Insulating plastic case recognized according to UL 94-V0.

## Advantages

- Easy installation
- Small size and space saving
- Only one design for wide current ratings range
- High immunity to external interference
- Internal & external reference.

## Applications

- AC variable speed drives and servo motor drives
- Static converters for DC motor drives
- Battery supplied applications
- Uninterruptible Power Supplies (UPS)
- Switched Mode Power Supplies (SMPS)
- Power supplies for welding applications.

## Application domain

- Industrial.

## Current Transducer HASS 50 ... 600-S

### General data

$T_A$	Ambient operating temperature	-40 ... +105 °C	
$T_{Ast}$	Ambient storage temperature	-40 ... +105 °C	
$m$	Mass	55	g
	Standard	EN 50178: 1997	

- Notes: <sup>1)</sup> It is possible to overdrive  $U_{ref}$  with an external reference voltage between 0.5 - 2.65 V providing its ability to sink or source approximately 5 mA
- <sup>2)</sup> Maximum supply voltage (not operating) < 6.5 V
- <sup>3)</sup> Excluding offset and magnetic offset voltage
- <sup>4)</sup> For a  $di/dt = 100 \text{ A}/\mu\text{s}$
- <sup>5)</sup> Small signal only to avoid excessive heatings of the magnetic core.

### Insulation coordination

$U_d$	RMS voltage for AC insulation test, 50 Hz, 1 min	3.3	kV
$U_t$	Partial discharge RMS test voltage @ 10 pC	> 1	kV
$U_{Ni}$	Impulse withstand voltage 1.2/50 $\mu\text{s}$	6	kV
		Min	
$d_{Cp}$	Creepage distance	> 5.5	mm
$d_{Cl}$	Clearance distance	> 5.5	mm
$CTI$	Comparative Tracking Index (group I)	> 600	

### Applications examples

According to EN 50178 and IEC 61010-1 standards and following conditions:

- Over voltage category OV 3
- Pollution degree PD2
- Non-uniform field

	EN 50178	IEC 61010-1
$d_{Cp}, d_{Cl}, U_{Ni}$	Rated insulation voltage	Nominal voltage
Basic insulation	600 V	600 V
Reinforced insulation	300 V	150 V

### Safety

This transducer must be used in limited-energy secondary circuits according to IEC 61010-1.



This transducer must be used in electric/electronic equipment with respect to applicable standards and safety requirements in accordance with the manufacturer's operating instructions.



Caution, risk of electrical shock

When operating the transducer, certain parts of the module can carry hazardous voltage (eg. primary busbar, power supply). Ignoring this warning can lead to injury and/or cause serious damage.

This transducer is a build-in device, whose conducting parts must be inaccessible after installation. A protective housing or additional shield could be used.

Main supply must be able to be disconnected.

## Dimensions HASS 50 ... 600-S (in mm)

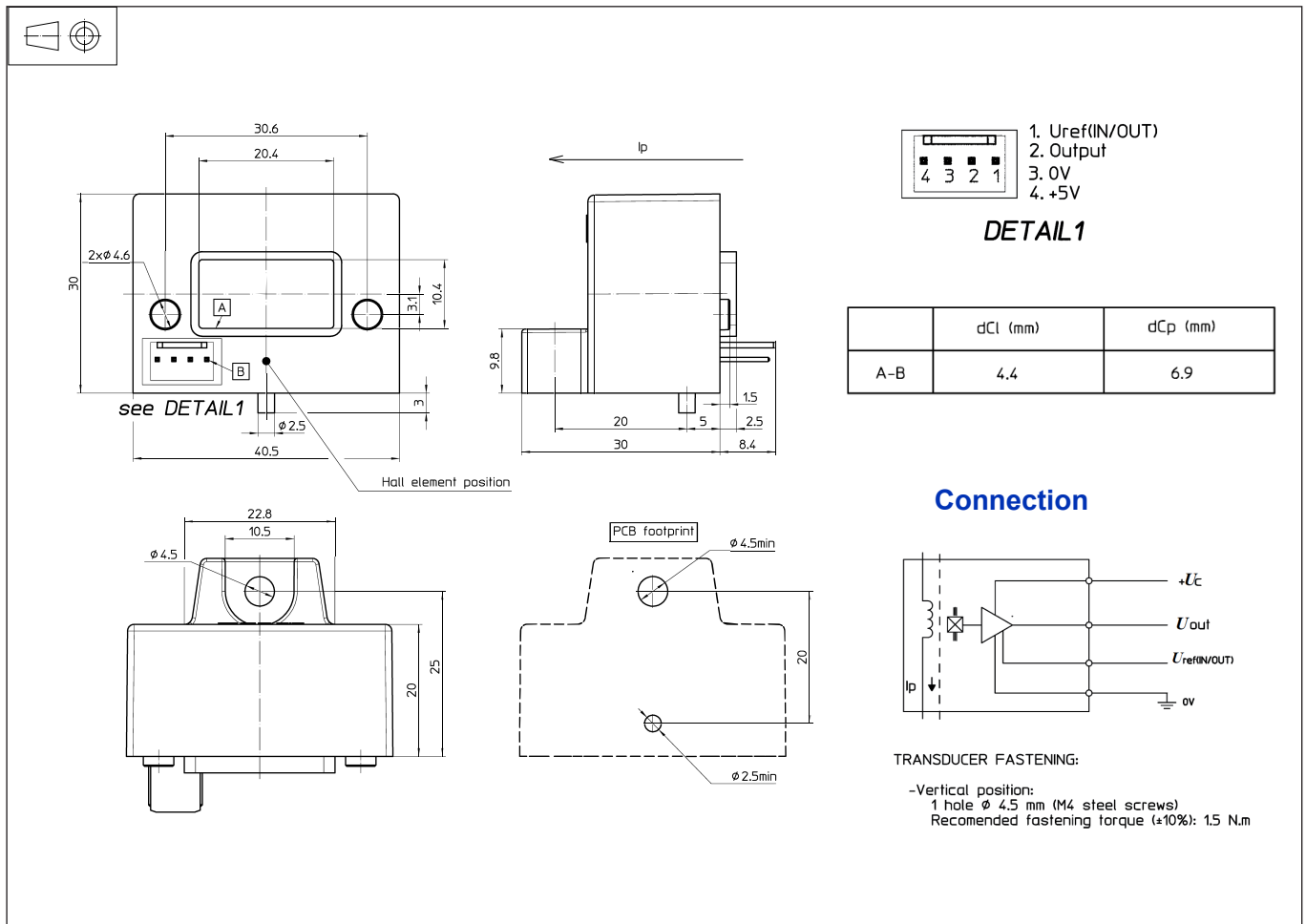

### Required connection circuit

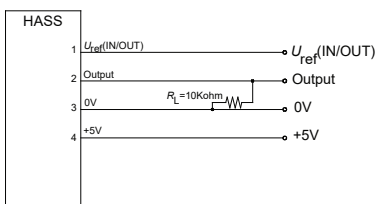

### Operation principle

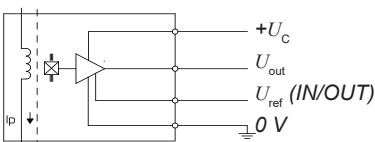

### Mechanical characteristics

- General tolerance  $\pm 0.5$  mm
- Aperture for primary conductor  $20.4 \times 10.4 \times 0.5$  mm
- Transducer fastening M4
- Recommended fastening torque  $< 1.5$  N·m
- Connection of secondary Molex 5045-04A

### Remarks

- $I_s$  is positive when  $I_p$  flows in the direction of the arrow.
- Temperature of the primary conductor should not exceed  $120$  °C.
- This is a standard model. For different versions (supply voltages, turns ratios, unidirectional measurements...), please contact us.
- Installation of the transducer must be done unless otherwise specified on the datasheet, according to LEM Transducer Generic Mounting Rules. Please refer to LEM document N°ANE120504 available on our Web site: <https://www.lem.com/en/file/3137/download/>.

单击下面可查看定价，库存，交付和生命周期等信息

[>>LEM\(莱姆\)](#)