

Current Transducer LA 150-TP

For the electronic measurement of currents: DC, AC, pulsed..., with galvanic separation between the primary circuit and the secondary circuit.

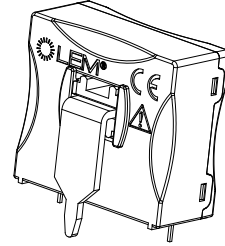

$$I_{PN} = 150 \text{ A}$$



Electrical data

I_{PN}	Primary nominal rms current	150	A
I_{PM}	Primary current, measuring range	0 .. ± 212	A
R_M	Measuring resistance	$R_{M \min}$ $R_{M \max}$	
		with ± 12 V	@ ± 150 A _{max} 0 40 Ω @ ± 212 A _{max} 0 3 Ω
	With ± 15 V	@ ± 150 A _{max} 0 78 Ω @ ± 212 A _{max} 0 30 Ω	
		I_{SN}	Secondary nominal rms current
K_N	Conversion ratio	1 : 2000	
U_C	Supply voltage	± 12 .. 15	V
I_C	Current consumption	10 (@ ± 15 V) + I_S	mA

Accuracy - Dynamic performance data

X	Accuracy @ I_{PN} , $T_A = 25^\circ\text{C}$	± 0.5	%
ϵ_L	Linearity error	< 0.1	%
I_{OE}	Electrical offset current @ $I_P = 0$, $T_A = 25^\circ\text{C}$	Typ	± 0.10 mA
		Max	± 0.10 mA
I_{OM}	Magnetic offset current @ $I_P = 0$ and specified R_M , after an overload of $3 \times I_{PN}$	± 0.25	mA
I_{OT}	Temperature variation of I_O - 40 °C .. + 85 °C	± 0.15	± 0.30 mA
t_{ra}	Reaction time	< 300	ns
t_r	Step response time ¹⁾ to 90 % of I_{PN}	< 500	ns
di/dt	di/dt accurately followed	> 100	A/μs
BW	Frequency bandwidth (- 1 dB)	DC .. 150	kHz

General data

T_A	Ambient operating temperature	- 40 .. + 85	°C
T_S	Ambient storage temperature	- 40 .. + 90	°C
R_S	Resistance of secondary winding @ $T_A = 25^\circ\text{C}$	64 ± 2	Ω
m	Mass	< 35	g
	Standards	EN 50178: 1997 UL 508: 2010	

Note: ¹⁾ with di/dt of 100 A/μs.

Features

- Closed loop (compensated) current transducer using the Hall effect
- Insulating plastic case recognized according to UL 94-V0.

Advantages

- Excellent accuracy
- Very good linearity
- Low temperature drift
- Optimized response time
- Wide frequency bandwidth
- No insertion losses
- High immunity to external interference
- Current overload capability.

Applications

- AC variable speed drives and servo motor drives
- Static converters for DC motor drives
- Battery supplied applications
- Uninterruptible Power Supplies (UPS)
- Switched Mode Power Supplies (SMPS)
- Power supplies for welding applications.

Application domain

- Industrial.

Current Transducer LA 150-TP

Insulation coordination

U_d	Rms voltage for AC insulation test, 50 Hz, 1 min	4.3	kV
\hat{U}_w	Impulse withstand voltage 1.2/50 μ s	8	kV
U_e	Partial discharge extinction rms voltage @ 10 pC	1.3	kV
		Min	
d_{cp}	Creepage distance	8	mm
d_{cl}	Clearance	8	mm
CTI	Comparative Tracking Index (group I)	600	

Applications examples

According to EN 50178 and IEC 61010-1 standards and following conditions:

- Over voltage category OV 3
- Pollution degree PD2
- Non-uniform field

	EN 50178	IEC 61010-1
$d_{cp}, d_{cl}, \hat{U}_w$	Rated insulation voltage	Nominal voltage
Basic insulation	1000 V	1000 V
Reinforced insulation	600 V	400 V

Safety

This transducer must be used in limited-energy secondary circuits according to IEC 61010-1.



This transducer must be used in electric/electronic equipment with respect to applicable standards and safety requirements in accordance with the manufacturer's operating instructions.



Caution, risk of electrical shock

When operating the transducer, certain parts of the module can carry hazardous voltage (eg. primary busbar, power supply). Ignoring this warning can lead to injury and/or cause serious damage.

This transducer is a build-in device, whose conducting parts must be inaccessible after installation. A protective housing or additional shield could be used.

Main supply must be able to be disconnected.

Dimensions LA 150-TP (in mm)

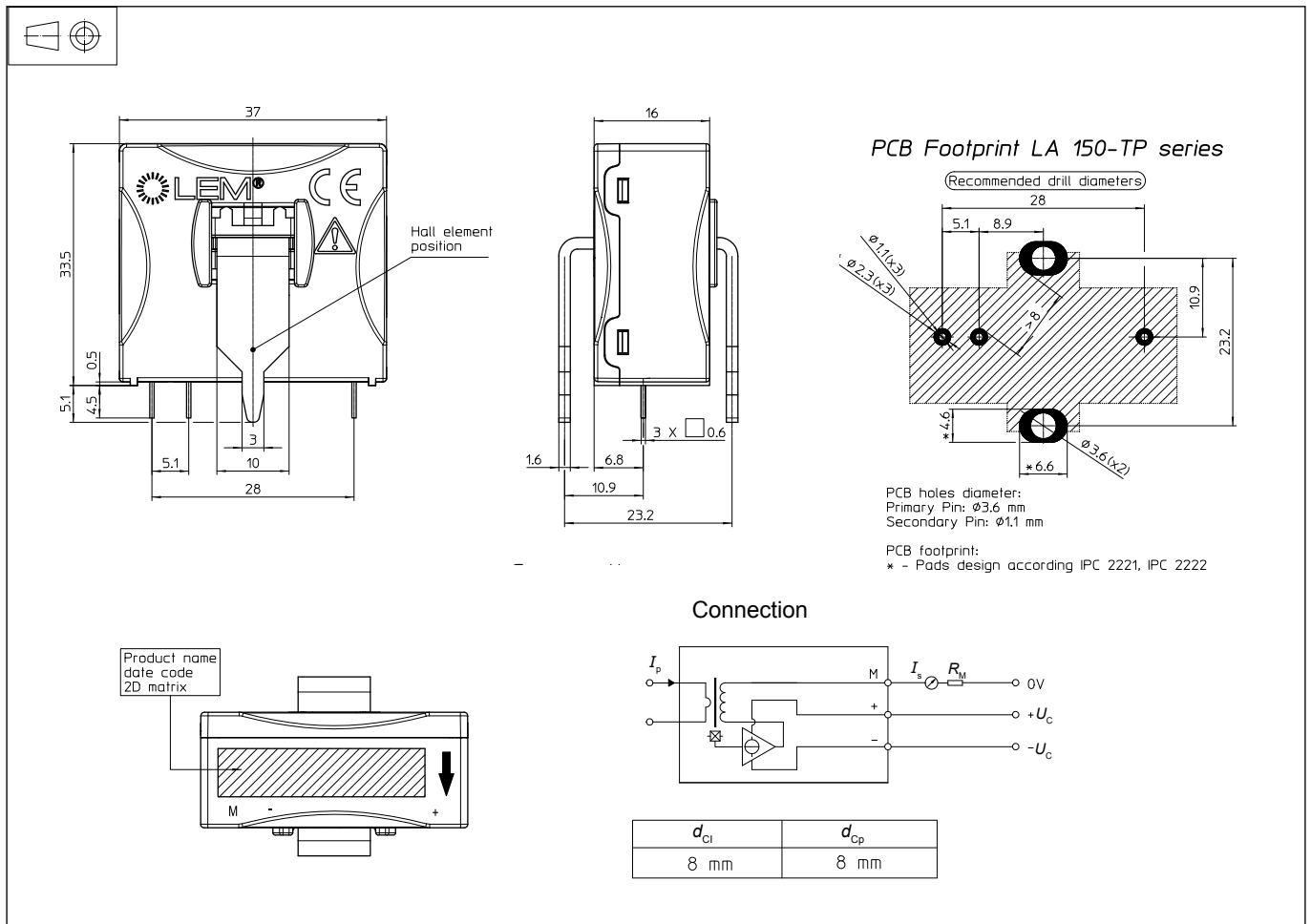

Mechanical characteristics

- General tolerance ± 0.5 mm
- Fastening & connection of primary
Recommended PCB hole $\varnothing 3.6$ mm
- Fastening & connection of secondary
Recommended PCB hole $\varnothing 1.1$ mm

Remarks

- I_s is positive when I_p flows in the direction of the arrow.
- Temperature of the primary conductor should not exceed 100°C .
- Dynamic performances (di/dt and response time) are best with a single bar completely filling the primary hole.
- Installation of the transducer must be done unless otherwise specified on the datasheet, according to LEM Transducer Generic Mounting Rules. Please refer to LEM document N°ANE120504 available on our Web site: [Products/Product Documentation](#).
- This is a standard model. For different versions (supply voltages, turns ratios, unidirectional measurements...), please contact us.

单击下面可查看定价，库存，交付和生命周期等信息

[>>LEM\(莱姆\)](#)