

Current Transducer LF 305-S/SP10

For the electronic measurement of currents: DC, AC, pulsed..., with galvanic separation between the primary circuit and the secondary circuit.

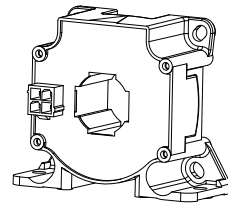

$I_{PN} = 300 \text{ A}$



Electrical data

I_{PN}	Primary nominal RMS current	300	A			
I_{PM}	Primary current, measuring range	0 ... ± 500	A			
R_M	Measuring resistance	$T_A = 70 \text{ }^\circ\text{C}$		$T_A = 85 \text{ }^\circ\text{C}$		
		$R_{M \min}$	$R_{M \max}$	$R_{M \min}$	$R_{M \max}$	Ω
	with $\pm 12 \text{ V}$	@ $\pm 300 \text{ A}_{\max}$	0	39	0	37
		@ $\pm 500 \text{ A}_{\max}$	0	10	0	8
	with $\pm 15 \text{ V}$	@ $\pm 300 \text{ A}_{\max}$	0	58	0	56
		@ $\pm 500 \text{ A}_{\max}$	0	21	0	19
with $\pm 20 \text{ V}$	@ $\pm 300 \text{ A}_{\max}$	0	90	0	88	
	@ $\pm 500 \text{ A}_{\max}$	0	40	0	38	
I_{SN}	Secondary nominal RMS current	150	mA			
N_p/N_s	Turns ratio	1 : 2000				
U_C	Supply voltage ($\pm 5 \%$)	$\pm 12 \dots 20$	V			
I_C	Current consumption	16 (@ $\pm 20 \text{ V}$) + I_S	mA			

Accuracy - Dynamic performance data

ϵ_{tot}	Total error @ $I_{PN}, T_A = 25 \text{ }^\circ\text{C}$	± 0.47	%
ϵ_L	Linearity error	< 0.1	%
I_O	Offset current @ $I_p = 0, T_A = 25 \text{ }^\circ\text{C}$	Typ	Max
			± 0.2
I_{OM}	Magnetic offset current ¹⁾ @ $I_p = 0$ and specified R_M after an overload of $3 \times I_{PN}$		± 0.2
			mA
I_{OT}	Temperature variation of I_O	-10 $^\circ\text{C}$... +70 $^\circ\text{C}$	± 0.1 ± 0.30
		-40 $^\circ\text{C}$... +85 $^\circ\text{C}$	± 0.2 ± 0.70
t_{D10}	Delay time to 10 % of the final output value for I_{PN} step < 500		ns
t_{D90}	Delay time to 90 % of the final output value for I_{PN} step ²⁾ < 1		μs
BW	Frequency bandwidth (-3 dB)	DC ... 100	kHz

General data

T_A	Ambient operating temperature	-40 ... +85	$^\circ\text{C}$
T_{Ast}	Ambient storage temperature	-40 ... +85	$^\circ\text{C}$
R_S	Resistance of secondary winding @ $T_A = 70 \text{ }^\circ\text{C}$	30	Ω
		@ $T_A = 85 \text{ }^\circ\text{C}$	32
m	Mass Standards	95	g
		EN 50178:1997 ³⁾	
		EN 50155: 2017 ⁴⁾	
		UL 508: 2013	
		EN 50121-3-2: 2016	

Notes: ¹⁾ The result of the coercive force of the magnetic circuit
²⁾ For a $di/dt = 100 \text{ A}/\mu\text{s}$
³⁾ Excepted test according to IEC 61000-4-5
⁴⁾ Additional information available on request.

Features

- Closed loop (compensated) current transducer using the Hall effect
- Insulating plastic case recognized according to UL 94-V0.

Special features

- $T_A = -40 \dots +85 \text{ }^\circ\text{C}$
- Connection of secondary on Molex MiniFit Jr 5566 with gold-plated pins connector.

Advantages

- Excellent accuracy
- Very good linearity
- Low temperature drift
- Optimized response time
- Wide frequency bandwidth
- No insertion losses
- High immunity to external interference
- Current overload capability.

Applications

- AC variable speed drives and servo motor drives
- Static converters for DC motor drives
- Battery supplied applications
- Uninterruptible Power Supplies (UPS)
- Switched Mode Power Supplies (SMPS)
- Power supplies for welding applications
- Single or three phase inverters
- Propulsion and braking choppers
- Propulsion converters
- Auxiliary converters
- Battery chargers.

Application domains

- Industrial
- Railway (fixed installations and onboard).

Current Transducer LF 305-S/SP10

Insulation coordination

U_d	RMS voltage for AC insulation test, 50/60 Hz, 1 min	3	kV
U_{Ni}	Impulse withstand voltage 1.2/50 μ s	9.5	kV
		Min	
d_{Cp}	Creepage distance	22	mm
d_{Cl}	Clearance	10.5	mm
CTI	Comparative tracking index (group IIIa)	175	

Applications examples

According to EN 50178 and IEC 61010-1 standards and following conditions:

- Over voltage category OV 3
- Pollution degree PD2
- Non-uniform field

	EN 50178	IEC 61010-1
d_{Cp}, d_{Cl}, U_{Ni}	Rated insulation voltage	Nominal voltage
Basic insulation	1000 V	2000 V
Reinforced insulation	600 V	600 V

Safety

This transducer must be used in limited-energy secondary circuits according to IEC 61010-1.



This transducer must be used in electric/electronic equipment with respect to applicable standards and safety requirements in accordance with the manufacturer's operating instructions.



Caution, risk of electrical shock

When operating the transducer, certain parts of the module can carry hazardous voltage (eg. primary busbar, power supply).

Ignoring this warning can lead to injury and/or cause serious damage.

This transducer is a build-in device, whose conducting parts must be inaccessible after installation.

A protective housing or additional shield could be used.

Main supply must be able to be disconnected.

Dimensions LF 305-S/SP10 (in mm)

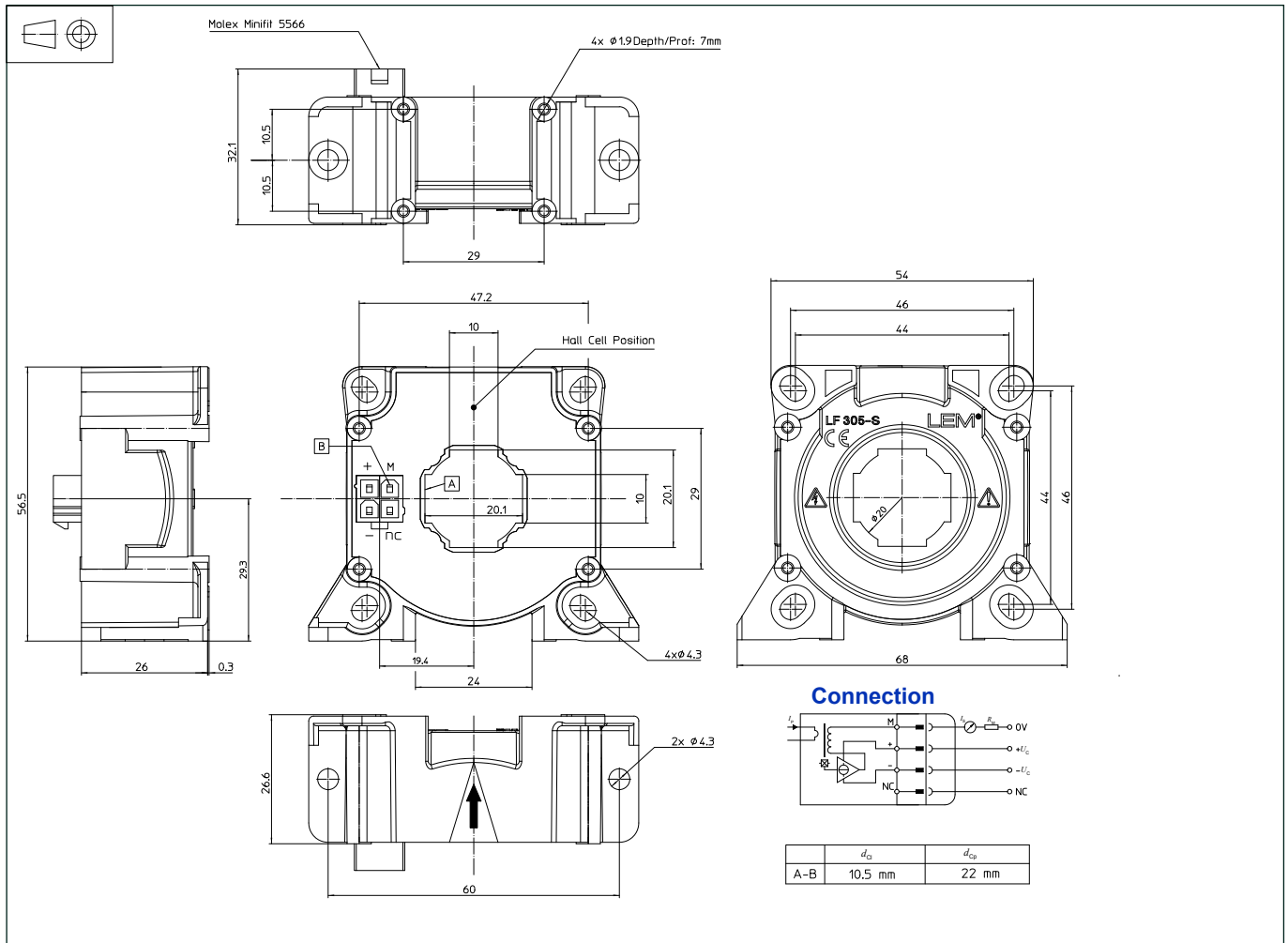

Mechanical characteristics

- General tolerance ± 0.5 mm
- Transducer fastening
 - Vertical position
 - 2 holes $\varnothing 4.3$ mm
 - 2 M4 steel screws
 - Recommended fastening torque 3.2 N·m
 - or
 - 4 holes $\varnothing 1.9$ mm, depth: 7 mm
 - 4 PTKA 25 screws length: 6 mm
 - Recommended fastening torque 0.7 N·m
- Transducer fastening
 - Horizontal position
 - 4 holes $\varnothing 4.3$ mm
 - 2 M4 steel screws
 - Recommended fastening torque 3.2 N·m
 - or
 - 4 holes $\varnothing 1.9$ mm
 - 4 PTKA 25 screws, length: 10 mm
 - Recommended fastening torque 0.75 N·m
- Primary through-hole $\varnothing 20$ mm
- Connection of secondary On Molex MiniFit Jr 5566 gold-plated pins connector

Remarks

- I_s is positive when I_p flows in the direction of the arrow.
- Temperature of the primary conductor should not exceed 100 °C.
- Installation of the transducer must be done unless otherwise specified on the datasheet, according to LEM Transducer Generic Mounting Rules. Please refer to LEM document N°ANE120504 available on our Web site: <https://www.lem.com/en/file/3137/download/>.
- Dynamic performances (di/dt and delay time) are best with a single bar completely filling the primary hole.

单击下面可查看定价，库存，交付和生命周期等信息

[>>LEM\(莱姆\)](#)