

AUTOMOTIVE CURRENT TRANSDUCER OPEN LOOP TECHNOLOGY

HAH2DR 500-S00



Introduction

The HAH2DR-S00 family is a dual-phase transducer for DC, AC, or pulsed currents measurement in high power and low voltage automotive applications. It offers a galvanic separation between the primary circuit (high power) and the secondary circuit (electronic circuit).

The HAH2DR-S00 family gives you a choice of having different current measuring ranges in the same housing (from ± 100 up to ± 500 A).

Features

- Open Loop transducer using the Hall effect sensor
- Low voltage application
- Unipolar +5 V DC power supply
- Primary current measuring range up to ± 500 A
- Maximum RMS primary admissible current: limited by the busbar, the magnetic core or ASIC $T < +150$ °C
- Operating temperature range: -40 °C $< T < +125$ °C
- Output voltage: fully ratio-metric (in sensitivity and offset).

Special feature

- Dual-phase transducer.

Advantages

- Excellent accuracy
- Very good linearity
- Very low thermal offset drift
- Very low thermal sensitivity drift
- Wide frequency bandwidth
- No insertion losses
- Very fast response time.

Automotive applications

- Starter Generators
- Inverters
- HEV applications
- EV applications
- DC / DC converters.

Principle of HAH2DR-S00 family

The open loop transducers uses a Hall effect integrated circuit. The magnetic flux density B , contributing to the rise of the Hall voltage, is generated by the primary current I_p to be measured.

The current to be measured I_p is supplied by a current source i.e. battery or generator (Figure 1).

Within the linear region of the hysteresis cycle, B is proportional to:

$$B(I_p) = a \times I_p$$

The Hall voltage is thus expressed by:

$$U_H = (c_H / d) \times I_H \times a \times I_p$$

Except for I_p , all terms of this equation are constant. Therefore:

$$U_H = b \times I_p$$

a constant

b constant

c_H Hall coefficient

d thickness of the Hall plate

I_H current across the Hall plates

The measurement signal U_H amplified to supply the user output voltage or current.

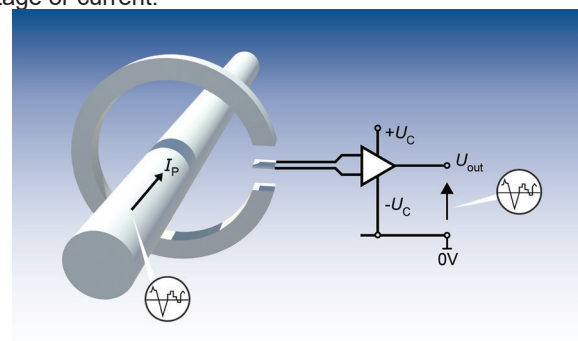
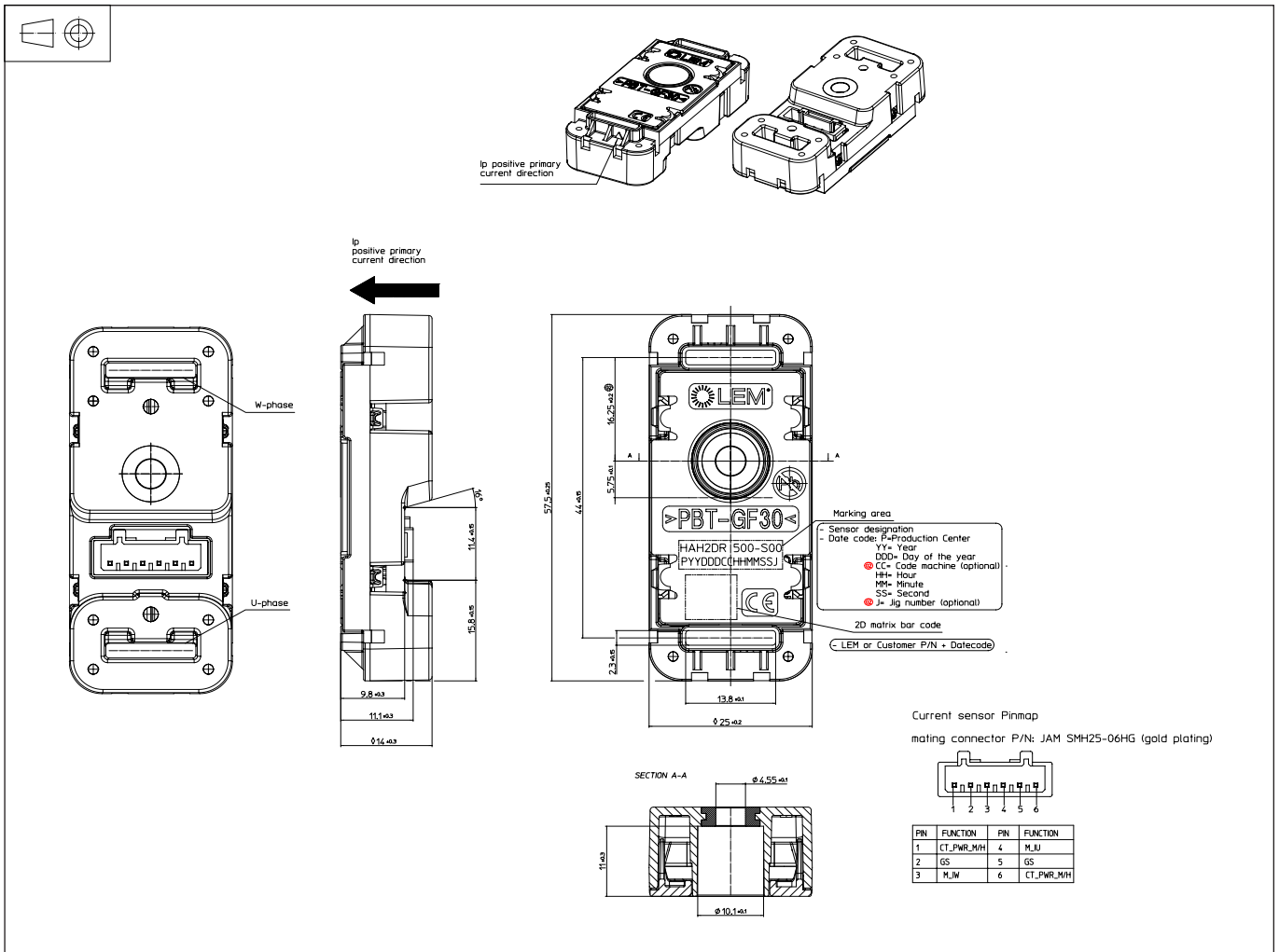

Fig. 1: Principle of the open loop transducer.

Dimensions (in mm)



Mechanical characteristics

- Plastic case >PBT-GF30< (Natural)
- Magnetic core FeSi wound core
- Pins Copper alloy gold plated
- Mass 25 g ± 5 %

Mounting recommendation

- Mating connector P/N JAM SMH25.06 HG (gold plating)
- Assembly torque 1.8 N·m
- The clamping force must be applied to the compression limiter, washer recommended.

$R_L > 10 \text{ k}\Omega$ optional resistor for signal line diagnostic
 $C_L < 2.2 \text{ nF}$ EMC protection

RC: low pass filter (optional)
 Capacitor U_{ref} / Gnd 1 nF
 Capacitor U_C / Gnd 47 nF

Remark

- $U_{out} > U_o$ when I_p flows in the positive direction (see arrow on drawing).

System architecture (example)

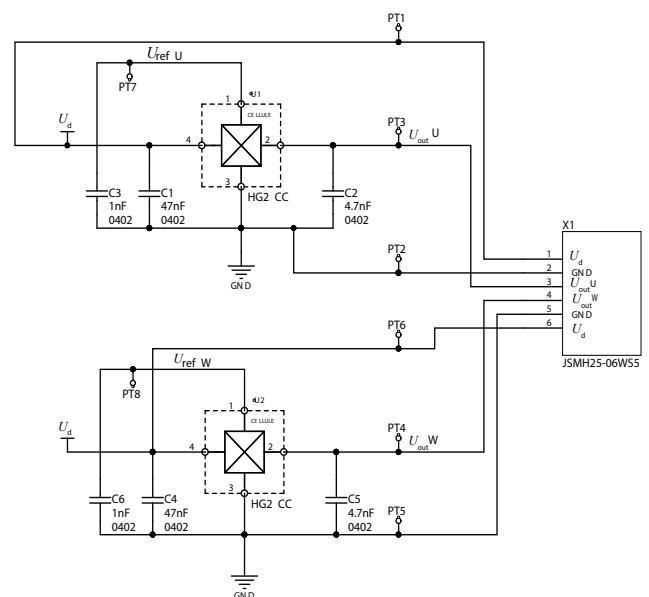

Absolute ratings (not operating)

Parameter	Symbol	Unit	Specification			Conditions
			Min	Typical	Max	
Maximum supply voltage	U_C	V			8	Continuous, not operating
					6.5	Exceeding this voltage may temporarily reconfigure the circuit until the next power-on
Output voltage low ¹⁾	U_{outL}				0.2	@ $U_C = 5\text{ V}$, $T_A = 25\text{ °C}$
Output voltage high ¹⁾	U_{outH}		4.8			
Ambient storage temperature	T_S	°C	-40		125	
Electrostatic discharge voltage (HBM)	$U_{ESD\text{HBM}}$	kV			2	JESD22-A114-B class 2
Rms voltage for AC insulation test	U_d	kV			2.5	50 Hz, 1 min, IEC 60664 part1 ($I < 0.1\text{ mA}$)
Creepage distance	d_{cp}	mm	3.94			
Clearance	d_{cl}	mm	3.94			
Comparative tracking index	CTI	-	200			
Maximum reverse current ³⁾	I_R	mA	-80		80	
Insulation resistance	R_{INS}	MΩ	500			500 V DC, ISO 16750-2
Primary nominal peak current	\hat{I}_{PN}	A			²⁾	

Operating characteristics in nominal range (I_{PN})

Parameter	Symbol	Unit	Specification			Conditions
			Min	Typical	Max	
Electrical Data						
Primary current, measuring range	I_{PM}	A	-500		500	
Primary nominal DC or RMS current	I_{PN}	A	-500		500	
Supply voltage ¹⁾	U_C	V	4.75	5	5.25	
Ambient operating temperature	T_A	°C	-40		125	
Capacitive loading	C_L	nF	4	4.7	6	
Output voltage (Analog) ¹⁾	U_{out}	V	$U_{out} = (U_C/5) \times (U_o + S \times I_p)$			@ U_C
Offset voltage	U_o	V		2.5		@ $U_C = 5\text{ V}$
Sensitivity ¹⁾	S	mV/A		4		@ $U_C = 5\text{ V}$
Current consumption (for 2 phases)	I_C	mA		30	30	@ $U_C = 5\text{ V}$, @ $-40\text{ °C} < T_A < 125\text{ °C}$
Load resistance	R_L	KΩ	10			
Output internal resistance	R_{out}	Ω			10	DC to 1 KHz
Performance Data						
Ratiometricity error	ε_r	%		±0.6		
Sensitivity error	ε_s	%		±0.5		@ $T_A = 25\text{ °C}$, @ $U_C = 5\text{ V}$
				±1		@ $T_A = 25\text{ °C}$, After T Cycles, @ $U_C = 5\text{ V}$
Electrical offset voltage	U_{OE}	mV		±6		@ $T_A = 25\text{ °C}$, @ $U_C = 5\text{ V}$
Magnetic offset voltage	U_{OM}	mV		±3		@ $T_A = 25\text{ °C}$, @ $U_C = 5\text{ V}$
Average temperature coefficient of U_{OE}	TCU_{OEAV}	mV/°C		±0.05		@ $-40\text{ °C} < T_A < 125\text{ °C}$
Average temperature coefficient of S	TCS_{AV}	%/°C		±0.02		@ $-40\text{ °C} < T_A < 125\text{ °C}$
Linearity error	ε_L	% I_{PM}	-1		1	@ $U_C = 5\text{ V}$, @ $T_A = 25\text{ °C}$, @ $I_p = I_{PM}$
Delay time to 90 % of I_{PN}	t_{D90}	μs			10	$di/dr = 100\text{ A}/\mu\text{s}$
Frequency bandwidth ²⁾	BW	kHz	30			@ -3 dB
Peak to peak noise voltage	$U_{no,pp}$	mV			15	@ DC to 1 MHz
Phase shift	$\Delta\phi$	°	-45			@ 20 kHz

Notes: ¹⁾ The output voltage U_{out} is fully ratiometric. The offset and sensitivity are dependent on the supply voltage U_C relative to the following formula:

$$I_p = \left(\frac{5}{U_C} \times U_{out} - U_o \right) \times \frac{1}{S} \text{ with } S \text{ in (V/A)}$$

²⁾ Primary current frequencies must be limited in order to avoid excessive heating of the busbar, magnetic core and the ASIC (see feature paragraph in page 1/7).

³⁾ Transducer is not protected against reverse polarity.

Accuracy

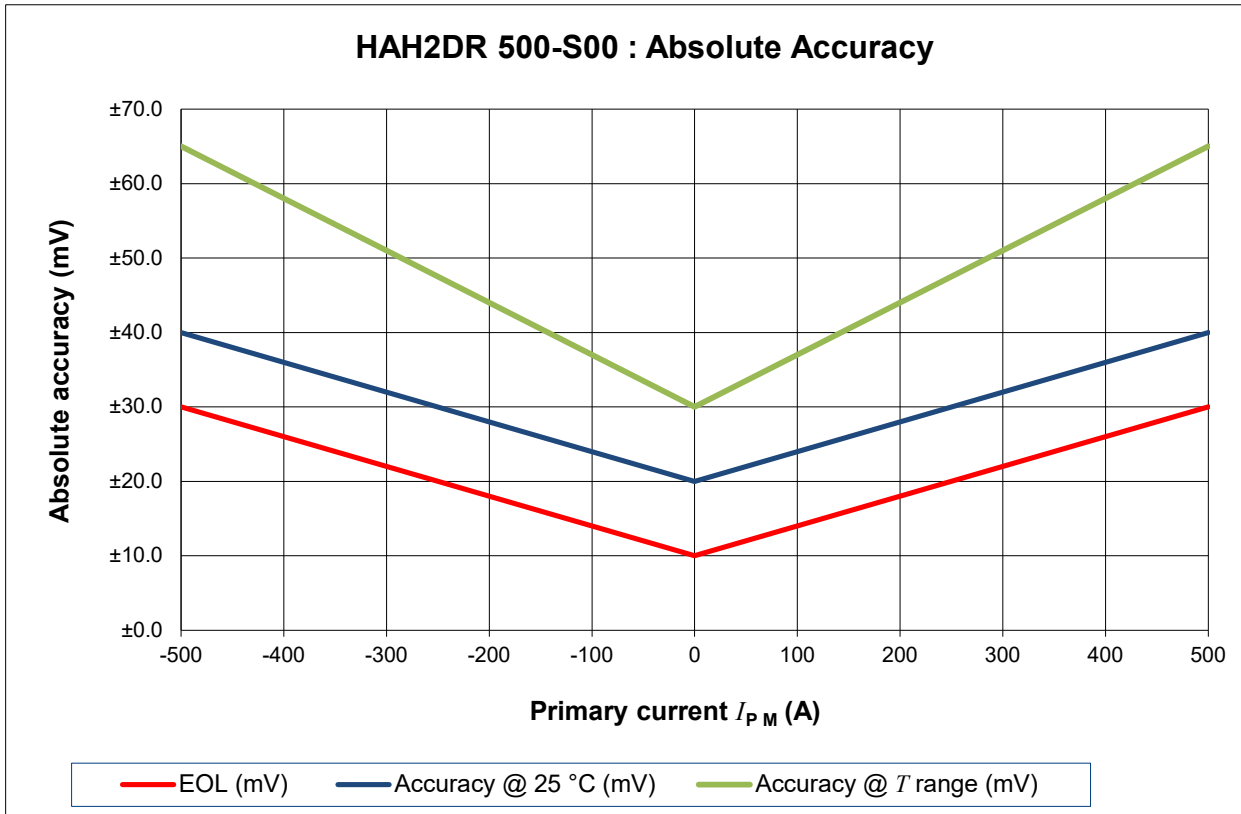

EOL data guarantee by End Of Line calibration but not for the field return.

I_p (A)	EOL (mV)	Accuracy @ 25 °C (mV)	Accuracy @ T range (mV)
-500	±30	±40	±65
0	±10	±20	±30
500	±30	±40	±65

PERFORMANCES PARAMETERS DEFINITIONS

Primary current definition:

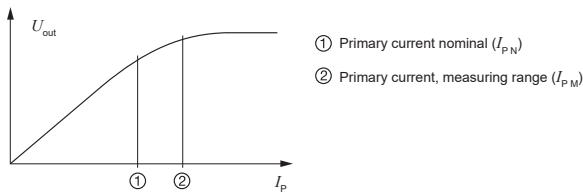

Definition of typical, minimum and maximum values:

Minimum and maximum values for specified limiting and safety conditions have to be understood as such as values shown in "typical" graphs. On the other hand, measured values are part of a statistical distribution that can be specified by an interval with upper and lower limits and a probability for measured values to lie within this interval. Unless otherwise stated (e.g. "100 % tested"), the LEM definition for such intervals designated with "min" and "max" is that the probability for values of samples to lie in this interval is 99.73 %. For a normal (Gaussian) distribution, this corresponds to an interval between -3 sigma and +3 sigma. If "typical" values are not obviously mean or average values, those values are defined to delimit intervals with a probability of 68.27 %, corresponding to an interval between -sigma and +sigma for a normal distribution. Typical, minimum and maximum values are determined during the initial characterization of a product.

Output noise voltage:

The output voltage noise is the result of the noise floor of the Hall elements and the linear amplifier.

Magnetic offset:

The magnetic offset is the consequence of an any current on the primary side. It's defined after a stated excursion of primary current.

Linearity:

The maximum positive or negative discrepancy with a reference straight line $U_{out} = f(I_p)$.
Unit: linearity (%) expressed with full scale of I_{pN} .

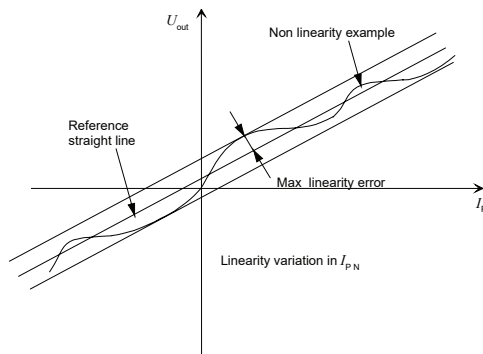

Delay time t_{D90} :

The time between the primary current signal (I_{pN}) and the output signal reach at 90 % of its final value.

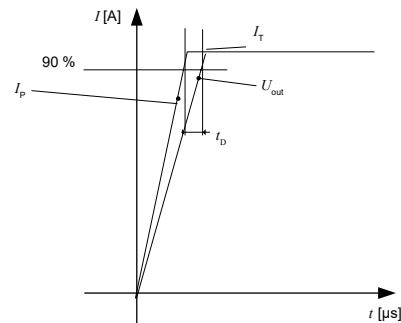

Sensitivity:

The transducer's sensitivity S is the slope of the straight line $U_{out} = f(I_p)$, it must establish the relation:

$$U_{out}(I_p) = U_c/5 (S \times I_p + U_o)$$

Offset with temperature:

The error of the offset in the operating temperature is the variation of the offset in the temperature considered with the initial offset at 25 °C.

The offset variation I_{OT} is a maximum variation the offset in the temperature range:

$$I_{OT} = I_{OE \max} - I_{OE \min}$$

The offset drift $TCI_{OE \text{ AV}}$ is the I_{OT} value divided by the temperature range.

Sensitivity with temperature:

The error of the sensitivity in the operating temperature is the relative variation of sensitivity with the temperature considered with the initial offset at 25 °C.

The sensitivity variation S_T is the maximum variation (in ppm or %) of the sensitivity in the temperature range:
 $S_T = (\text{Sensitivity max} - \text{Sensitivity min}) / \text{Sensitivity at } 25 \text{ }^\circ\text{C}$.

The sensitivity drift TCS_{AV} is the S_T value divided by the temperature range. Deeper and detailed info available is our LEM technical sales offices (www.lem.com).

Offset voltage @ $I_p = 0 \text{ A}$:

The offset voltage is the output voltage when the primary current is zero. The ideal value of U_o is $U_c/2$. So, the difference of $U_o - U_c/2$ is called the total offset voltage error. This offset error can be attributed to the electrical offset (due to the resolution of the ASIC quiescent voltage trimming), the magnetic offset, the thermal drift and the thermal hysteresis. Deeper and detailed info available is our LEM technical sales offices (www.lem.com).

Environmental test specifications:

Refer to LEM GROUP test plan laboratory CO.11.11.515.0 with "Tracking_Test Plan_Auto" sheet.

Environmental test specifications:

Refer to LEM GROUP test plan laboratory CO.11.11.515.0 with "Tracking_Test Plan_Auto" sheet.

Name	Standard	Conditions
ELECTRICAL TESTS		
Phase shift	LEM Procedure	100 Hz to 10 kHz at 20 A peak
Noise measurement	LEM Procedure	Sweep from DC to 1 MHz
Delay time di/dr	LEM Procedure	100 A/ μ s I pulse = 300 A
dv/dt	LEM Procedure	5 kV/ μ s $U = 1000$ V
RMS voltage for AC insulation test	IEC 60664 part 1	2.5 kV VAC / 1 min / 50 Hz ($I < 0.1$ mA)
Insulation resistance test	ISO 16750-2 (2010)	500 V DC, time = 60 s $R_{INS} > = 500$ M Ω Minimum
ENVIRONMENTAL TESTS		
High T °C, High Humidity, Electrical connection	ES90000-4 § 6.4	1000 h + 85 °C / 85 % RH $U_C = 5$ V DC, $I_p = 0$ A
Thermal Cycle Test (Simplified profile)	IEC 60068-2-14, Test Nb	1000 cycles (2000 h), Slope 10 °C / min -40 °C (30') / +25 °C (15') / +105 °C (30') U_C not connected, $I_p = 0$ A
Thermal Shock	IEC 60068-2-14 (2009) Test Na Test Na	1000 cycles (1000 h), 30 min "-40 °C" // 80 min "+85 °C" U_C not connected, $I_p = 0$ A
Dew Condensation		$I_p = 0$ A all test. $U_C = 0$ for 2 h then $U_C = 5$ V for end of test 2 h "-5 °C / 0 % HR" // 10 min "35 °C / 85 % HR"
High T °C Storage		125 °C for 1000 h U_C not connected, $I_p = 0$ A
Low T °C Storage		-40 °C for 1000 h U_C not connected, $I_p = 0$ A
Mechanical Shock	IEC 60068-2-27 (2008) Test Ea	50 g / 5 ms Half Sine @ 25 °C 10 shocks of each direction U_C not connected, $I_p = 0$ A
Vibration test		10 Hz -> 500 Hz -> 10 Hz sweep 15 min, 2 h / axes @ 10 G and 25 °C Monitoring U_{out} during vibration. $U_C = 5$ V, $I_p = 0$ A
EMC TESTS ES96200 (11.2011)		
Radiated Emission Absorber Lined Shielded Enclosure (ALSE)	ES96200-00 Ver. K	0.10 MHz to 2500 MHz; Class C
Radiated Immunity Bulk Current Injection (BCI)	ES36500-4	20 MHz to 400 MHz, 100 mA, Class C
Radiated Immunity Anechoic chamber	ES36500-4	100 V/m, 80 MHz, to 2000 MHz, Class C,
Conducted Immunity on signal line	ES36500-4 Ver. K	Pulse a: -60 V peak Pulse b: +40 V peak, region I Level 4, Class C
ESD Test	ES36500-4 Ver. K	150 pF / 2000 Ω Contact: ± 4 , ± 6 kV Air: ± 8 kV U_C not connected
MECHANICAL TESTS		
Free Fall (Device not packaged)	IEC 60068-2-31 § 5.2: method 1 (05/2008) ISO 16750-3 § 4.3 (12/2012)	Height = 1 m; Concrete floor 3 axis; 2 directions by axis; 1 sample by axis
Package drop	JIS C60068-2-31: 1995	Drop test on 4 bottom edges, 4 bottom corners, concrete floor + topple test Measure Before/After test on EOL bench

Recommendations for use:**Storage:**

LEM transducers must be stored in a dry location, within the following ambient room conditions $< 40\text{ }^{\circ}\text{C}$ and $< 60\% \text{ RH}$. The product should be stored in its original packing. Ensure during storage and transport, the units are not damaged by applying excess weight to the packaging. The transducers must not be stored for more than three months. Ensure during storage and transport, the units are not damaged by applying excess weight to the boxes. Maximum stacking of pallet containers must not exceed two.

Unpacking:

When unpacking, care must be taken with cutting tools not to damage the transducer.

Handling:

LEM transducers must be handled with care and not undergo any shocks or falls (which may damage the unit). It is recommended to handle the transducer as long as possible inside its original packing (thermoform tray on customer's assembly station). It is forbidden to handle the transducers by their terminals. To avoid problems of ESD, it is recommended not to touch secondary terminals. Any rework operations are forbidden and will void the LEM warranty.

Installation:

The workshop and the people in contact with the transducers must be ESD protected. Before installing, be sure to check that the transducer corresponds to the required application. Be sure that the air gap between the housing of the transducer and the primary bar is sufficient to avoid damage in case of vibrations.

When uninstalling and reinstalling, thorough care needs to be taken for taped or screw-mounted transducers. Transducers mounted by clips must be scrapped after any dismounting.

单击下面可查看定价，库存，交付和生命周期等信息

[>>LEM\(莱姆\)](#)