

Voltage Transducer LV 100-1500

For the electronic measurement of voltages: DC, AC, pulsed..., with galvanic separation between the primary circuit and the secondary circuit.



RoHS

$$V_{PN} = 1500 \text{ V}$$

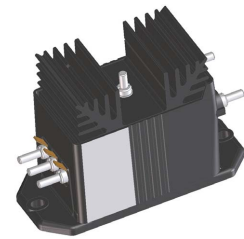

Electrical data

V_{PN}	Primary nominal RMS voltage	1500	V
V_{PM}	Primary voltage, measuring range	0 ... ± 2250	V
I_{PN}	Primary nominal RMS current	6.66	mA
R_M	Measuring resistance with $\pm 15 \text{ V}$		$R_{M \min}$ $R_{M \max}$
		@ $\pm 1500 \text{ V}_{\max}$	0 210 Ω
		@ $\pm 2250 \text{ V}_{\max}$	0 125 Ω
I_{SN}	Secondary nominal RMS current	50	mA
K_N	Conversion ratio	1500 V : 50 mA	
U_C	Supply voltage ($\pm 5 \%$)	± 15	V
I_C	Current consumption	$< 32 + I_S$	mA

Accuracy - Dynamic performance data

X	Accuracy @ $V_{PN}, T_A = 25 \text{ }^\circ\text{C}$	± 0.9	%
ε_L	Linearity error	< 0.1	%
I_O	Offset current @ $V_p = 0, T_A = 25 \text{ }^\circ\text{C}$	Typ	± 0.2 mA
		Max	± 0.2 mA
I_{OT}	Temperature variation of I_O 0 $^\circ\text{C}$... +70 $^\circ\text{C}$	± 0.2	mA
t_r	Step response time to 90 % of V_{PN}	< 120	μs

General data

T_A	Ambient operating temperature	0 ... +70	$^\circ\text{C}$
T_S	Ambient storage temperature	-25 ... +85	$^\circ\text{C}$
N_P/N_S	Turns ratio	15000 : 2000	
P_P	Total primary power loss	10	W
R_P	Resistance of primary winding @ $T_A = 25 \text{ }^\circ\text{C}$	225	k Ω
R_S	Resistance of secondary winding @ $T_A = 70 \text{ }^\circ\text{C}$	55	Ω
m	Mass	790	g
		Standard	EN 50178: 1997

Features

- Closed loop (compensated) voltage transducer using the Hall effect
- Insulating plastic case recognized according to UL 94-V0
- Primary resistor – incorporated within the housing.

Advantages

- Excellent accuracy
- Very good linearity
- Low temperature drift
- Optimized response time
- Wide frequency bandwidth
- No insertion losses
- High immunity to external interference.

Applications

- AC variable speed drives and servo motor drives
- Static converters for DC motor drives
- Uninterruptible Power Supplies (UPS)
- Power supplies for welding applications.

Application domain

- Industrial.

Voltage Transducer LV 100-1500

Insulation coordination

U_d	RMS voltage for AC insulation test, 50 Hz, 1 min	6	kV
\hat{U}_w	Impulse withstand voltage 1.2/50 μ s	16.5	kV
		Min	
d_{cp}	Creepage distance	55.12	mm
d_{ci}	Clearance	27.9	mm
CTI	Comparative tracking index (group I)	600	

Applications examples

According to **EN 50178** and **IEC 61010-1** standards and following conditions:

- Over voltage category OV 3
- Pollution degree PD2
- Non-uniform field

	EN 50178	IEC 61010-1
$d_{cp}, d_{ci}, \hat{U}_w$	Rated insulation voltage	Nominal voltage
Basic insulation	1500 V	1000 V
Reinforced insulation	1500 V	1000 V

Safety

This transducer must be used in limited-energy secondary circuits according to IEC 61010-1.



This transducer must be used in electric/electronic equipment with respect to applicable standards and safety requirements in accordance with the manufacturer's operating instructions.



Caution, risk of electrical shock

When operating the transducer, certain parts of the module can carry hazardous voltage (e.g. primary busbar, power supply). Ignoring this warning can lead to injury and/or cause serious damage.

This transducer is a build-in device, whose conducting parts must be inaccessible after installation. A protective housing or additional shield could be used. Main supply must be able to be disconnected.

Dimensions LV 100-1500 (in mm)

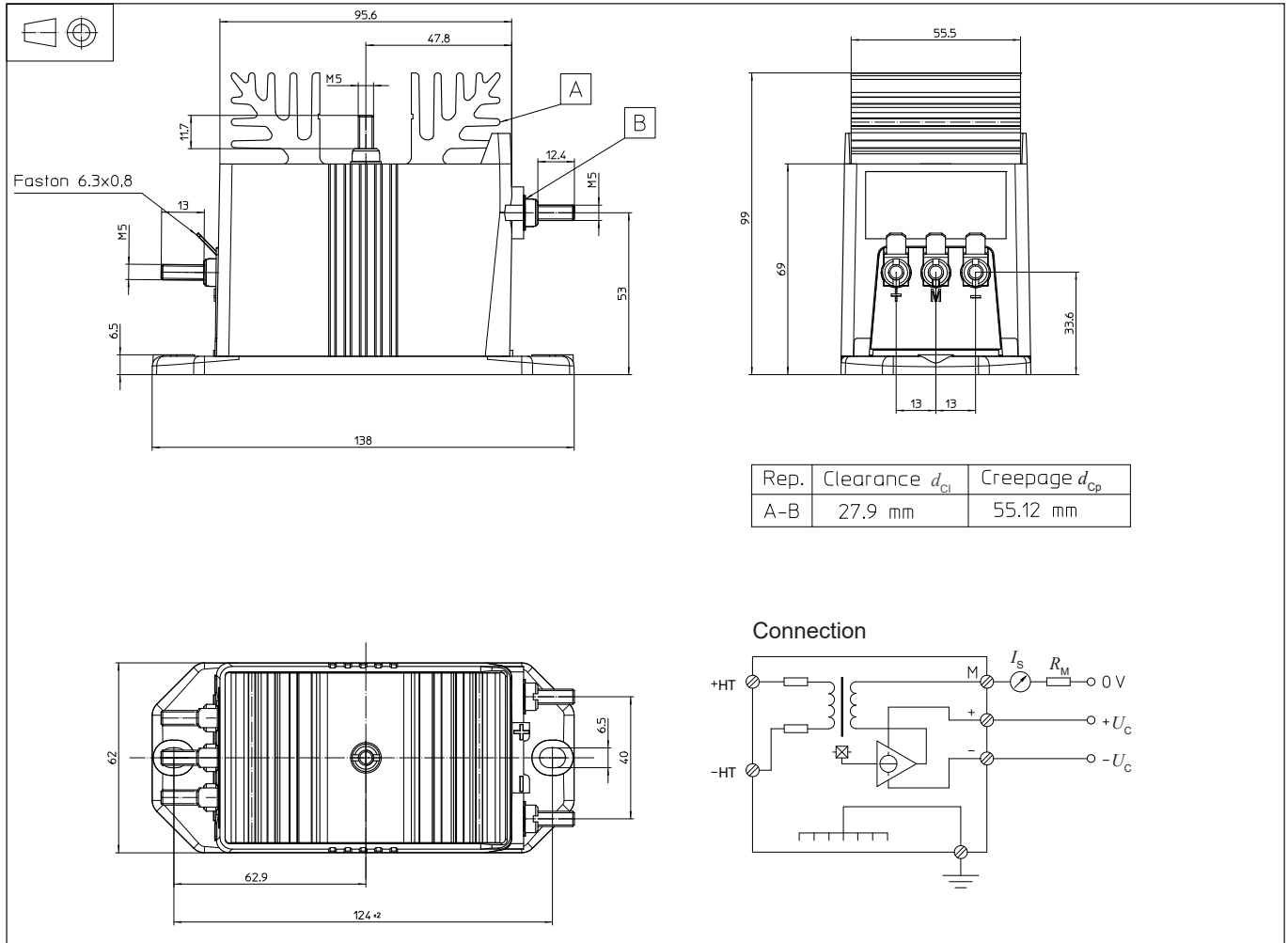

Mechanical characteristics

- General tolerance ± 0.3 mm
- Transducer fastening
 - 2 holes $\varnothing 6.5$ mm
 - 2 M6 steel screws
- Recommended fastening torque 5 N·m
- Connection of primary
 - M5 threaded studs
 - Recommended fastening torque 2.2 N·m
- Connection of secondary
 - Faston 6.3 × 0.8 mm
- Connection of ground
 - M5 threaded stud
 - Recommended fastening torque 2.2 N·m

Remarks

- I_S is positive when V_p is applied on terminal +HT.
- The primary circuit of the transducer must be linked to the connections where the voltage has to be measured.
- Installation of the transducer must be done unless otherwise specified on the datasheet, according to LEM Transducer Generic Mounting Rules. Please refer to LEM document N°ANE120504 available on our Web site: [Products/Product Documentation](#).
- This is a standard model. For different versions (supply voltages, turns ratios, unidirectional measurements...), please contact us.

单击下面可查看定价，库存，交付和生命周期等信息

[>>LEM\(莱姆\)](#)