

Voltage Transducer LV 100-1000/SP16

For the electronic measurement of voltages: DC, AC, pulsed..., with galvanic separation between the primary circuit and the secondary circuit.

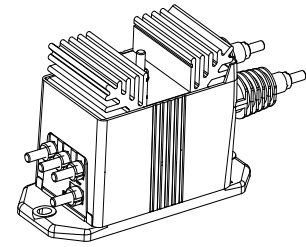

$$U_{PN} = 1000 \text{ V}$$



Electrical data

U_{PN}	Primary nominal RMS voltage	1000	V			
U_{PM}	Primary voltage, measuring range	0 ... ± 1700	V			
I_{PN}	Primary nominal RMS current	10	mA			
R_M	Measuring resistance	$R_{M \min}$	$R_{M \max}$			
		with $\pm 15 \text{ V}$	@ $\pm 1000 \text{ V}_{\max}$	0	210	Ω
			@ $\pm 1700 \text{ V}_{\max}$	0	100	Ω
		with $\pm 24 \text{ V}$	@ $\pm 1000 \text{ V}_{\max}$	0	410	Ω
		@ $\pm 1700 \text{ V}_{\max}$	0	220	Ω	
I_{SN}	Secondary nominal RMS current	50	mA			
S	Sensitivity	50	$\mu\text{A/V}$			
U_C	Supply voltage ($\pm 10 \%$)	$\pm 15 \dots 24$	V			
I_C	Current consumption	$< 37(@ \pm 24 \text{ V}) + I_S$	mA			

Accuracy - Dynamic performance data

ϵ_{tot}	Total error @ $U_{PN}, T_A = 25 \text{ }^\circ\text{C}$	± 0.9	%	
ϵ_L	Linearity error	< 0.1	%	
I_O	Offset current @ $U_p = 0, T_A = 25 \text{ }^\circ\text{C}$	Typ	Max	
			± 0.2	mA
I_{OT}	Temperature variation of I_O $-25 \text{ }^\circ\text{C} \dots +70 \text{ }^\circ\text{C}$	± 0.4	± 0.6	mA
t_{D90}	Delay time to 90 % of the final output value for U_{PN} step	< 100	μs	

General data

T_A	Ambient operating temperature	$-25 \dots +70$	$^\circ\text{C}$
T_{Ast}	Ambient storage temperature	$-40 \dots +85$	$^\circ\text{C}$
N_P/N_S	Turns ratio	10000 : 2000	
P_P	Total primary power loss	10	W
R_P	Resistance of primary winding @ $T_A = 25 \text{ }^\circ\text{C}$	100	k Ω
R_S	Resistance of secondary winding @ $T_A = 70 \text{ }^\circ\text{C}$	55	Ω
m	Mass	790	g
	Standard ¹⁾	EN 50155: 2017	

Note: ¹⁾ Additional information available on request.

Features

- Closed loop (compensated) voltage transducer using the Hall effect
- Insulating plastic case recognized according to UL 94-V0
- Primary resistor – incorporated within the housing.

Special features

- $U_{PM} = 0 \dots \pm 1700 \text{ V}$
- $U_C = \pm 15 \dots 24 (\pm 10 \%) \text{ V}$
- $T_A = -25 \text{ }^\circ\text{C} \dots +70 \text{ }^\circ\text{C}$
- Connection to secondary circuit on M5 threaded studs.

Advantages

- Excellent accuracy
- Very good linearity
- Low temperature drift
- Optimized delay time
- Wide frequency bandwidth
- High immunity to external interference.

Applications

- Single or three phase inverters
- Propulsion and braking choppers
- Propulsion converters
- Auxiliary converters
- Battery chargers.

Application Domain

- Railway (fixed installations and onboard).

Voltage Transducer LV 100-1000/SP16

Insulation coordination			
U_d	RMS voltage for AC insulation test, 50 Hz, 1 min	6 ¹⁾	kV
		1 ²⁾	kV
		Min	
d_{cp}	Creepage distance	164.8	mm
d_{cl}	Clearance	47.1	mm
CTI	Comparative tracking index (group I)	600	

Notes: ¹⁾ Between primary and secondary + shield.
²⁾ Between secondary and shield.

Safety



This transducer must be used in electric/electronic equipment with respect to applicable standards and safety requirements in accordance with the manufacturer's operating instructions.



Caution, risk of electrical shock

When operating the transducer, certain parts of the module can carry hazardous voltage (e.g. primary busbar, power supply). Ignoring this warning can lead to injury and/or cause serious damage.

This transducer is a build-in device, whose conducting parts must be inaccessible after installation. A protective housing or additional shield could be used.

Main supply must be able to be disconnected.

Dimensions LV 100-1000/SP16 (in mm)

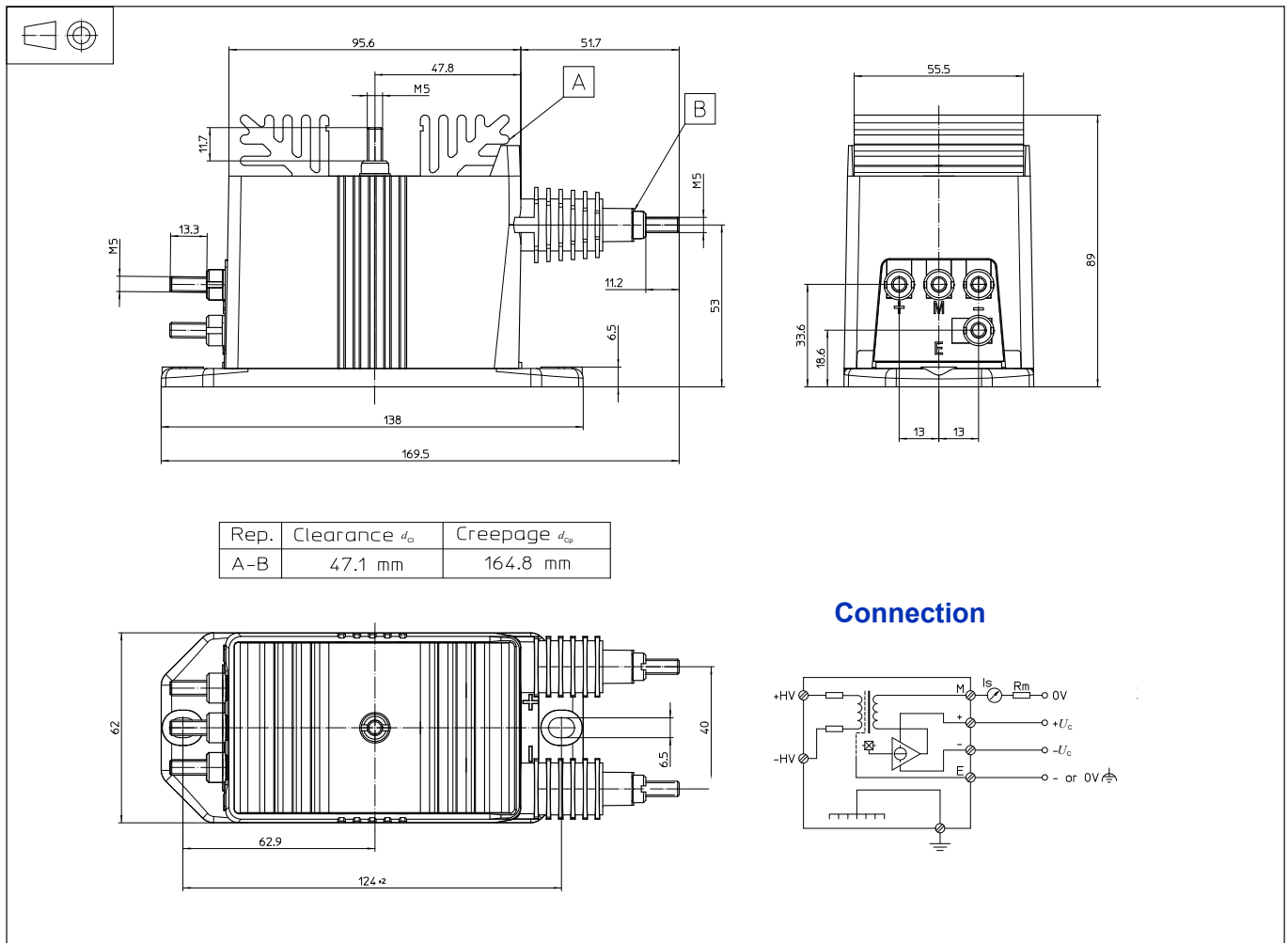

Mechanical characteristics

- General tolerance ± 0.5 mm
- Transducer fastening
 - 2 holes $\varnothing 6.5$ mm
 - 2 M6 steel screws
 - Recommended fastening torque 5 N·m
- Connection of primary
 - M5 threaded studs
 - Recommended fastening torque 2.2 N·m
- Connection of secondary
 - M5 threaded studs
 - Recommended fastening torque 2.2 N·m
- Connection of ground
 - M5 threaded stud
 - Recommended fastening torque 2.2 N·m

Remarks

- I_s is positive when U_p is applied on terminal +HV.
- The primary circuit of the transducer must be linked to the connections where the voltage has to be measured.
- Installation of the transducer must be done unless otherwise specified on the datasheet, according to LEM Transducer Generic Mounting Rules. Please refer to LEM document N°ANE120504 available on our Web site: <https://www.lem.com/en/file/3137/download/>.

单击下面可查看定价，库存，交付和生命周期等信息

[>>LEM\(莱姆\)](#)