

# Current Transducer ITZ 2000-SPR FLEX ULTRASTAB $I_{PM} = 125 \dots 2000 \text{ A}$

For ultra-high precision measurement of current: DC, AC, pulsed..., with galvanic separation between primary and secondary. Separate magnetic head and measuring electronics provides high flexibility and a selectable measuring range from 125 to 2000 A.



## Features

- Closed loop fluxgate
- Split design - separate head and rack electronics
- Analog output on 15-pin D-sub female output connector
- Status/interlock port on 9-pin D-sub male output connector
- Secondary current monitoring on BNC connector
- 4 mm banana sockets for secondary current output
- Full-featured indicator panel.

## Advantages

- Very high accuracy
- Excellent linearity
- Extremely low temperature drift
- Wide frequency bandwidth
- High immunity to external fields
- No insertion losses
- Low noise on output signal
- Low noise feedback to primary conductor.

## Applications

- Feedback element in high-precision, high-stability power supplies
- Calibration unit
- Absolute current standard reference
- Test and calibration of current sources
- Current extender for power systems
- Differential current measurement on power line
- Metrology applications.

## Standards

- EN 61010-1: 2001
- EN 61326-1: 2006
- EN 61000-3-2: 2006
- EN 61000-3-3: 1995 + A1: 2001 + A2: 2005.

## Application Domains

- Industrial
- Laboratory
- Medical.

**Insulation coordination**

Parameter	Symbol	Unit	Value	Comment
Rated insulation RMS voltage, basic insulation	$U_{Nm}$	V	2500	IEC 61010-1 conditions - overvoltage cat III - pollution degree 2
Rated insulation RMS voltage, reinforced insulation	$U_{Nm}$	V	1250	IEC 61010-1 conditions - overvoltage cat III - pollution degree 2
Rated insulation RMS voltage, basic insulation	$U_{Nm}$	V	2500	EN 50178 conditions - overvoltage cat III - pollution degree 2
Rated insulation RMS voltage, reinforced insulation	$U_{Nm}$	V	1250	EN 50178 conditions - overvoltage cat III - pollution degree 2
RMS voltage for AC insulation test, 50/60 Hz, 1 min	$U_d$	kV	10.8	
Impulse withstand voltage 1.2/50 $\mu$ s	$U_{Ni}$	kV	19.9	
Clearance (pri. - sec.)	$d_{Cl}$	mm	25	Shortest distance through air
Creepage distance (pri. - sec.)	$d_{Cp}$	mm	25	Shortest path along device body
Comparative tracking index	$CTI$	-	100	

**Environmental and mechanical characteristics**

Parameter	Symbol	Unit	Min	Typ	Max	Comment
Ambient operating temperature HEAD	$T_A$	°C	0		55	
Ambient operating temperature ELECTRONICS	$T_A$	°C	10		40	
Ambient storage temperature HEAD and ELECTRONICS	$T_{A\text{st}}$	°C	-20		85	
Relative humidity	$RH$	%	20		80	Non-condensing
Dimensions ELECTRONICS		mm				482 × 88 × 430 see drawing (page 14)
Dimensions HEAD						see drawing (page 14)
Mass rack electronics	$m$	kg		8.4		
Mass head	$m$	kg		4.6		

**Electrical data**

 At  $T_A = 25\text{ °C}$  unless otherwise noted.

Parameter	Symbol	Unit	Min	Typ	Max	Comment
Primary continuous direct current <sup>3)</sup>	$I_{PNDC}$	A	±125		±2000	
Primary nominal RMS current	$I_{PN}$	A	125		2000	
Primary current, measuring range <sup>3)</sup>	$I_{PM}$	A	±177		±2829	
Measuring resistance	$R_M$	Ω	0		1.5	
Secondary current	$I_S$	A	-1		1	
Conversion ratio <sup>4)</sup>	$N_P / N_S$		1:125		1:2000	
Resistance of secondary winding	$R_S$	Ω		5.8		
Primary withstand peak current <sup>1)</sup>	$\hat{I}_{Pmax}$	kA			10	
Mains supply RMS voltage		V	100		240	
Rated power supply frequency	$f$	Hz		50/60		
Power consumption $I_P = 0\text{ A}$ @ Mains supply = 230 V RMS	$P_C$	W VA		34 79		Average Peak
Power consumption $I_P = I_{PNDC}$ (2000 A) @ Mains supply = 230 V RMS	$P_C$	W VA		48 104		Average Peak
RMS noise voltage 0 ... 10 Hz <sup>2)</sup>	$U_{no}$	ppm			0.01	
RMS noise voltage 0 ... 10 kHz <sup>2)</sup>					7	
RMS noise voltage 0 ... 100 kHz <sup>2)</sup>					42	
Re-injected RMS noise on primary bus bar 0 ... 100 kHz		μV			10	
Electrical offset current <sup>2)</sup>	$I_{OE}$	ppm	-2		2	
Temperature coefficient of $I_{OE}$ <sup>2)</sup>	$TCI_{OE}$	ppm/K	-0.1		0.1	10 °C ... 40 °C
Offset stability <sup>2)</sup>		ppm/month	-1		1	
Linearity error <sup>2)</sup>	$\epsilon_L$	ppm	-2		2	
Delay time to 90 % of the output value for $I_{PNDC}$ step	$t_{D90}$	μs			1	With a $di/dt \geq 20\text{ A}/\mu\text{s}$
Frequency bandwidth (±3 dB)	$BW$	kHz	0	80		Small-signal bandwidth, 1 % of $I_{PNDC}$
$di/dt$ accurately followed	$di/dt$	A/μs	20			

- Notes:**
- 1) Single pulse of 100 ms only, not AC. The transducer may require a few seconds to return to normal operation when autoreset system is running.
  - 2) All ppm figures refer to full-scale which corresponds to a secondary current ( $I_S$ ) output of 1 A
  - 3) Programmed in the range 125 to 2000 A with a resolution of 125 A; this is done by using a programming plug (see page 10)
  - 4) Depending on programming plug.

Typical power consumption

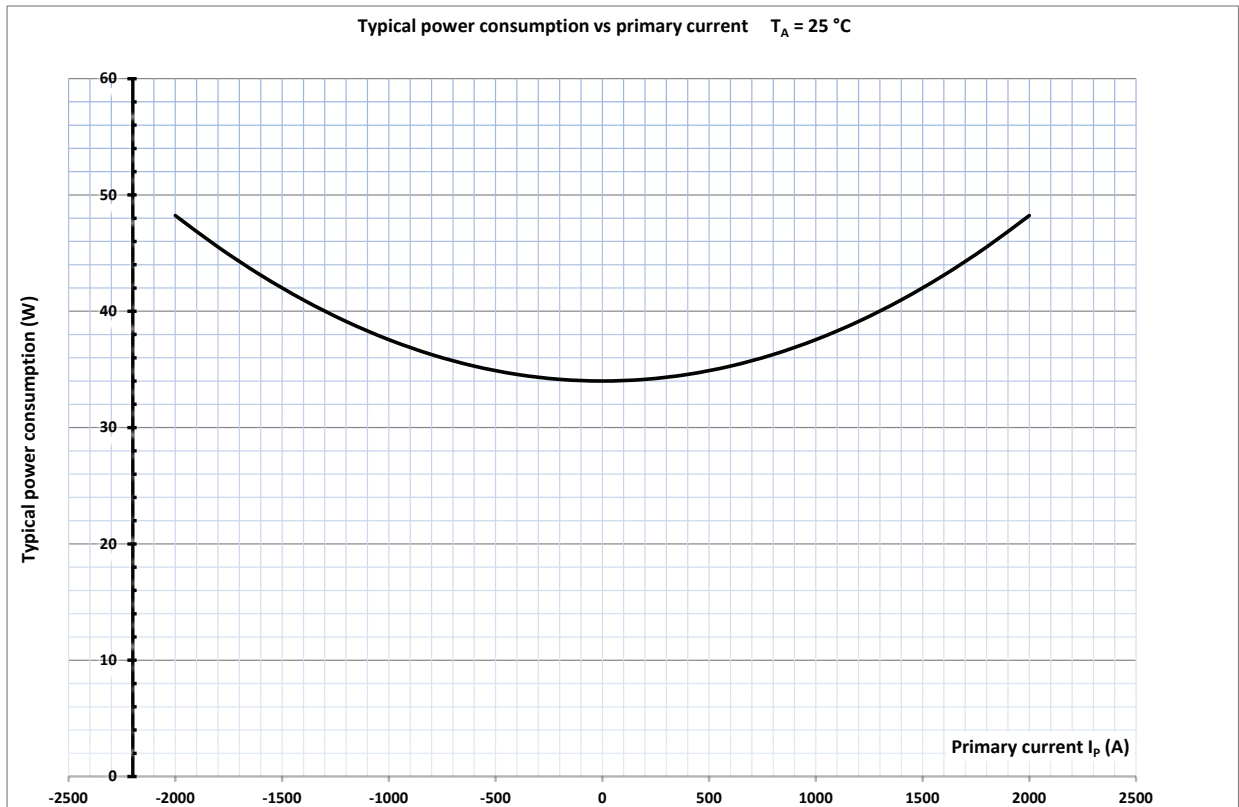

System overview

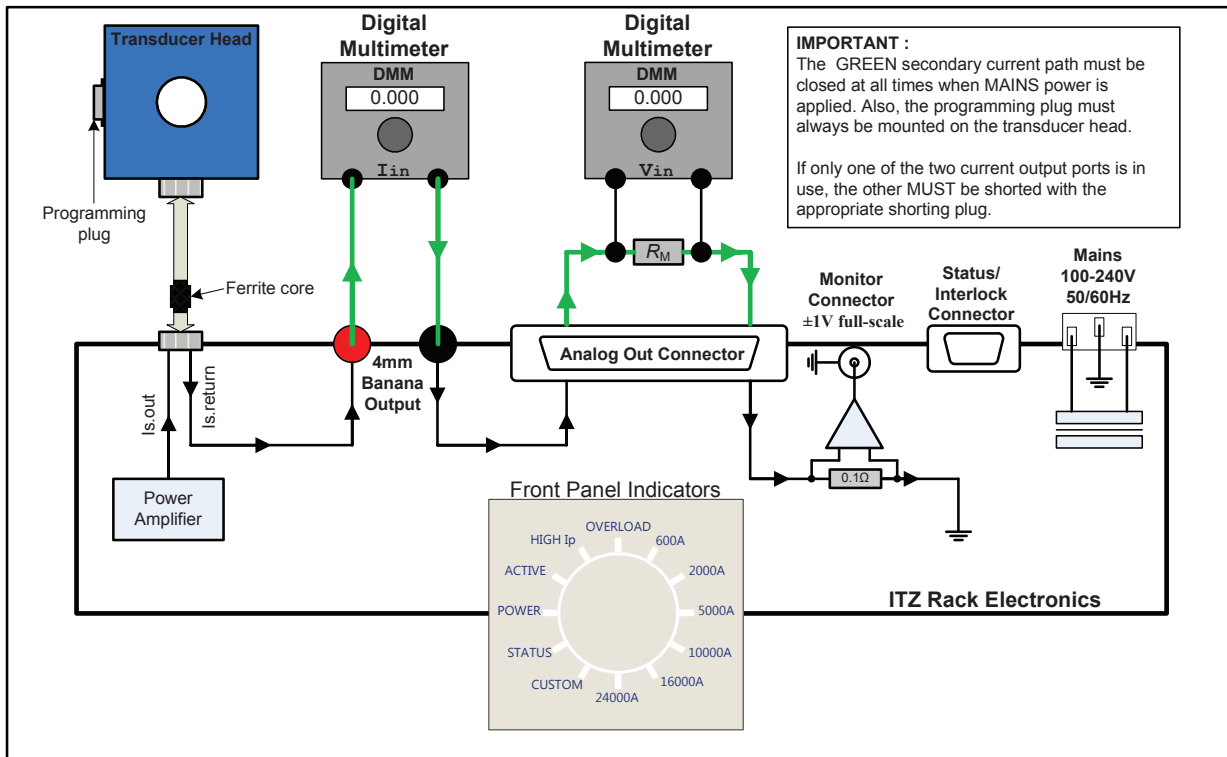

Front panel indicators

When the mains supply voltage is set up, the rack electronics starts and initializes itself. After this process, the LEDs POWER, STATUS and 2000 A light up. The LEDs present on this panel display information about conditions which affect the operation of the transducer. They are defined in the following table:

LED	Description
POWER (blue LED)	This LED is lit when the mains supply voltage is present
ACTIVE (yellow LED)	This LED is lit when $I_p$ is higher than approximately 1 % of $I_{PN DC}$
HIGH $I_p$ (yellow LED)	This LED is lit when $I_p$ is higher than approximately 105 % of $I_{PN DC}$
OVERLOAD (red LED)	This LED is lit when the transducer head saturates due to excessive primary current.
600 A ... 24000 A (yellow LED)	These LEDs are lit when a transducer head with the corresponding full-scale range is connected to the rack electronics. For ITZ 2000-SPR, only LED 2000 A is lit, and the others may be ignored.
CUSTOM (yellow LED)	Reserved for a custom head configuration.
STATUS (green LED)	This LED is lit when the unit status is OK (Normal operation).

Back panel

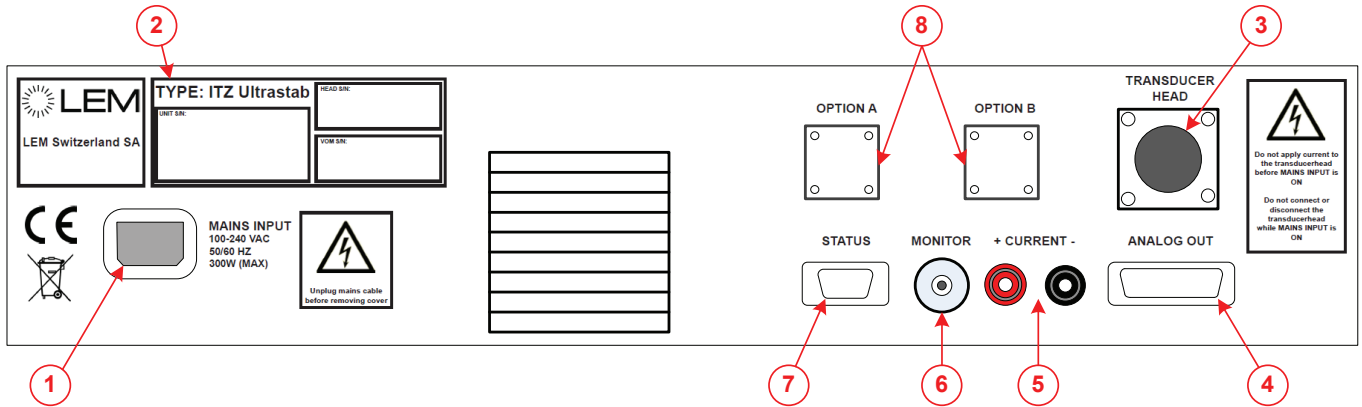

Reference	Description
1	IEC power inlet: This connector accepts a standard IEC power cord (supplied)
2	Type / Serial number plate. Three individual S/Ns may be listed here: One for the ITZ electronics, one for the matching head and one (optional) for the installed voltage output module
3	Transducer head: Connection to the transducer head
4	Analog out: Output connection to a DMM or other equipment, 15-pin D-Sub female UNC 4-40 screw lock
5	Current ±: Secondary current output
6	Monitor: Voltage output with a buffered replica of the secondary current
7	Status/Interlock signal outputs, 9-pin D-Sub male UNC 4-40 screw lock
8	Option A+B: These positions are for future expansion or customization (not used)

**Status /Interlock Port - electrical specification**

All signals on the Status/Interlock port are optically isolated, Photocouplers type, floating Collector and Emitter. Four signals are present on the port, each having two dedicated floating pins in the SUBD9 Male connector:

- Collector (C)
- and
- Emitter (E)

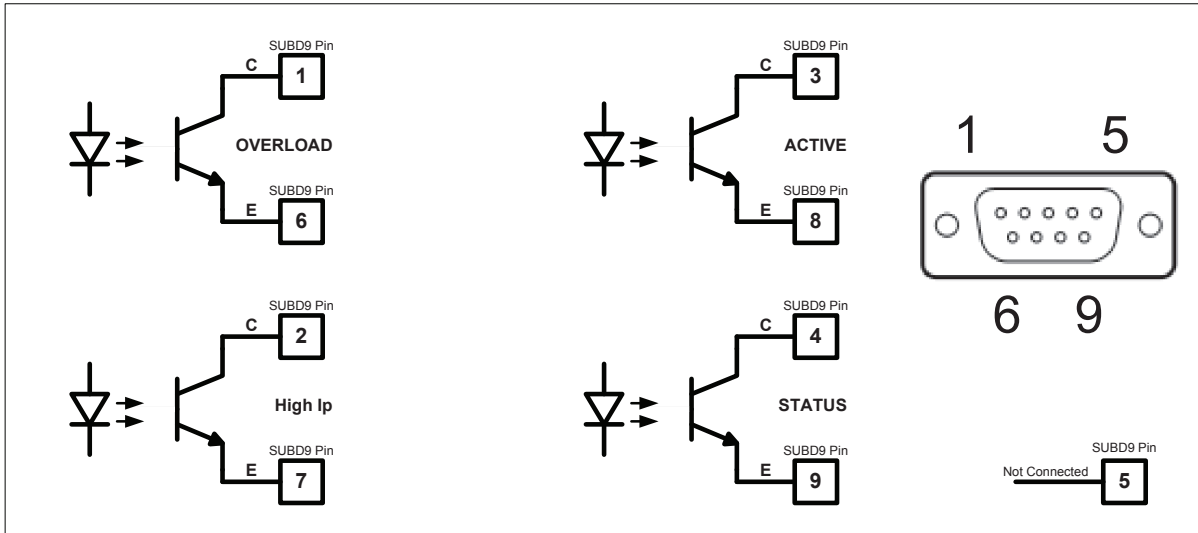

**Status /Interlock port wiring**

Depending on how each signal is wired, it can be “Active Low” or “Active High” as shown below:

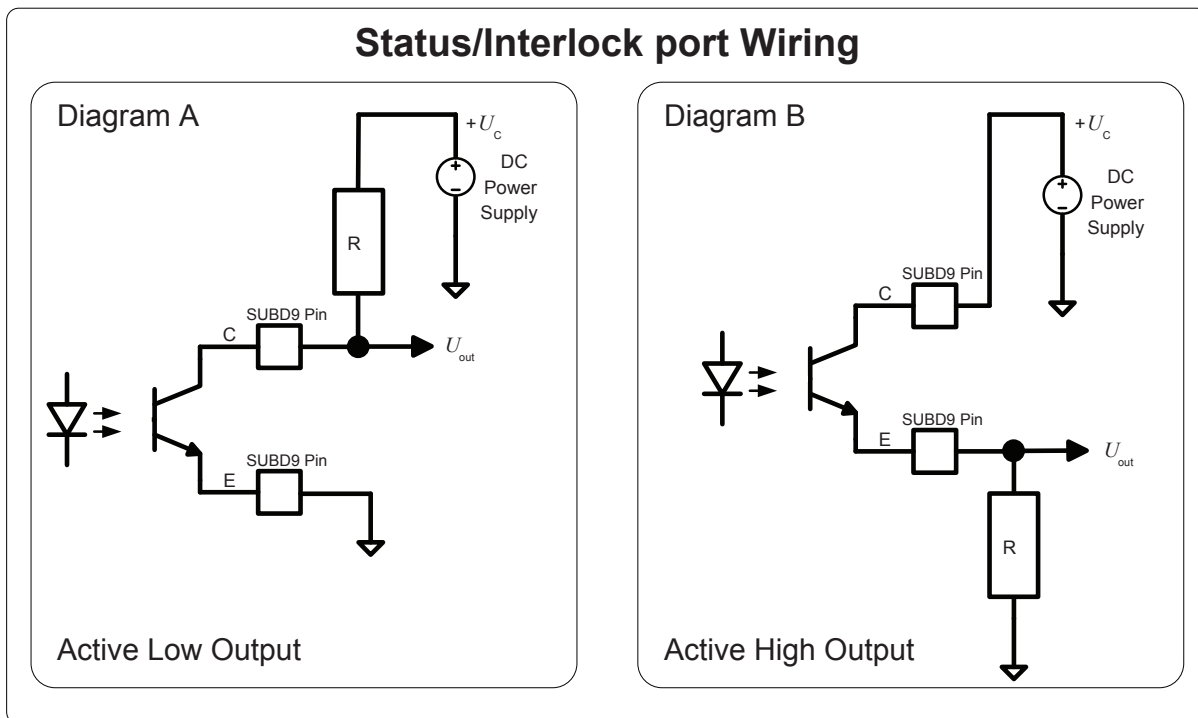

In the Diagram A Active Low Output, the output signal  $U_{out}$  switches to GND when the corresponding LED is ON.  
 In the Diagram B Active High Output, the output signal  $U_{out}$  switches to  $+U_c$  when the corresponding LED is ON.  
 When the output signal  $U_{out}$  is switched to GND, its value is lower than 0.2 V.  
 When the output signal  $U_{out}$  is switched to  $+U_c$ , its value is equal to  $+U_c$ .

In case diagram A, the following table shows how each individual output signal acts:

Output signal	$U_{out}$	Description
OVERLOAD	< 0.2 V	The transducer head is saturated due to excessive primary current
	+ $U_C$	The transducer head is not saturated
High $I_p$	< 0.2 V	The primary current is higher than 105 % of nominal full-scale output
	+ $U_C$	The primary current is lower than 105 % of nominal full-scale output
ACTIVE	< 0.2 V	The primary current is higher than approximately 1 % of nominal full-scale output
	+ $U_C$	The primary current is lower than approximately 1 % of nominal full-scale output
STATUS	< 0.2 V	When the unit status is OK (Normal operation)
	+ $U_C$	When the unit status is not OK (Supply fault, over-temperature conditions and Current overloads or No detected head)

In case diagram B, the following table shows how each individual output signal acts:

Output signal	$U_{out}$	Description
OVERLOAD	+ $U_C$	The transducer head is saturated due to excessive primary current
	< 0.2 V	The transducer head is not saturated
High $I_p$	+ $U_C$	The primary current is higher than 105 % of nominal full-scale output
	< 0.2 V	The primary current is lower than 105 % of nominal full-scale output
ACTIVE	+ $U_C$	The primary current is higher than approximately 1 % of nominal full-scale output
	< 0.2 V	The primary current is lower than approximately 1 % of nominal full-scale output
STATUS	+ $U_C$	When the unit status is OK (Normal operation)
	< 0.2 V	When the unit status is not OK (Supply fault, over-temperature conditions and Current overloads or No detected head)

The power supply voltage + $U_C$  must be between 4 V and 60 V DC and the resistor value must be chosen between a minimum value  $R_{min}$  and a maximum value  $R_{max}$  calculated by using the following equations:

$$R_{min} \text{ (k}\Omega\text{)} = \frac{+U_C}{3.4} \text{ and } R_{max} \text{ (k}\Omega\text{)} = \frac{+U_C}{1.7}$$

Some recommended standard values of  $R$  are given in the following table:

Power supply voltage + $U_C$	$R_{min}$ (k $\Omega$ )	$R_{max}$ (k $\Omega$ )	$R$ Standards values $\pm 5\%$
5 V	1.5	3	1.8 k $\Omega$ or 2.2 k $\Omega$
12 V	3.5	7	4.7 k $\Omega$ or 6.8 k $\Omega$
24 V	7	14	10 k $\Omega$ or 12 k $\Omega$

### Absolute maximum ratings

Parameter	Symbol	Specification	Unit
Power supply voltage	+ $U_C$	60	V
Maximum Off-state Collector-Emitter Voltage	$U_{CE \text{ off}}$	60	V
Maximum reverse Off-state Collector-Emitter Voltage	$U_{CE \text{ off}}$	5	V
Maximum ON-state Collector-Emitter Current	$I_{CE}$	10	mA

Stresses beyond those listed under absolute maximum ratings may cause permanent damage to the status/interlock signal outputs.



### Sweep function during overload status

The overload occurs when the primary current  $I_p$  exceeds a trip level such that the fluxgate detector becomes completely saturated and, consequently, the transducer will switch from normal operation to overload mode.

This trip level is guaranteed to be greater than 110 % of  $I_{P\ N\ DC}$  and its actual value depends on operating conditions such as temperature and measuring resistance.

When this happens, the ITZ rack electronics will automatically begin to sweep in order to lock on to the primary current again and the measuring can resume when the primary current returns in the nominal range between  $-I_{P\ N\ DC}$  and  $+I_{P\ N\ DC}$ .

In sweep mode, the secondary current will be a slope between  $-1\ A$  and  $+1\ A$ .

### Thermal protection

The ITZ 2000-SPR has thermal shutdown circuitry that protects the electronics from damage.

The thermal protection circuitry disables the measuring circuit when the rack electronics temperature reaches approximately 65 °C and allows the transducer to cool. When this occurs, the status LED is switched off.

When the rack electronics temperature cools to approximately 60 °C, the measuring circuit is automatically re-enabled and the status LED is again lit.

### Over current protection - Electrical specifications

The over current occurs when the primary current exceeds 120 % of  $I_{P\ N\ DC}$ .

To detect the over current with primary AC, the secondary current is full-wave rectified and is time-averaged by a low-pass filter. Depending on the frequency range of the primary current, two cases appear:

- Low frequency range: DC – 1.6 Hz (over current slow)

In this case, the over current trip level is set to 120 % of  $I_{P\ N\ DC}$ .

The secondary current is tracked until the primary AC peak exceeds this trip level. Then, the rack electronics shut down the measuring circuit and wait until the primary AC peak becomes lower than the set trip level.

- High frequency range: 1.6 Hz – 1.6 KHz (over current fast)

In this case, the over current trip level is set to 160 % of  $I_{P\ N\ DC}$ .

The secondary current is tracked until the primary AC peak exceeds this trip level. Then, the rack electronics shut down the measuring circuit and wait until the primary AC peak becomes lower than the set trip level.

The frequency response characteristics of the over current trip level with a sine-wave primary AC is illustrated by the following curve:

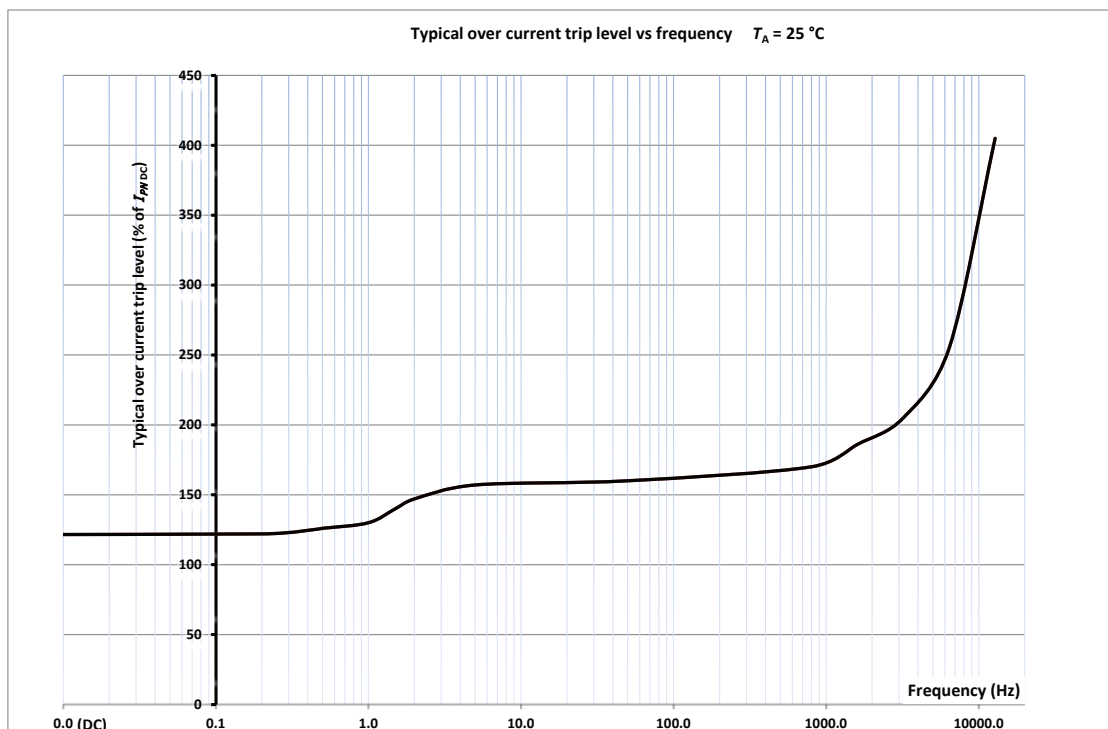

The table shown below summarizes various frequency values and the typical value of over current trip level to detect over current state:

Primary current frequency (Hz)	Typical over current trip level to detect over current state
DC (0 Hz)	120 % of $I_{PN DC}$
1	130 % of $I_{PN DC}$
1.5	140 % of $I_{PN DC}$
50	160 % of $I_{PN DC}$
800	170 % of $I_{PN DC}$
1600	186 % of $I_{PN DC}$

Under these conditions:

- The signal Status (Contact between Pin 4:C and Pin 9:E) switches off, this signal becomes open (No current from collector to emitter) to indicate that the unit is not OK.
- The status green LED located on the front panel switches off (fault state)
- The transducer is protected against damage that the over current primary AC may cause to the electronics.

The transducer will automatically starts again to work when the primary AC peak becomes lower than the trip level indicated in the table above.

### Transducer head description

Connect the transducer head to the electronics rack using the supplied transducer head cable and mount the programming plug in the 25-pin D-Sub connector on the transducer head.

The side of cable where there is the ferrite must be connected to the rack electronics.

The transducer head cable is available in three lengths: 10, 20 and 30 meters.

For more information, see section "ITZ mandatory accessories" on page 13.

### Programmability

The programmability consists of a programming plug connected in the 25-pin D-Sub connector on the transducer head as shown in the figure below:

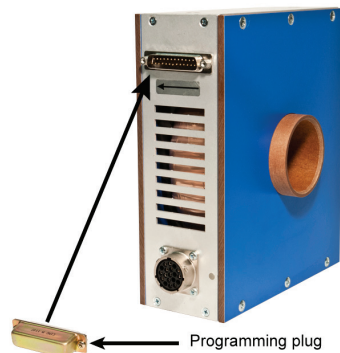

It allows the conversion ratio to be changed. By modifying the conversion ratio, the nominal primary current can be decreased while keeping the secondary output current constant. The burden resistor is unchanged.

The programming is done by dividing the secondary winding in multiple windings. The programming plug connects the individual windings in series summing up the number of windings to obtain the desired conversion ratio.

In the ITZ 2000-SPR head, the nominal primary current can be programmed in the range of 125 A to 2000 A with a resolution of 125 A.

The most commonly available programming plugs are:

- ITZ PR 2000 A–125 A
- ITZ PR 2000 A–375 A
- ITZ PR 2000 A–1875 A
- ITZ PR 2000 A–2000 A

For more information, see section "ITZ mandatory accessories" on page 13.

**Programming example to 125 A:**

An ITZ 2000-SPR transducer head programmed to 125 A will produce 1 A when the primary current is equal to 125 A. The current conversion ratio of the transducer is then:

$$N_p / N_s = \frac{1A}{125 A} = 1 \cdot 125$$

**Programming example to 375 A:**

An ITZ 2000-SPR transducer head programmed to 375 A will produce 1 A when the primary current is equal to 375 A. The current conversion ratio of the transducer is then:

$$N_p / N_s = \frac{1A}{375 A} = 1 \cdot 375$$

**Analog output connector**

Normally the provided analog output cable should be used. It is also possible to configure your own output cable, bearing the following description in mind.

The female 15-pin D-Sub connector Analog out connector contains the following signals:

1. Current return
2. Current return
3. Current return
4. No connection
5. No connection
6. Ground
7. No connection
8. No connection
9. Current out
10. Current out
11. Current out
12. No connection
13. No connection
14. No connection
15. No connection

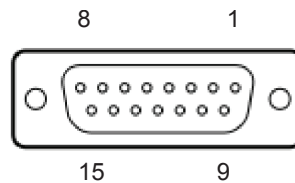

The pins 1 to 3 are internally shorted by rack electronics. It is the same for pins 9 to 11.

Details of further considerations relating to connect the analog output connector directly to a current measuring device can be found in the ITZ FLEX ULTRASTAB user guide.

## Secondary current monitoring

The rack electronics incorporates a  $0.1 \Omega$  resistance in series with the measuring resistance for the monitoring of the secondary current.

A BNC connector located on the rear panel provides a low-precision voltage output  $\pm 1$  V full-scale which indicates a secondary current flowing through the measuring resistance and the  $0.1 \Omega$  resistance.

The voltage on this connector is equal to  $(I_p \text{ (A)} \times 0.1 \Omega \times 10) / N_p / N_s$  (Volt).

As one example, if  $I_p$  is 2000 A and  $N_p / N_s$  is 2000, the voltage on this connector is 1 V.

Similarly, if  $I_p$  is  $-2000$  A and  $N_p / N_s$  is 2000, the voltage on this connector is  $-1$  V.

As another example, if  $I_p$  is 62.5 A and  $N_p / N_s$  is 125, the voltage on this connector is 0.5 V.

Similarly, if  $I_p$  is  $-62.5$  A and  $N_p / N_s$  is 125, the voltage on this connector is  $-0.5$  V.

## Delivery package

The LEM ITZ 2000-SPR FLEX ULTRASTAB package should contain:

- 19-inch rack-mount ITZ FLEX ULTRASTAB electronics
- Transducer head
- European (Schuko) and US mains cable with three-pole IEC female connector
- Cable for connecting head and rack electronics
- Analog output cable
- Calibration certificate (optional)
- Programming plug

## Safety

This transducer must be used in limited-energy secondary circuits according to IEC 61010-1.



This transducer must be used in electric/electronic equipment with respect to applicable standards and safety requirements in accordance with the manufacturer's operating instructions.



Caution, risk of electrical shock

When operating the transducer, certain parts of the module can carry hazardous voltage (eg. primary busbar, power supply). Ignoring this warning can lead to injury and/or cause serious damage.

This transducer is a build-in device, whose conducting parts must be inaccessible after installation.

A protective housing or additional shield could be used.

Mains supply must be able to be disconnected.

## Remark

Installation of the transducer must be done unless otherwise specified on the datasheet, according to LEM Transducer Generic Mounting Rules. Please refer to LEM document N°ANE120504 available on our Web site: [Products/Product documentation](#).

## ITZ 2000-SPR FLEX ULTRASTAB

ITZ mandatory accessories	Available material	Available length	Available programming plugs
Transducer HEAD cable (interconnecting cable)	Halogeneous Non-Halogeneous	10 m 20 m 30 m Special	NA
Analog output cable	Non-Halogeneous	1.5 m Special	NA
Programming	NA	NA	ITZ PR 2000 A-125 A ITZ PR 2000 A-375 A ITZ PR 2000 A-1875 A ITZ PR 2000 A-2000 A Special

NA = Not Applicable

ITZ calibration (optional)	Available calibration
Calibration	5 points 11 points Special

Dimensions - rack electronics (in mm)

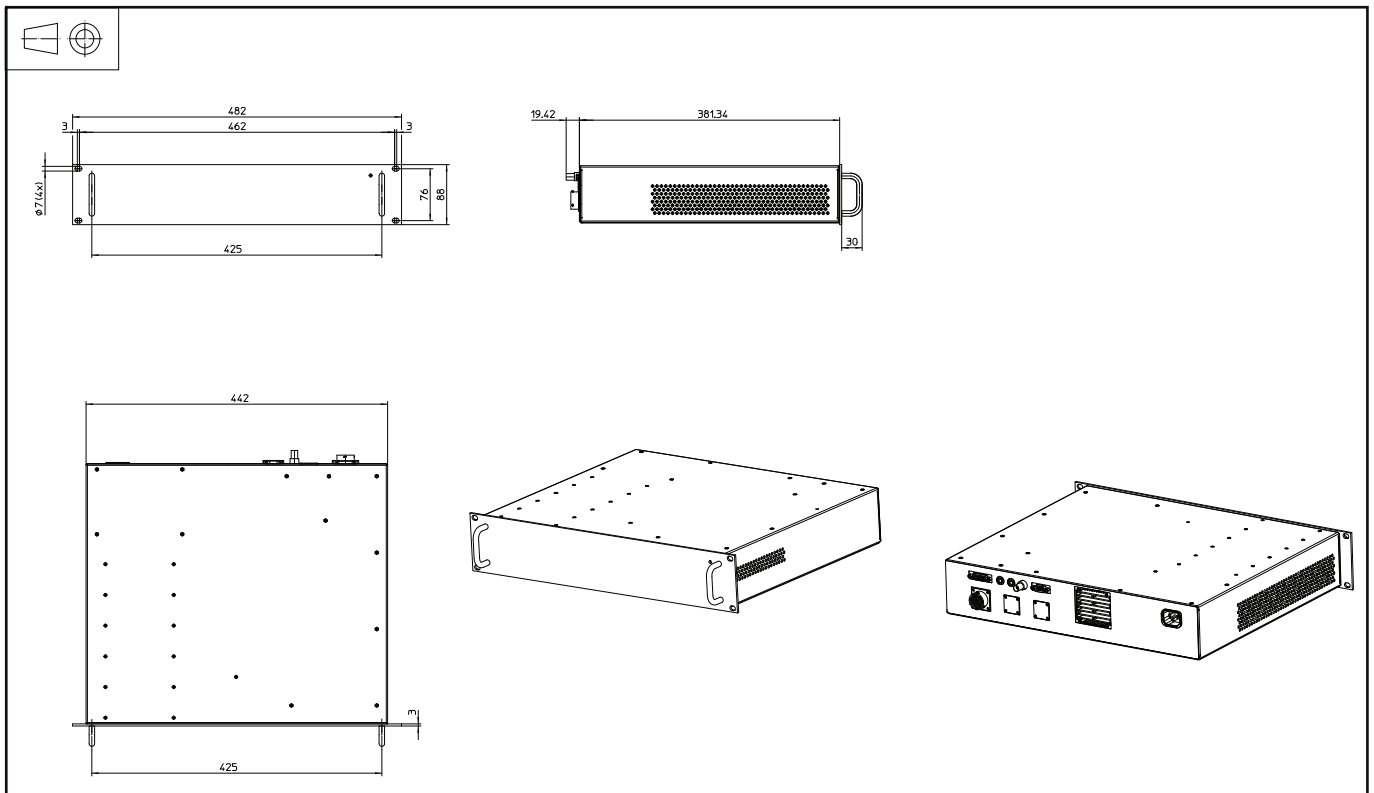

Dimensions - ITZ 2000 measuring head (in mm)

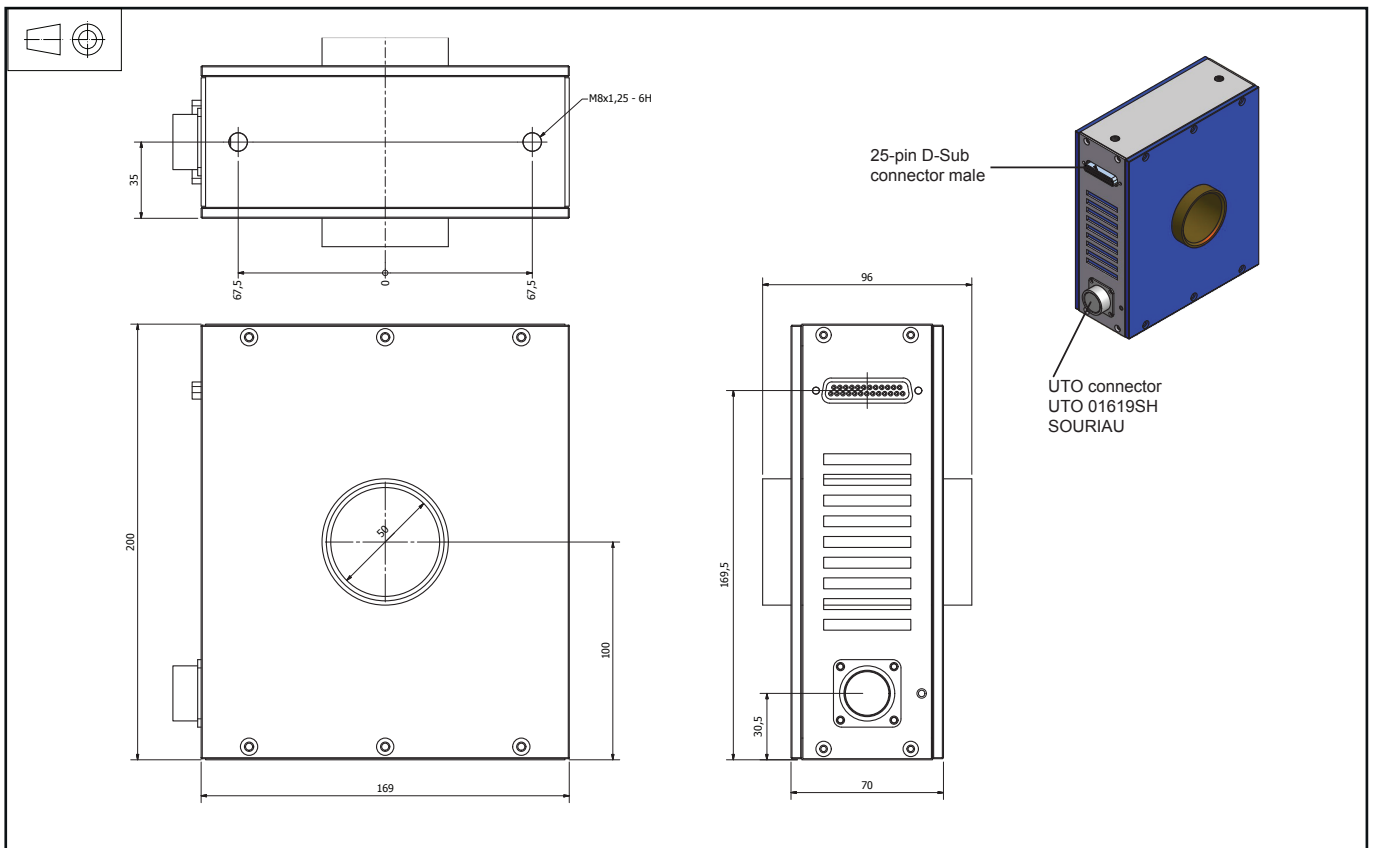

单击下面可查看定价，库存，交付和生命周期等信息

[>>LEM\(莱姆\)](#)