

Current Transducer HOP 800 ... 2000-SB

$I_{PN} = 800 \dots 2000 \text{ A}$

For the electronic measurement of currents: DC, AC, pulsed..., with galvanic separation between the primary circuit and the secondary circuit.

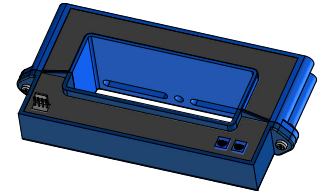

Electrical data

Type	Primary nominal RMS current I_{PN} (A)	Primary current, measuring range I_{PM} (A)	
HOP 800-SB	800	± 1600	
HOP 1000-SB	1000	± 2000	
HOP 1500-SB	1500	± 3000	
HOP 2000-SB	2000	± 3000	
U_{out}	Output voltage (Analog)	± 4	V
R_L	Load resistance	> 10	k Ω
U_C	Supply voltage ($\pm 5\%$)	$\pm 12 \dots 15$	V
I_C	Current consumption	20	mA

Accuracy - Dynamic performance data

ϵ_{tot}	Total error ¹⁾ @ $I_{PN}, T_A = 25^\circ\text{C}, @ \pm 12 \dots 15 \text{ V} (\pm 5\%)$	$\leq \pm 2$		%
ϵ_L	Linearity error ¹⁾	$\leq \pm 1$		%
U_{OE}	Electrical offset voltage @ $I_p = 0, T_A = 25^\circ\text{C}$	Typ ± 10	Max ± 20	mV
U_{OM}	Magnetic offset voltage @ $I_p = 0$ and specified R_M , after an overload of $3 \times I_{PN}$	± 10	± 20	mV
U_{OT}	Temperature variation of U_o $-10^\circ\text{C} \dots +70^\circ\text{C}$	± 10	± 25	mV
TCU_{out}	Temperature coefficient of U_{out} $-10^\circ\text{C} \dots +70^\circ\text{C}$	± 80	± 150	mV
t_{D90}	Delay time to 90 % of the final output value for I_{PN} ²⁾ step < 10			μs
BW	Frequency bandwidth (-1 dB)	DC ... 10		kHz

General data

T_A	Ambient operating temperature	$-10 \dots +70$	$^\circ\text{C}$
T_{Ast}	Ambient storage temperature	$-25 \dots +85$	$^\circ\text{C}$
m	Mass	590	g
	Standards	EN 50178: 1997 UL 508: 2013	

Notes: ¹⁾ Excludes the electrical offset

²⁾ For a $di/dt = 50 \text{ A}/\mu\text{s}$.

Features

- Open loop Hall effect transducer
- Insulating plastic case recognized according to UL 94-V0.

Advantages

- Low power consumption
- Split core easy for mounting
- Through-hole, no insertion losses.

Applications

- Power supplies for TELECOM (monitoring & measuring)
- Uninterruptible Power Supplies (UPS)
- Switched Mode Power Supplies (SMPS)
- Electrical chemistry
- Chopper
- Battery supplied applications.

Application domain

- Industrial.

Current Transducer HOP 800 ... 2000-SB

Insulation coordination

U_d	RMS voltage for AC insulation test, 50 Hz, 1 min	5	kV
U_{Ni}	Impulse withstand voltage 1.2/50 μ s	> 12	kV
U_e	Partial discharge extinction RMS voltage	> 1.5	kV
		Min	
d_{Cp}	Creepage distance ¹⁾	21.2	mm
d_{Cl}	Clearance ¹⁾	16	mm
CTI	Comparative tracking index (group IIIa)	250	

Note: ¹⁾On housing from pin to primary hole.

Applications examples

According to EN 50178 and IEC 61010-1 standards and following conditions:

- Over voltage category OV 3
- Pollution degree PD2
- Non-uniform field

	EN 50178	IEC 61010-1
d_{Cp}, d_{Cl}, U_{Ni}	Rated insulation voltage	Nominal voltage
Basic insulation	1500 V	2000 V
Reinforced insulation	1000 V	1000 V

Safety

This transducer must be used in limited-energy secondary circuits according to IEC 61010-1.



This transducer must be used in electric/electronic equipment with respect to applicable standards and safety requirements in accordance with the manufacturer's operating instructions.



Caution, risk of electrical shock

When operating the transducer, certain parts of the module can carry hazardous voltage (eg. primary busbar, power supply).

Ignoring this warning can lead to injury and/or cause serious damage.

This transducer is a build-in device, whose conducting parts must be inaccessible after installation.

A protective housing or additional shield could be used.

Main supply must be able to be disconnected.

Dimensions HOP 800 ... 2000-SB (in mm)

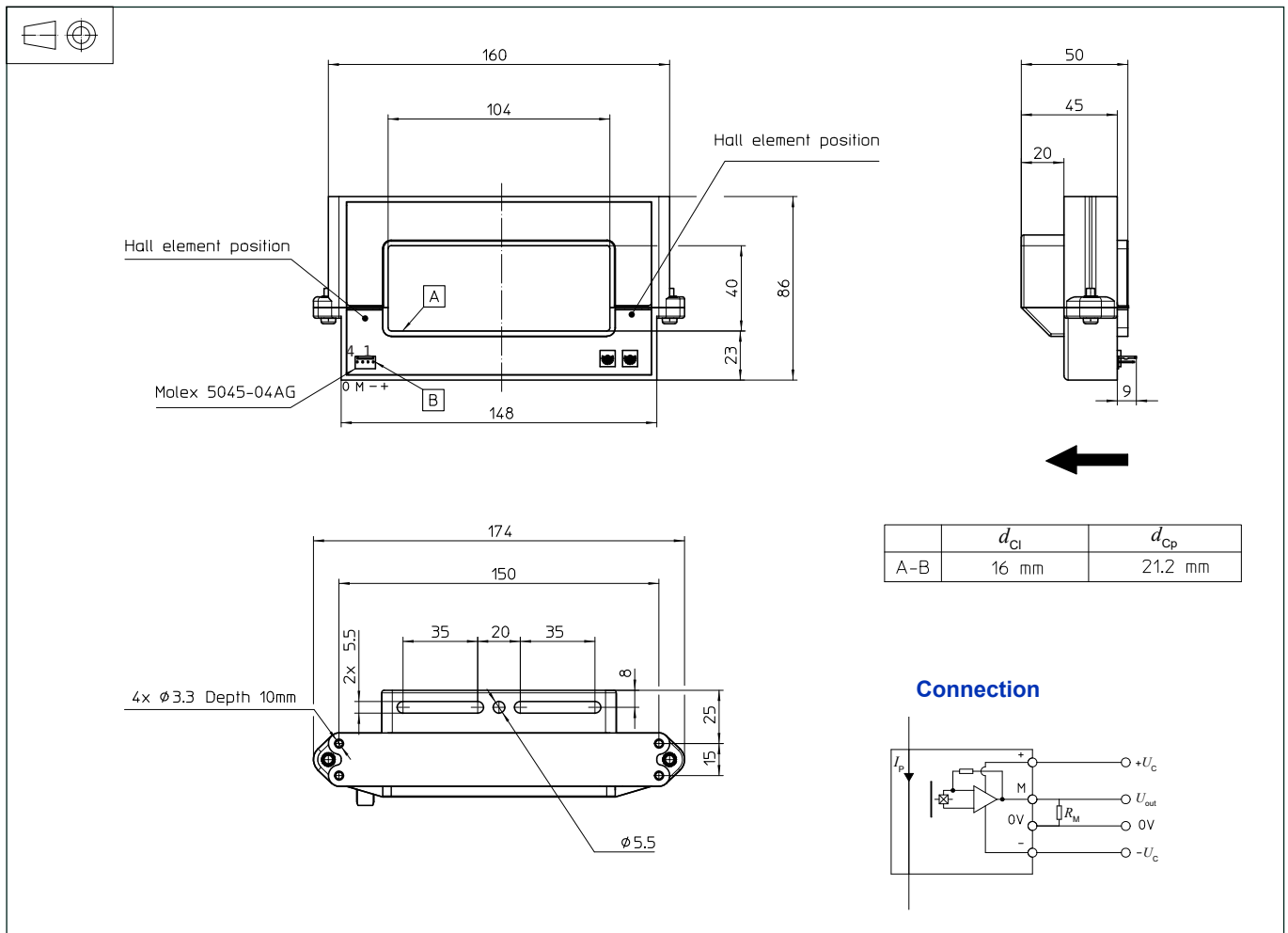

Mechanical characteristics

- General tolerance ± 1 mm
- Primary through hole 104×40 mm
- Busbar fastening or panel mounting 1 hole $\phi 5.5$ mm and 2 slots 5.5×35 mm
- Recommended fastening torque 2.4 N·m
- Panel mounting 4 x holes 3.3 mm
- Recommended fastening torque 1 N·m
- Distance between holes axes 15×150 mm
- Secondary connection Molex 5045-04AG
"Malting connector provided with the transducer"

Remarks

- U_{out} is positive when I_p flows in the direction of the arrow.
- The return busbar and primary conductor elbow must be located at least at $2.5 \times$ window length more far away from the transducer case.
- Temperature of the primary conductor should not exceed 100°C .
- Installation of the transducer must be done unless otherwise specified on the datasheet, according to LEM Transducer Generic Mounting Rules. Please refer to LEM document N°ANE120504 available on our Web site: <https://www.lem.com/en/file/3137/download/>.
- Dynamic performances are best with a single busbar completely filling the primary hole.
- This is a standard model. For different versions (supply voltages, turns ratios, unidirectional measurements...), please contact us.

单击下面可查看定价，库存，交付和生命周期等信息

[>>LEM\(莱姆\)](#)