

AUTOMOTIVE CURRENT TRANSDUCER OPEN LOOP TECHNOLOGY

HAH3DR 900-S00/SP4

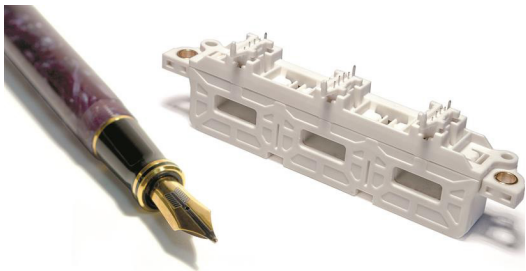

Introduction

The HAH3DR-S00 family is a tri-phase transducer for DC, AC, or pulsed currents measurement in high power and low voltage automotive applications. It offers a galvanic separation between the primary circuit (high power) and the secondary circuit (electronic circuit).

The HAH3DR-S00 family gives you a choice of having different current measuring ranges in the same housing (from ± 100 up to ± 900 A).

Features

- Open Loop transducer using the Hall effect sensor
- PCB mounting
- Low voltage application
- Unipolar +5 V DC power supply
- Primary current measuring range up to ± 900 A
- Maximum RMS primary admissible current: limited by the busbar, the magnetic core or ASIC $T < +150$ °C
- Operating temperature range: -40 °C $< T < +125$ °C
- Output voltage: fully ratio-metric (in sensitivity and offset).

Special feature

- Tri-phase transducer.

Advantages

- Excellent accuracy
- Very good linearity
- Very low thermal offset drift
- Very low thermal sensitivity drift
- Wide frequency bandwidth
- No insertion losses
- Very fast response time.

Automotive applications

- Starter Generators
- Inverters
- HEV applications
- EV applications
- DC / DC converter.

Principle of HAH3DR S00 family

The open loop transducers uses a Hall effect integrated circuit. The magnetic flux density B , contributing to the rise of the Hall voltage, is generated by the primary current I_p to be measured.

The current to be measured I_p is supplied by a current source i.e. battery or generator (Figure 1).

Within the linear region of the hysteresis cycle, B is proportional to:

$$B(I_p) = a \times I_p$$

The Hall voltage is thus expressed by:

$$V_H = (c_H / d) \times I_H \times a \times I_p$$

Except for I_p , all terms of this equation are constant. Therefore:

$$V_H = b \times I_p$$

a constant

b constant

c_H Hall coefficient

d thickness of the Hall plate

I_H current across the Hall plates

The measurement signal V_H amplified to supply the user output voltage or current.

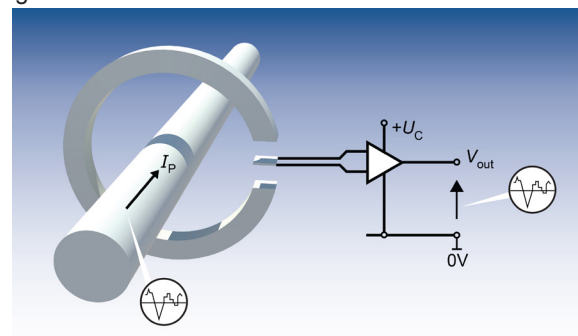
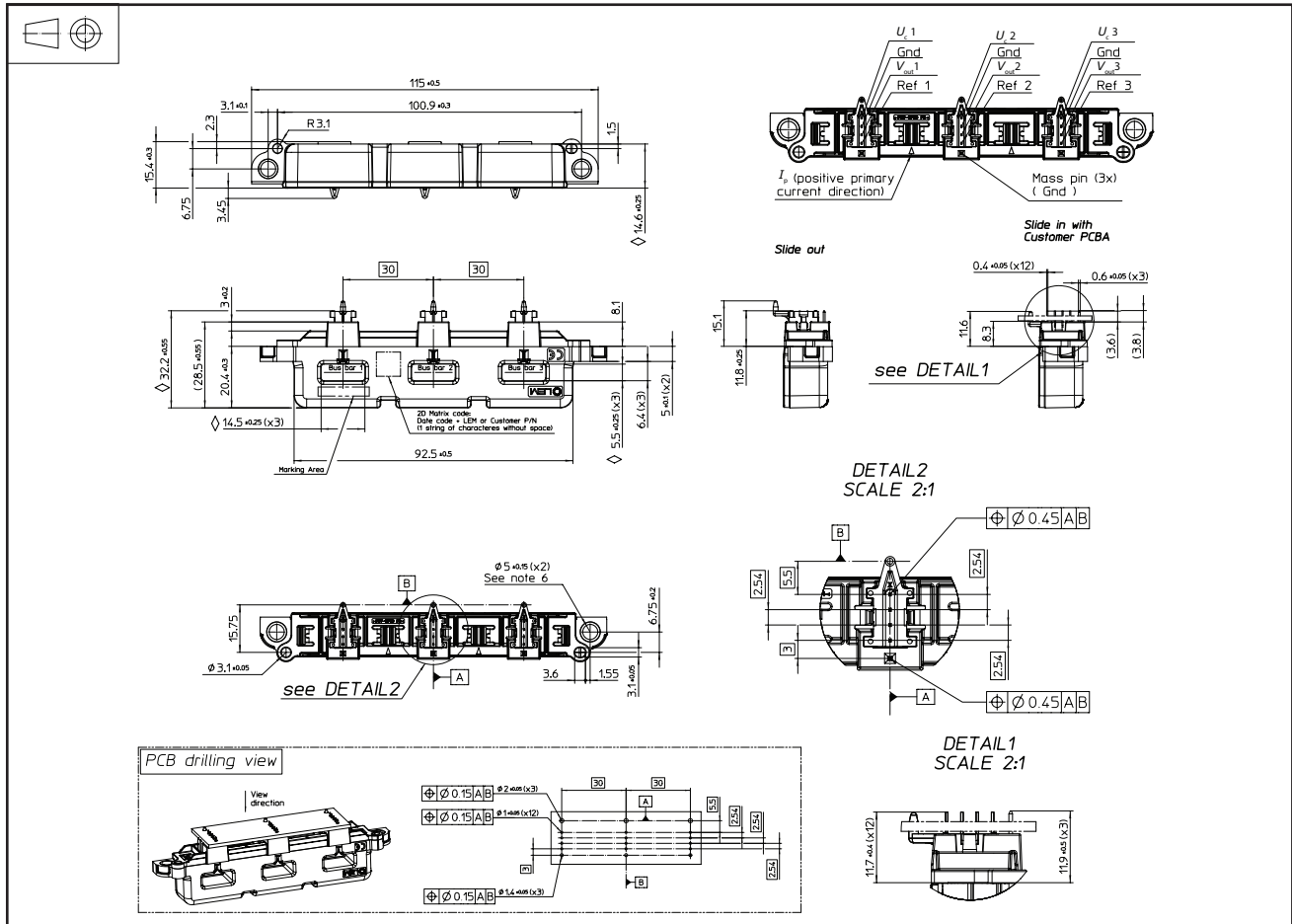

Fig. 1: Principle of the open loop transducer.

Dimensions (in mm)



Mechanical characteristics

- Plastic case >PBT-GF30< (Natural)
- Magnetic core FeSi wound core
- Mass 82 g ± 5 %
- Degrees of protection provided by enclosure (IP4x)

Mounting recommendation

- Assembly torque max 1.5 N·m ± 10 %
- Soldering type See page 7

Remark

- $V_{out} > V_o$ when I_p flows in the positive direction (see arrow on drawing).

$R_L > 10$ kΩ optional resistor for signal line diagnostic
 C_L 4 nF < C_L < 18 nF EMC protection
 Normal value is 4.7 nF
 Mandatory to stabilize the output signal.

Capacitor V_{ref} / Gnd 4.7 nF
 Capacitor U_c / Gnd 47 nF

System architecture (example)

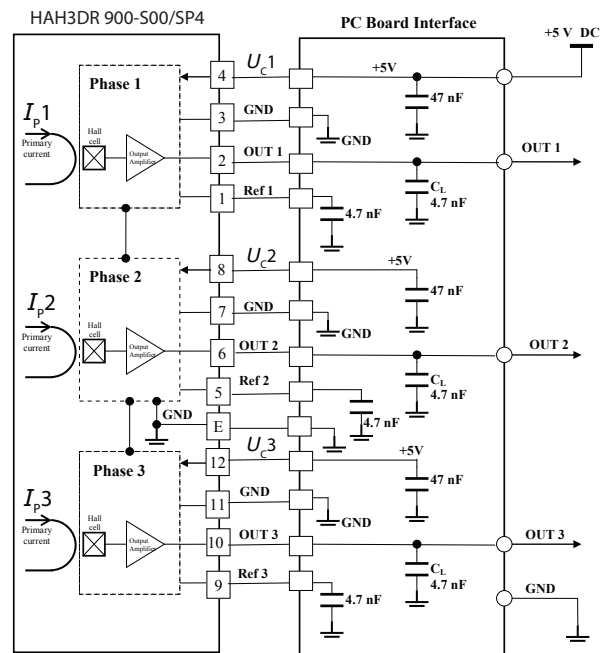

Absolute ratings (not operating)

Parameter	Symbol	Unit	Specification			Conditions
			Min	Typical	Max	
Maximum supply voltage	U_{Cmax}	V	-0.5		8	Continuous, not operating
					6.5	Exceeding this voltage may temporarily reconfigure the circuit until the next power-on
Output voltage low ¹⁾	V_{outL}				0.2	@ $U_C = 5V, T_A = 25^\circ C$
Output voltage high ¹⁾	V_{outH}		4.8			
Ambient storage temperature	T_S	°C	-50		125	
Electrostatic discharge voltage (HBM)	U_{ESD}	kV			2	JESD22-A114-B class 2
RMS voltage for AC insulation test	U_d	kV			2.5	50 Hz, 1 min, IEC 60664 part1
Creepage distance	d_{Cp}	mm	4.78			
Clearance	d_{Cl}	mm	3.78			
Comparative tracking index	CTI	V	200			
Insulation resistance	R_{INS}	MΩ	500			500 V DC, ISO 16750
Primary nominal peak current	I_{PN}	A			2)	

Operating characteristics in nominal range (I_{PN})

Parameter	Symbol	Unit	Specification			Conditions
			Min	Typical	Max	
Electrical Data						
Primary current, measuring range	I_{PM}	A	-900		900	
Primary nominal DC or RMS current	I_{PN}	A	-900		900	
Supply voltage ¹⁾	U_C	V	4.75	5	5.25	
Ambient operating temperature	T_A	°C	-40		125	
Capacitive loading	C_L	nF	4	4.7	18	
Output voltage (Analog) ¹⁾	V_{out}	V	$V_{out} = (U_C/5) \times (V_o + G \times I_p)$			@ U_C
Offset voltage	V_o	V		2.5		@ $U_C = 5V$
Sensitivity ¹⁾	G	mV/A		2.22		@ $U_C = 5V$
Current consumption (for 3 phases)	I_C	mA		45	60	@ $U_C = 5V, @ -40^\circ C < T_A < 125^\circ C$
Load resistance	R_L	kΩ	10			
Output internal resistance	R_{out}	Ω			10	DC to 1 KHz
Performance Data						
Ratiometricity error	ϵ_r	%		0.5		
Sensitivity error	ϵ_G	%		±0.5		@ $T_A = 25^\circ C, @ U_C = 5V$
				±1		@ $T_A = 25^\circ C, \text{After } T \text{ Cycles}, @ U_C = 5V$
Electrical offset voltage	V_{OE}	mV		±4		@ $T_A = 25^\circ C, @ U_C = 5V$
Magnetic offset voltage	V_{OM}	mV	-7.5		7.5	@ $T_A = 25^\circ C, @ U_C = 5V$
Average temperature coefficient of V_{OE}	TCV_{OEAV}	mV/°C	-0.08		0.08	@ $-40^\circ C < T_A < 125^\circ C$
Average temperature coefficient of G	TCG_{AV}	%/°C	-0.03	±0.01	0.03	@ $-40^\circ C < T_A < 125^\circ C$
Linearity error	ϵ_L	% I_p	-1		1	@ $U_C = 5V, @ T_A = 25^\circ C, @ I = I_{PM}$
Step response time to 90 % I_{PN}	t_r	μs		4	6	$di/dt = 100A/\mu s$
Frequency bandwidth ²⁾	BW	kHz	40			@ -3 dB
Peak-to-peak noise voltage	$V_{no pp}$	mV			10	@ DC to 1 MHz
Phase shift	$\Delta\phi$	°	-4		0	@ DC to 1 KHz

Notes: ¹⁾ The output voltage V_{out} , the offset voltage V_o , the sensitivity G and the output voltage low/high $V_{outL/H}$ are fully ratiometric and dependant of the supply voltage U_C according the the following formula:

$$I_p = \left(\frac{5}{U_C} \times V_{out} - V_o \right) \times \frac{1}{G} \text{ with } G \text{ in (V/A)}$$

- ²⁾ Primary current frequencies must be limited in order to avoid excessive heating of the busbar, magnetic core and the ASIC (see feature paragraph in page 1/7)
- ³⁾ Transducer is not protected against reverse polarity.

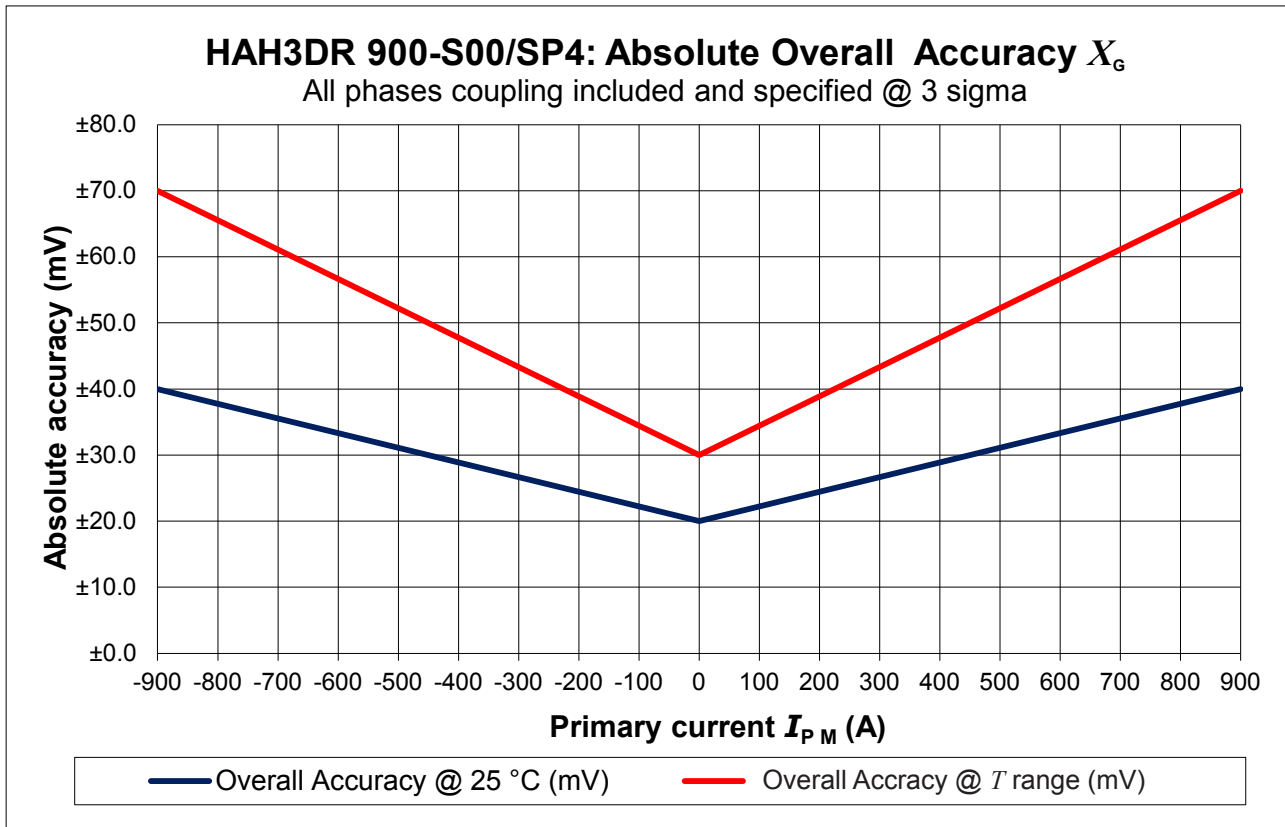
Accuracy

I_p (A)	Accuracy @ 25 °C (mV)	Accuracy @ T range (mV)
-900	±40	±70
0	±20	±30
900	±40	±70

PERFORMANCES PARAMETERS DEFINITIONS

Primary current definition:

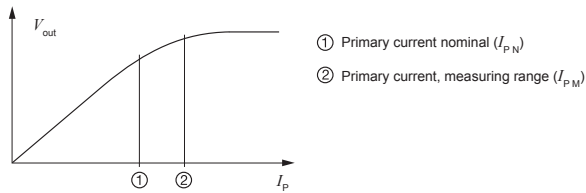

Definition of typical, minimum and maximum values:

Minimum and maximum values for specified limiting and safety conditions have to be understood as such as values shown in "typical" graphs. On the other hand, measured values are part of a statistical distribution that can be specified by an interval with upper and lower limits and a probability for measured values to lie within this interval. Unless otherwise stated (e.g. "100 % tested"), the LEM definition for such intervals designated with "min" and "max" is that the probability for values of samples to lie in this interval is 99.73 %. For a normal (Gaussian) distribution, this corresponds to an interval between -3 sigma and $+3$ sigma. If "typical" values are not obviously mean or average values, those values are defined to delimit intervals with a probability of 68.27 %, corresponding to an interval between $-\text{sigma}$ and $+\text{sigma}$ for a normal distribution. Typical, minimum and maximum values are determined during the initial characterization of a product.

Output noise voltage:

The output voltage noise is the result of the noise floor of the Hall elements and the linear amplifier.

Magnetic offset:

The magnetic offset is the consequence of an any current on the primary side. It's defined after a stated excursion of primary current.

Linearity:

The maximum positive or negative discrepancy with a reference straight line $V_{out} = f(I_p)$.

Unit: linearity (%) expressed with full scale of $I_{p,N}$.

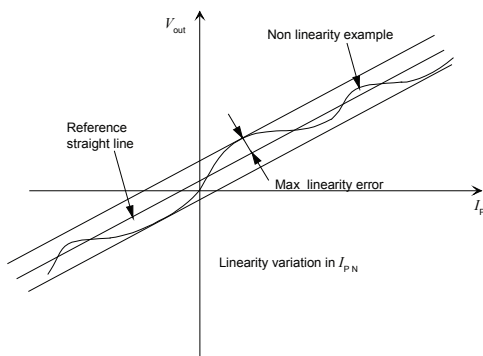

Response time (delay time) t_r :

The time between the primary current signal ($I_{p,N}$) and the output signal reach at 90 % of its final value.

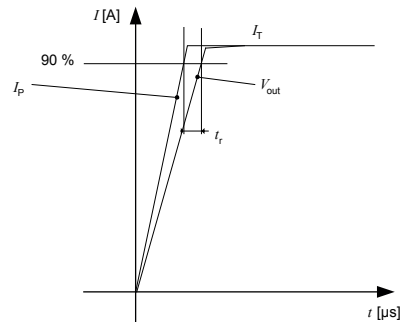

Sensitivity:

The transducer's sensitivity G is the slope of the straight line

$V_{out} = f(I_p)$, it must establish the relation:

$$V_{out}(I_p) = U_C/5 (G \times I_p + V_O)$$

Offset with temperature:

The error of the offset in the operating temperature is the variation of the offset in the temperature considered with the initial offset at 25 °C.

The offset variation $I_{O,T}$ is a maximum variation the offset in the temperature range:

$$I_{O,T} = I_{O,E} \max - I_{O,E} \min$$

The offset drift $TCI_{O,E,AV}$ is the $I_{O,T}$ value divided by the temperature range.

Sensitivity with temperature:

The error of the sensitivity in the operating temperature is the relative variation of sensitivity with the temperature considered with the initial offset at 25 °C.

The sensitivity variation G_T is the maximum variation (in ppm or %) of the sensitivity in the temperature range:

$G_T = (\text{Sensitivity max} - \text{Sensitivity min}) / \text{Sensitivity at } 25 \text{ }^\circ\text{C}$.

The sensitivity drift TCG_{AV} is the G_T value divided by the temperature range. Deeper and detailed info available is our LEM technical sales offices (www.lem.com).

Offset voltage @ $I_p = 0$ A:

The offset voltage is the output voltage when the primary current is zero. The ideal value of V_O is $U_C/2$. So, the difference of $V_O - U_C/2$ is called the total offset voltage error. This offset error can be attributed to the electrical offset (due to the resolution of the ASIC quiescent voltage trimming), the magnetic offset, the thermal drift and the thermal hysteresis. Deeper and detailed info available is our LEM technical sales offices (www.lem.com).

Environmental test specifications:

Refer to LEM GROUP test plan laboratory CO.11.11.515.0 with "Tracking_Test Plan_Auto" sheet.

Environmental test specifications:

Name	Standard	Conditions
Electrical tests		
Phase delay check	LEM Procedure	100 Hz to 10 kHz
Noise measurement	LEM Procedure	Sweep from DC to 1 MHz
Response time di/dr	LEM Procedure	100 A/ μ s I pulse = 900 A
dV/dr	LEM Procedure	2000 V/ μ s V = 2000 V
Dielectric Withstand Voltage test		2500 VAC / 1 min / 50 Hz
Insulation resistance	ISO 16750-2 (2010)	500 V DC, time = 60 s $R_{INS} \geq 500$ M Ω Minimum
Environmental tests		
High T °C, High Humidity, Electrical connection	IEC 60068-2-78 (2001)	1364 hours +85 °C / 85 % RH, $I_p = 0$
Thermal Cycle Test (Simplified profile)	IEC 60068-2-14, Test Nb	1000 cycles (2000 h), Slope 10 °C / min -40 °C (30') / +25 °C (15') / +150 °C (30') U_C not connected, $I_p = 0$
Thermal Shock	IEC 60068-2-14 (2009) Test NaTest Na	1000 cycles (1000 h), 30mn ""-40 °C"" // 30 min "" +125 °C"" U_C not connected, $I_p = 0$
Dew Condensation		See below ""Dew condensation"" tab. $I_p = 0$ all test. $U_C = 0$ for 2 h then $U_C = 5$ V for end of test. 2 h ""-5 °C / 0 % HR // 10 mn ""35°C / 85% HR""
High T °C Storage + High T °C Exposure		Storage : 125 °C for 1364 h + Exposure : 150 °C for 1000 h U_C not connected, $I_p = 0$ for both tests
Low T °C Storage.		-50 °C for 1364 h U_C not connected, $I_p = 0$
Temperature / Humidity cyclic test	IEC 60068-2-38 Z/AD (01/2009) ISO 16750-4 § 5.6 (04/2010)	10 cycles of 24 h; Duration = 240 h $U_C = 5$ V ; $I_p = 0$ A; Monitoring offset only Check After stab. @ 25 °C (End test)
Mechanical Shock	IEC 60068-2-27 (2008)	50 g / 5 ms Half Sine @ 25 °C 10 shocks of each direction (Total: 60) U_C not connected, $I_p = 0$
Random Vibration	UAES / BOSCH	Random profile @ 4.5 G and -40 °C to 105 °C -22 h / axes Monitoring during vibration. $U_C = 5$, $I_p = 0$
Sinusoidal Vibration	UAES / BOSCH	Sinusoidal profile @ 3 G and -40 °C to 105 °C -8 h / axes Monitoring during vibration. $U_C = 5$, $I_p = 0$
DUST	ISO20653 - IP 4x	
EMC test		
Radiated Emission Absorber Lined Shielded Enclosure (ALSE)	CISPR 25	0.15 MHz to 2500 MHz Limit: CISPR 25 (ed3.0) Class 5 Peak (table 9)
Radiated Immunity Bulk Current Injection (BCI)	GMW3097 (2006) §3.4.1 ISO 11452-1 & -4	1 MHz to 400 MHz Level: Level 2 (table 11)
Radiated Immunity Anechoic chamber	ISO 11452-1 & -2	80 MHz to 2000 MHz Level: Level 2 (table 12)
ESD Test	ISO 10605	150 pF / 2000 Ω Contact: ± 4 , ± 6 kV Air: ± 8 kV U_C not connected
MECHANICAL tests		
Free Fall (Device not packaged)	IEC 60068-2-31 §5.2: method 1 (05/2008)	Height = 1 m; Concrete floor 3 axis; 2 directions by axis; 1 sample by axis
Package drop	JIS C60068-2-31 : 1995	Drop test on 4 bottom edges, 4 bottom corners, concrete floor. + topple test Measure Before/After test on EOL bench (LEM208)

Soldering recommendations:**1 - Manual Iron Soldering – Automatic Point-to-Point Iron Soldering**

Manual Iron Soldering and Automatic Point-to-Point Iron Soldering methods are allowed for Through Hole applications.

Package body needs to be shield from soldering heat by the PCB.

Customer needs to guarantee and control, through suitable methods, that temperature of the plastic body does not exceed 170 °C. The soldering iron temperature should be set as low as possible (maximum 350 °C) and should not exceed recommended soldering time (maximum 5 seconds).

2 - Reflow

Reflow techniques can be used to solder the sensor. Temperature profile should conform to those describe in Jedec-020 standard. However reflow soldering creates a risk for exposing the plastic body of the Asic to excessive temperatures around and above the TG of the mold compound (Appr. 170 °C). To avoid this, a particular tool (shield) has to be used. For any particular case, the actual temperature of the package body throughout the process shall be verified to meet above restriction prior to starting production.

3 - Wave soldering

Wave soldering is allowed. A pre-heating step is required and should be performed in accordance with international standard recommendations (eg: EN60068-2-20).

During the pre-heat and soldering phase, the temperature of the plastic body shall not exceed 170 °C.

4 - Welding

An alternative method to connect sensor leads to an external lead frame or a wire is welding. As core material of lead is copper, it can be successfully welded to another copper terminal. Welding methods applied shall be focused on having a minimum power dissipation into the copper lead frame of the sensor. A good solder joint has to be achieved with a proper power settings and timing of the welding apparatus. Optimal settings shall be defined experimentally, by parameter variation to meet following criteria:

- Temperature of the plastic body of the hall sensor shall not exceed 140 °C during the process. Measurement to be taken with a thermal probe attached to the body center.
- Lead plating material shall be molten only in the spot of welding. No boiling and spattering of the lead plating material shall occur. It may result in solder balls spreading in the neighboring area, solder bridging of terminals or other parts of the external lead frame.
- No deformation of the core lead material shall be observed at the point of welding.
- No “spring load” shall remain after welding in the sensor leads toward the sensor body.

Resistance welding is not recommended. It requires heating of terminals until the core copper material becomes in a plastic state so that the parts can be forged together. It often results in molten lead plating in a large area even outside of the welded spot, deformation of leads and higher temperature transferred to the body. Mechanical pressure applied between the terminals to weld and while in the same time body or far end of leads hold by a fixture also may result in a “spring loaded” assembly after welding, what creates a risk for bond wire versus package stress at high temperature applications.

LEM recommends a laser spot welding as best method to provide a reliable connection of sensors leads to external lead frame. Laser spot welding is focusing the energy in a small spot 0.4 to 0.8 mm diameter for 10-100 msec. With proper power setting a good quality solder joint can be obtained without excessive heat transfer away from the solder spot. Care has to be taken that the two materials are in direct contact as no additional material is included in the process and even small gap between the lead and external lead frame may create a risk for poor joint or degradation.

单击下面可查看定价，库存，交付和生命周期等信息

[>>LEM\(莱姆\)](#)