

CUSTOMER : \_\_\_\_\_.

DATE : 2018.08.16 .

REV : REV. 2.0 .

# SPECIFICATIONS FOR APPROVAL

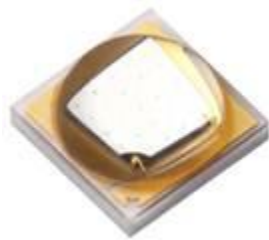



**395nm UV LED PKG**

MODEL NAME : LEUVA33U70UL01



APPROVAL	REMARK	APPENDIX

DESIGNED	CHECKED	APPROVED
2018.08.16	2018.08.16	2018.08.16
S.J.Lee	M.J.Jin	W.J. Kim
		

## TABLE OF CONTENTS

1. Features	-----	2
2. Outline Dimensions	-----	2
3. Applications	-----	3
4. Absolute Maximum Ratings	-----	3
5. Electro-Optical Characteristics	-----	3
6. Bin Structures	-----	4
7. Typical Characteristic Curves	-----	5~6
8. Reliability Test Items and Conditions	-----	7
9. Packing and Labeling of Products	-----	8~11
10. Cautions on Use	-----	12~16
11. Disclaimers	-----	17

## 1. Features

- Lighting Color(Peak Wavelength) : 390~400nm
- Surface Mount Type : 3.40×3.40×2.37 (L×W×H, Unit : mm)
- Viewing Angle(Directivity) : Typical 120°
- Soldering Methods : Reflow Soldering

## 2. Outline Dimensions

(Unit : mm)

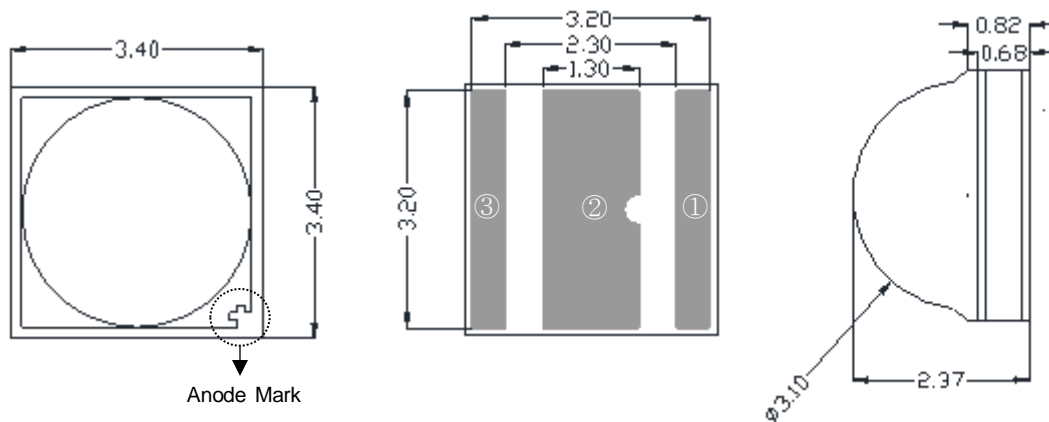

### Recommendable Soldering Pattern (for Reflow Soldering)

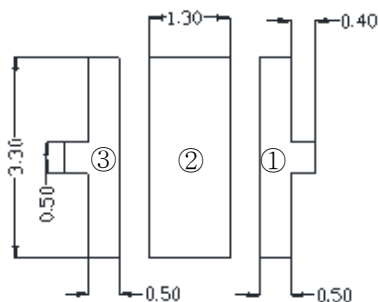
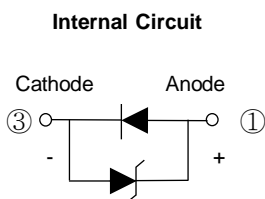

### Pad Configuration

- ① Anode Pad
- ② Thermal Pad
- ③ Cathode Pad

Tolerances unless otherwise mentioned are  $\pm 0.13$  mm

## 3. Applications

- UV Curing, UV Ink Curing, Photo-Catalyst, Sensor Light, etc.

## 4. Absolute Maximum Ratings

(Ta= 25°C)

Items	Symbols	Ratings	Unit
Forward Current	If	700	mA
Power Dissipation	Pd	2.66	W
Operating Temperature	Topr	-10 ~ +85	°C
Storage Temperature	Tstg	-40 ~ +100	°C
Junction Temperature	Tj	<125	°C
Soldering Temperature	JEDEC-J-STD-020D		
ESD Classification	Class 2 (ANSI/ESDA/JEDEC JS-001)		

- ※ Operating the LED beyond the listed maximum ratings may affect device reliability and cause permanent damage. These or any other conditions beyond those indicated under recommended operating conditions are not implied. The exposure to the absolute maximum rated conditions may affect device reliability.
- ※ The LEDs are not designed to be driven in reverse bias

## 5. Electro-Optical Characteristics

(Ta= 25°C)

Items	Symbol	Condition	Target Spec.			Unit	
			Min.	Typ.	Max.		
Forward Voltage	Vf	If = 500 mA	3.2	3.5	3.8	V	
Radiant Flux	Φe		830	1100	1460	mW	
Peak Wavelength	λp		390	395	400	nm	
Spectrum Half Width	Δλ			9.0	-	nm	
Viewing Angle	2Θ1/2			-	130	-	deg
Thermal Resistance <sup>*1)</sup>	Rth j-s			-	4.5	-	°C/W

\*1) Rthj-s = Thermal Resistance (Junction – Solder)

- ※ These values are measured by the LG Innotek optical spectrum analyzer within the following tolerances.
  - Forward Voltage(Vf) : ±0.1V
  - Peak Wavelength(λp) : ±3.0nm
  - Radiant Flux(Φe) : ±10%
- ※ Although all LEDs are tested by LG Innotek equipment, some values may vary slightly depending on the conditions of the test equipment.

## 6. Bin Structures

Items	Rank	Min	Max	Unit
Peak Wavelength	U1	390	395	nm
	U2	395	400	
Radiant Flux	HP15	1330	1460	mW
	HP14	1210	1330	
	HP13	1100	1210	
	HP12	1000	1100	
	HP11	910	1000	
	HP10	830	910	
Forward Voltage	V3	3.6	3.8	V
	V2	3.4	3.6	
	V1	3.2	3.4	
	V0	3.0	3.2	

※ Forward Current = 500mA

※ Rank name method : Please Refer to the Following Example

Rank Name : U1-HP13-V2

- Peak Wavelength = U1
- Radiant Flux = HP13
- Forward Voltage = V2

## 7. Typical Characteristic Curves

■ Forward Voltage vs. Forward Current

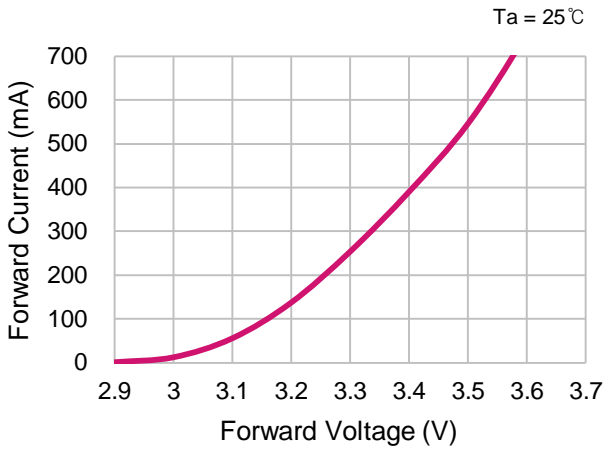

■ Forward Current vs. Relative Radiant Flux

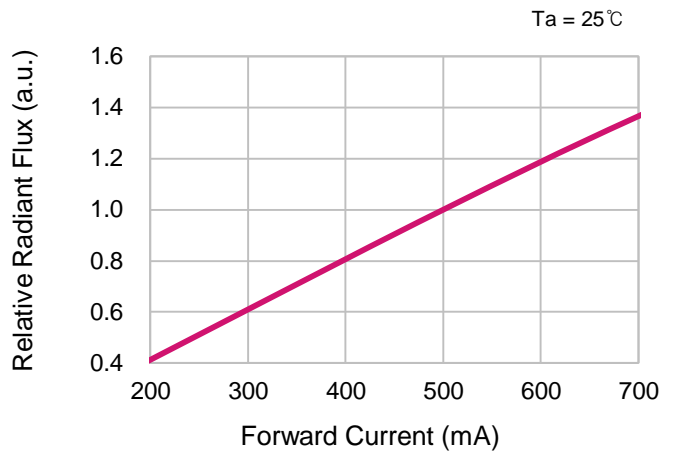

■ Spectrum

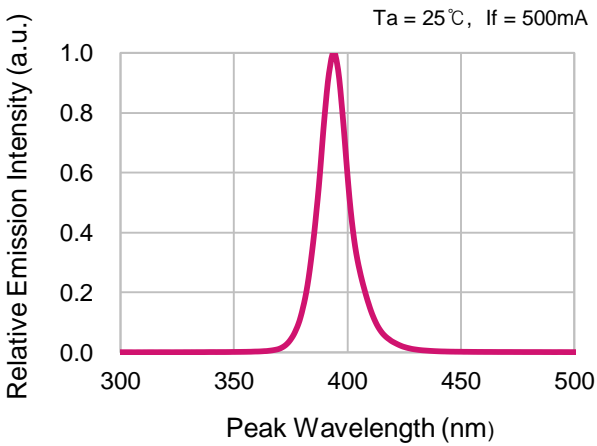

■ Forward Current vs. Peak Wavelength

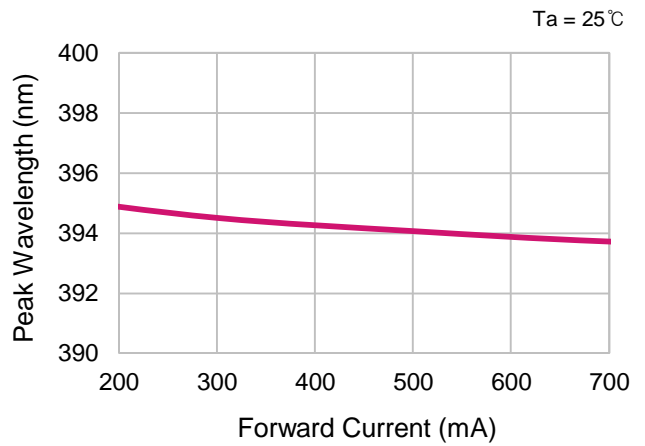

■ Radiation Characteristics

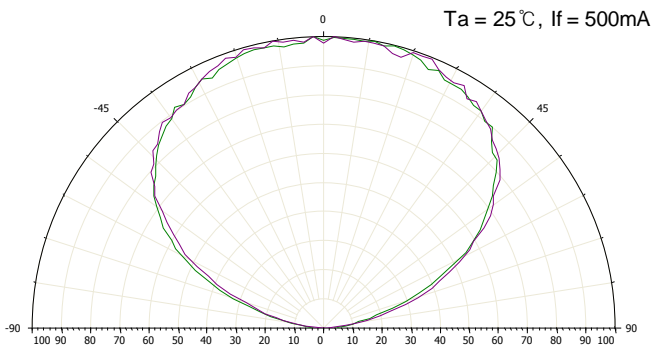

## 7. Typical Characteristic Curves

■ Ambient Temperature vs. Peak Wavelength

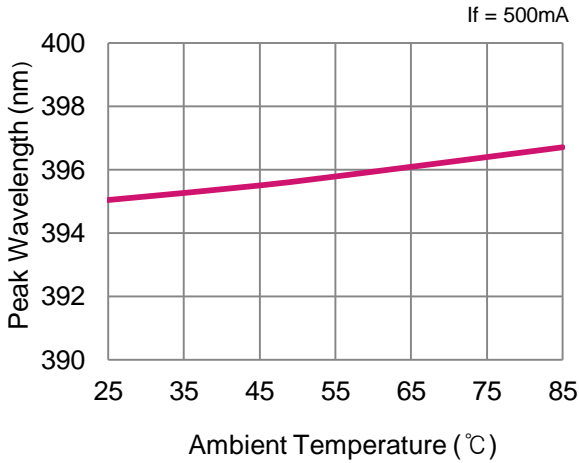

■ Ambient Temperature vs. Relative Radiant Flux

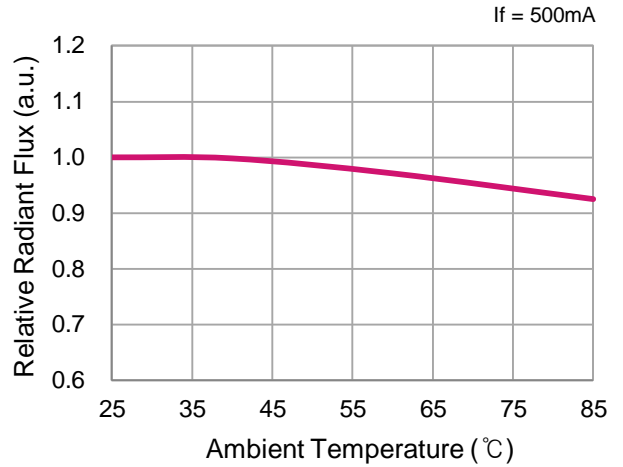

■ Ambient Temperature vs. Forward Voltage

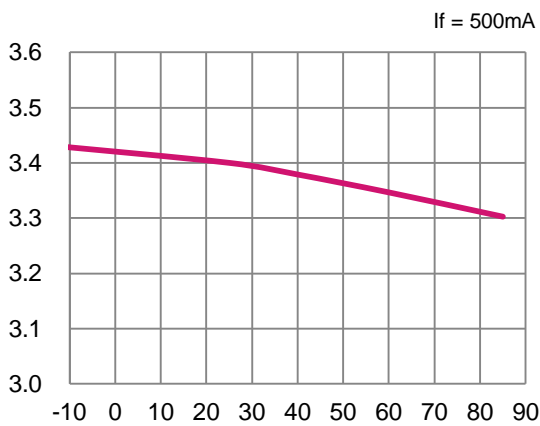

■ Derating Curve

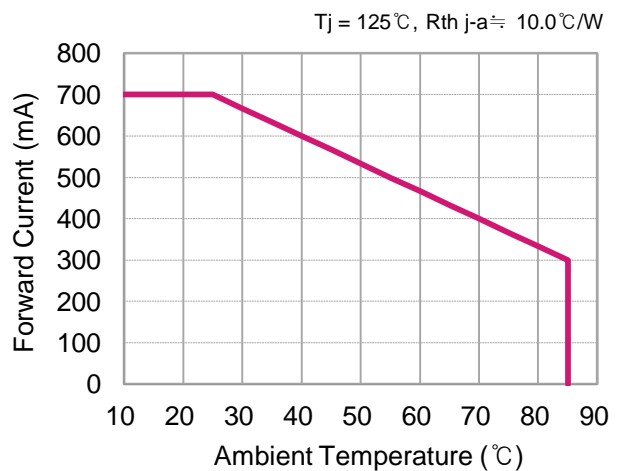

※ The ambient temperature values for each graph are obtained with LG Innotek equipment.

## 8. Reliability Test Items and Conditions

### 8-1. Failure Criteria

Item	Symbol	Test Condition	Criteria	
			Min.	Max.
Forward Voltage	Vf	If = 500mA	-	Initial Value × 1.1
Radiant Flux	Φe	If = 500mA	Initial Value × 0.7	-

### 8-2. Reliability Test

No.	Items	Test Conditions	Test Hours/ Cycles
1	Room Temperature Operating Life (RTOL)	Ta = 25°C, If = 700mA	1,000 Hours
2	High Temperature Operating Life (HTOL)	Ta = 85°C, If = 300mA	1,000 Hours
3	Wet High Temperature Operating Life (WHTOL)	Ta = 60°C, RH = 90%, If = 450mA	500 Hours
4	Low Temperature Operating Life (LTOL)	Ta = -10°C, If = 500mA	1,000 Hours
5	High Temperature Storage Life (HTSL)	Ta = 100°C	1,000 Hours
6	Low Temperature Storage Life (LTSL)	Ta = -40°C	1,000 Hours
7	Temperature Cycle	-40°C (30min) ~ 100°C (30min)	100 Cycles
8	Vibration	100~2000~100Hz Sweep 4min. 200m/s <sup>2</sup> , 3 directions	48 Minutes
9	Electrostatic Discharge	R= 1.5kΩ, C= 100pF, Test Voltage= 2kV , H.B.M.(Human Body Model)	3 Times Negative/ Positive
10	Moisture Sensitivity Level (MSL)	Tsld= 260°C, Pre-condition : 60°C, RH= 60%, 168Hrs	3 Times (Reflows)

\* All Samples are tested using LG Innotek Standard Metal PCB (25x25x1.5 mm<sup>3</sup>(L×W×H)) except MSL test .

\* All samples must pass each test item and all test items must be satisfied.



## 9. Packing and Labeling of Products

### 9-1. Taping Outline Dimensions

#### Reel

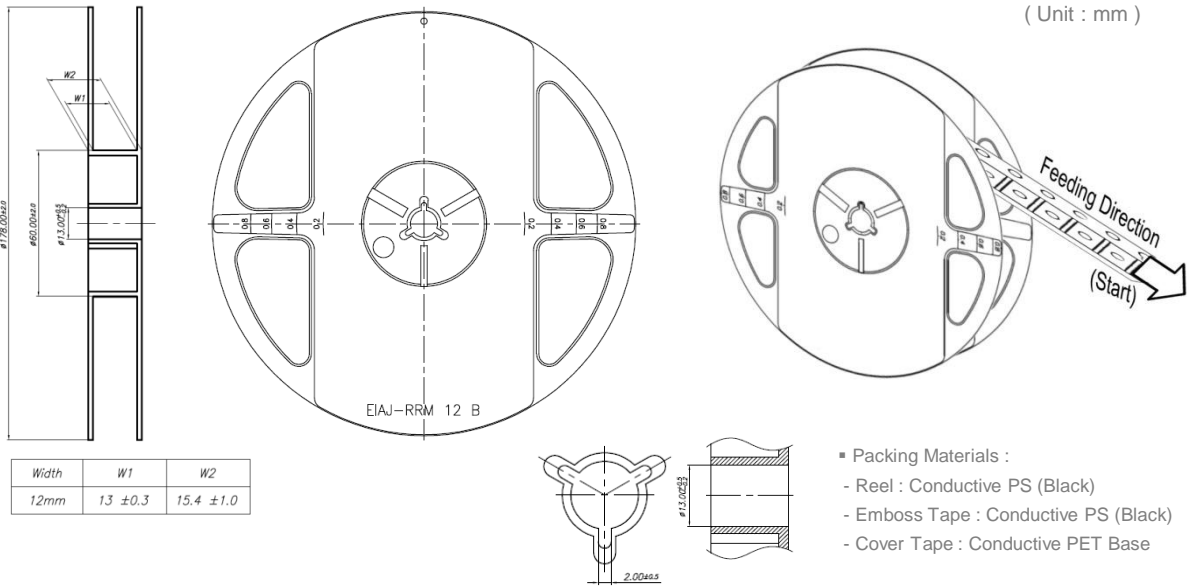

#### Tape

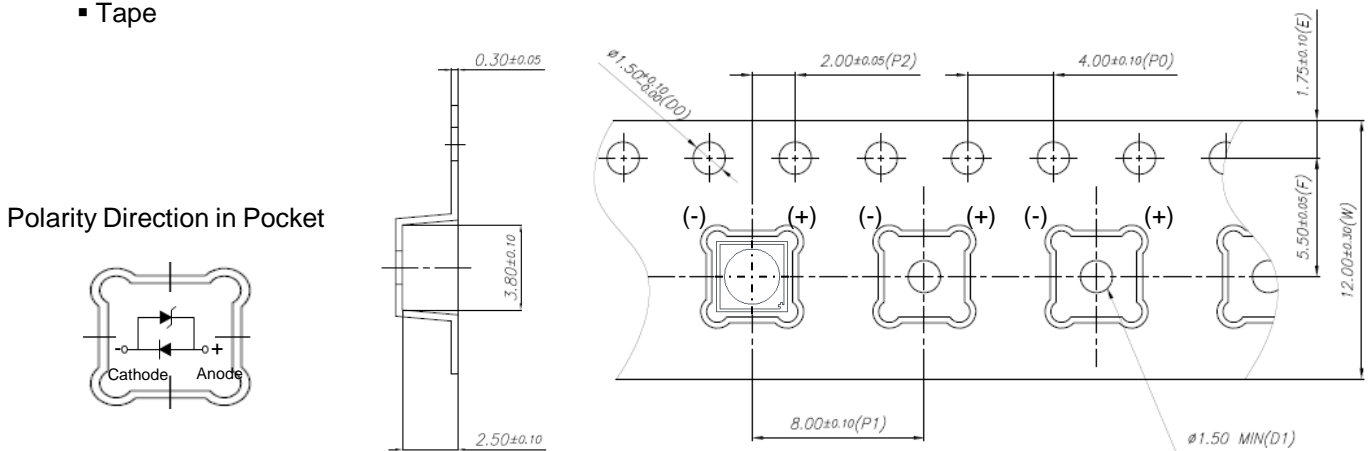

#### Taping Arrangement

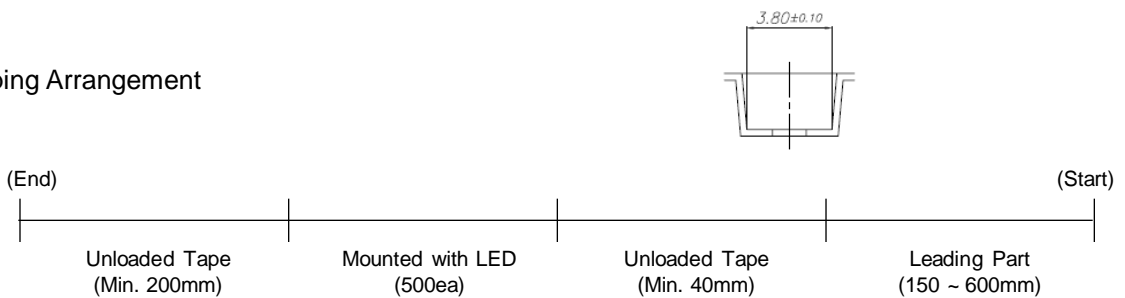

## 9. Packing and Labeling of Products

### 9-2. Package and Label Structure

※. Label A

Specifying Model Name, Rank, Rack, Quantity and Run number

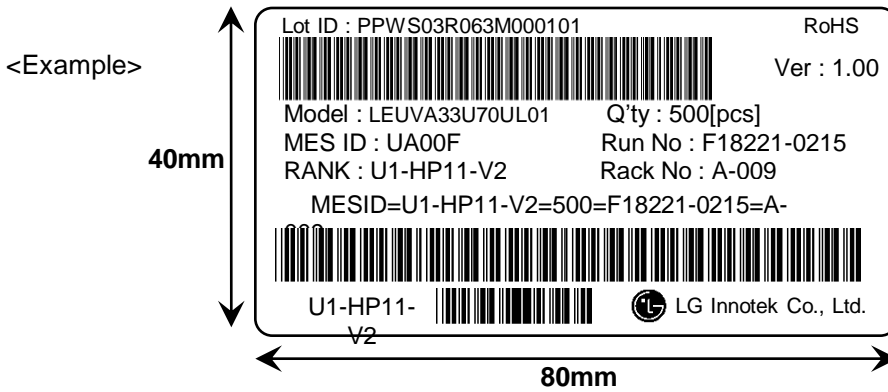

▪ Run No. Indication

1	2	3	4	5	6	—	7	8	9	10
Code	Manufacture Site	Manufacture Year	Manufacture Month	Manufacture date			TP #	Serial No		
	Paju : 1 Huizhou : 9	2016 : 6 2017 : 7 ... 2020 : 0 2021 : 1	1~9 : 1~9 10 : A 11 : B 12 : C	( 01~31)			(00 ~ 99)	(00 ~ ZZ)		

## 9. Packing and Labeling of Products

### 9-2. Package and Label Structure

※ Label B

Specifying Customer, Date, Model Name, Quantity, Customer Part Number, Outbox ID, Rank/Rank Quantity

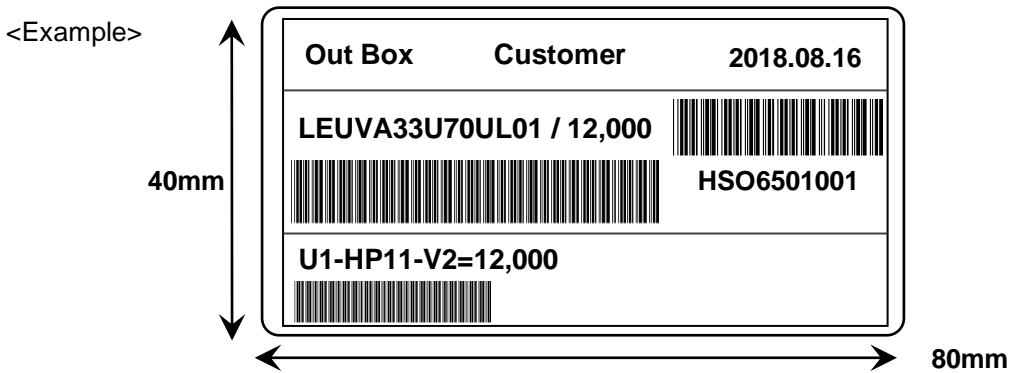

▪ Box ID. Indication

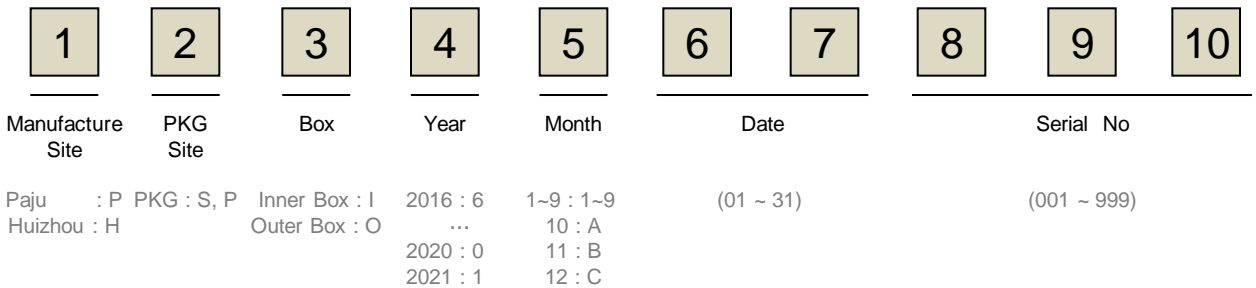

## 9. Packing and Labeling of Products

### 9-3. Packing Specifications

Reeled products (Numbers of products are Max. 500 pcs) packed in a sealed-off and moisture-proof aluminum bag with desiccants (Silica Gel). A Maximum four aluminum bags are packed in an inner box and six inner boxes are packed in an outer box. (Total Max. number of products are 12,000 pcs)

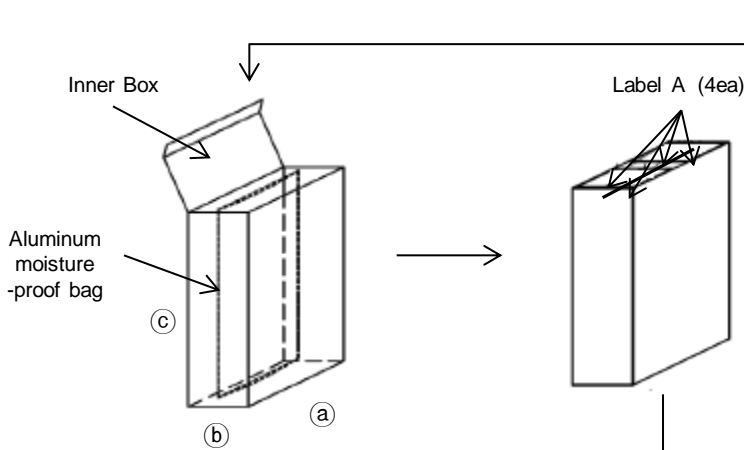
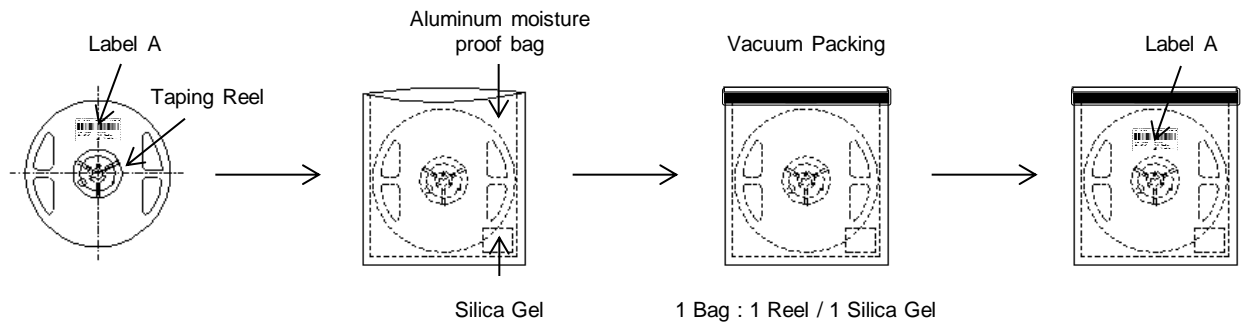

Types	Sizes (mm)		
	(a)	(b)	(c)
Inner Box	227	82	258
Outer Box	530	240	280

Tolerance : ± 10mm

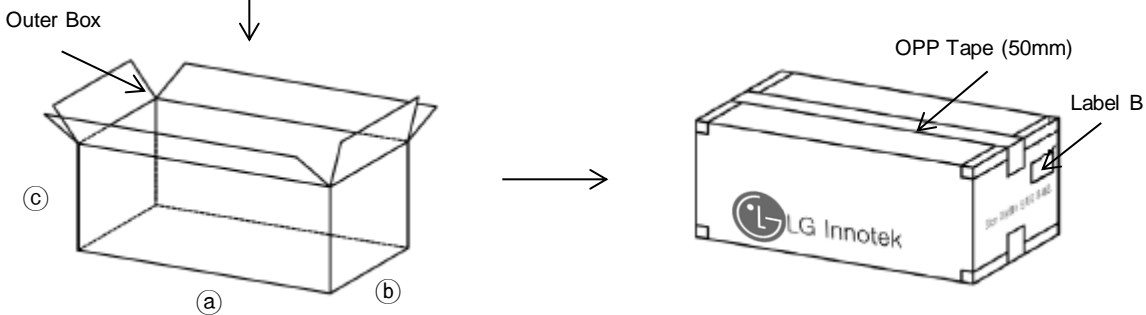

## 10. Cautions on Use

### 10-1. During Usage

- The moisture in the SMD package may vaporize and expand during soldering.
- The moisture can damage the optical and electrical characteristics of the LEDs affecting resin. (Extreme environments such as sudden ambient temperature changes or high humidity that can cause condensation must be avoided.) The LEDs should be necessary to prevent water moisture and salt damage.
- The metal parts(Including silver plated metal) on the LED can rust when exposed to corrosive gases. Therefore, exposure to corrosive gases must be avoided during operation and storage.
- The metal parts(Including silver plated metal) also can be affected not only by the corrosive gases emitted inside of the end-products but by the gases penetrated from outside environment.
- The LED should be avoided direct or indirect (All forms of gas, fume, Vapor form, etc) contact with hazardous materials such as sulfur, chlorine, phthalate, acid, solvent, etc. These materials (S, Cl, VOCs, acid etc.) may cause sulfurization of silver lead-frame or encapsulant silicone discoloration in LED.

VOCs(Volatile Organic Compounds) can be generated from adhesives glue, cleaning flux, molding hardener or organic additive which used in luminaires fixtures and they(VOCs) may cause a significant radiant flux degradation of LED in luminaires when they exposed to heat or light.

To prevent this phenomenon, materials used in luminaires must be carefully selected by users.

### 10-2. During Storage

Conditions		Temperature	Humidity	Time
Storage	Before Opening Aluminum Bag	5°C ~ 30°C	< 50%RH	Within 1 Year from the Delivery Date
	After Opening Aluminum Bag	5°C ~ 30°C	< 60%RH	≤ 672 hours
Baking		65 ± 5°C	< 10%RH	10 ~ 24 hours

- The LEDs should be stored in a clean environment. If the LEDs are stored for 3 months or more after being shipped from LGIT, a sealed container with a nitrogen gas should be used for storage.
- When storing the LEDs after opening aluminum bag, reseal with a moisture absorbent material inside

## 10. Cautions on Use

### 10-3. Cleaning

- Do not use brushes for cleaning or organic solvents (i.e. Acetone, TCE, etc..) for washing as they may damage the resin of the LEDs.
- Isopropyl Alcohol(IPA) solvent is the recommended for cleaning the LEDs under the following conditions.  
Cleaning Condition : IPA, 25°C max. × 60sec max.
- Ultrasonic cleaning is not recommended.
- Excessive N2/air blowing is not advised. Physical stress during blowing can cause the glass to separate from the package.
- Pretests should be conducted with the actual cleaning process to validate that the process will not damage the LEDs.

### 10-4. Thermal Management

- The thermal design of the end product must be seriously considered, particularly at the beginning of the system design process.
- The generation of heat is greatly impacted by the input power, the thermal resistance of the circuit boards and the density of the LED array combined with other components.

### 10-5. Static Electricity

- Wristbands and anti-electrostatic gloves are strongly recommended and all devices, equipment and machinery must be properly grounded when handling the LEDs, which are sensitive against static electricity and surge.
- Precautions are to be taken against surge voltage to the equipment that mounts the LEDs.
- Unusual characteristics such as significant increase of current leakage, decrease of turn-on voltage, or non-operation at a low current can occur when the LED is damaged.

## 10. Cautions on Use

### 10-6. Recommended Circuit

- The current through each LED must not exceed the absolute maximum ratings when designing the circuits.
- In general, there can be various forward voltages for LEDs. Different forward voltages in parallel via a single resistor can result in different forward currents to each LED, which also can output different radiant flux values. In the worst case, the currents can exceed the absolute maximum ratings which can stress the LEDs. Matrix circuit with a single resistor for each LED is recommended to avoid the radiant flux fluctuations.

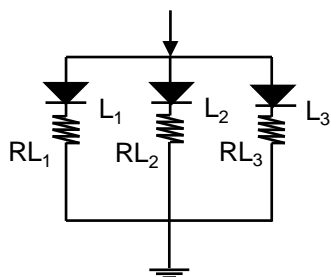

Fig.1 Recommended Circuit in Parallel Mode  
: Separate resistors must be used for each LED.

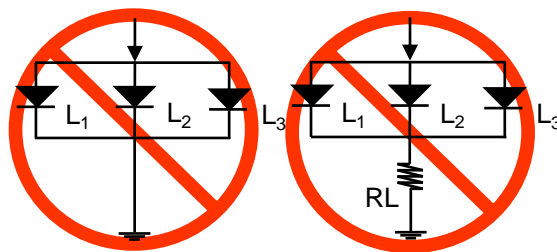

Fig.2 Abnormal Circuit  
Circuits to Avoid : The current through the LEDs may vary due to the variation in LED forward voltage.

- The driving circuits must be designed and operated by forward bias only so that the LEDs are not to be operated by the reverse voltages while turned off, which can damage the LEDs.
- Reverse voltage can damage the zener diode and cause destructions.

## 10. Cautions on Use

### 10-7. Soldering Conditions

- Reflow soldering is the recommended method for assembling LEDs on a circuit board.
- LG Innotek does not guarantee the performance of the LEDs assembled by the dip soldering method.
- Recommended Soldering Profile (according to JEDEC J-STD-020D)

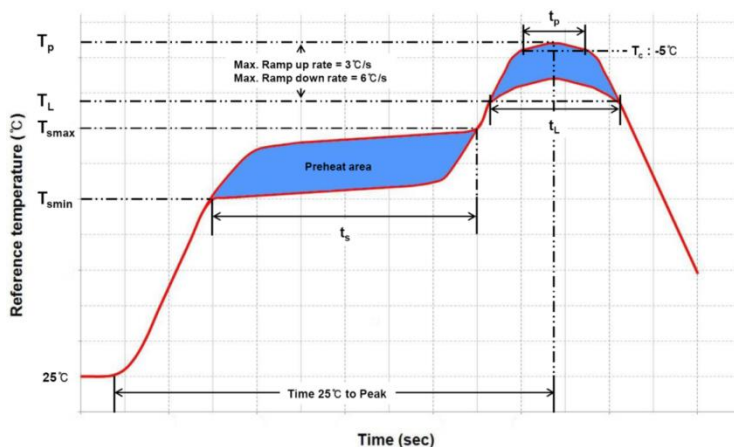

Profile Feature	Pb-Free Assembly	Pb-Based Assembly
Preheat / Soak		
Temperature Min ( $T_{smin}$ )	150°C	100°C
Temperature Max ( $T_{smax}$ )	200°C	150°C
Maximum time( $t_s$ ) from $T_{smin}$ to $T_{smax}$	60~120 seconds	60~120 seconds
Ramp-up rate ( $T_L$ to $T_p$ )	3°C/ second max.	3°C/ second max.
Liquidus temperature ( $T_L$ )	217°C	183°C
Time ( $t_L$ ) maintained above $T_L$	60~150 seconds	60~150 seconds
Maximum peak package body temperature ( $T_p$ )	260°C	235°C
Time( $t_p$ ) within 5°C of the specified temperature ( $T_c$ )	30 seconds	20 seconds
Ramp-down rate ( $T_p$ to $T_L$ )	6°C/second max.	6°C/second max.
Maximum Time 25°C to peak temperature	8 minutes max.	6 minutes max.

- Reflow or hand soldering at the lowest possible temperature is desirable for the LEDs although the recommended soldering conditions are specified in the above diagrams.
- A rapid-rate process is not recommended for cooling the LEDs down from the peak temperature.
- Occasionally there is a brightness decrease caused by the influence of heat of ambient atmosphere during air reflow. It is recommended that the customer use the nitrogen reflow method.
- Glass plate is hermetic sealed on the LEDs.  
Therefore, the LEDs have a soft and very fragile surface on the top of the package.  
The pressure to the surface will be influence to the reliability of the LEDs.  
Precautions should be taken to avoid strong pressure on the silicone resin when leveraging the pick and place machines.
- Reflow soldering should not be done more than two times.



## 10. Cautions on Use

### 10-8. Soldering Iron

- The recommended condition is less than 5 seconds at 260°C.
- The time must be shorter for higher temperatures. (+10°C → -1sec).
- The power dissipation of the soldering iron should be lower than 15W and the surface temperature of the device should be controlled at or under 230°C.

### 10-9. Eye Safety Guidelines

- Do not view directly in to the UV light of LED driven at low current or the LED with optical instruments for measuring such as radiant flux, light distribution and spectrum, etc.
- Do not expose to the human body and eyes during the LED light emitting because UV light can be hazardous for human.
- Please wear UV protective products such as UV protective glasses, mask, etc.

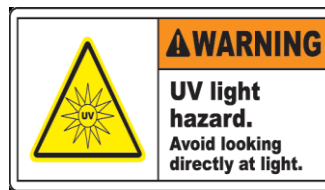
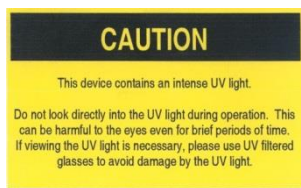

### 10-10. Manual Handling

- During assembly processing, a mechanical stress on the surface should be minimized as much as possible. Our product consists of Aluminum material and glass, etc. (Teflon coated tweezers would be recommended to prevent any scratches on LED package.)
- Glass can be cut, chipped, delaminate or deformed, causing wire-bonding, chip or frame failures if not handled properly.

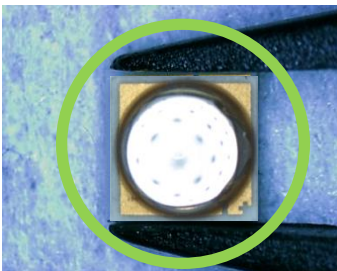

- During SMT processing, there are basically no restrictions regarding the design of the pick-and-place nozzles and tweezers, except that overloaded mechanical pressure on the LED package must be prevented. Also, Do not drop the LED Product.

## 10. Cautions on Use

### 10-11. Others

- LG Innotek will not be held responsible for any damage to the user that may result from accidents, including, without limitation, (i) operation of the user's unit that exceed the absolute maximum rations and/or (ii) not complying with various matters, precautions, or guidelines that demand special attention.
- When defective LEDs are found, the customer shall inform LG Innotek. The customer shall not reverse engineer by disassembling or analyzing the LEDs without having prior written consent from LG Innotek.
- The appearance and specification of LEDs may be modified for improvement without notice. However, LG Innotek shall not be responsible for any damage that may result from such improvement.

## 11. Disclaimer

**THE CUSTOMER SHALL AT ITS OWN RISK, COST, AND EXPENSE OBTAIN FROM ANY APPLICABLE INTERNATIONAL STANDARD INSTITUTION, COUNTRY, GOVERMENTAL AUTHORITY OR AGENCY ANY AND ALL APPROVALS, PERMITS, LICENSES, STANDARDS AND/OR OTHER REQUIREMENTS (COLLECTIVELY "APPROVALS') (INCLUDING, WITHOUT LIMITATION, TYPE APPROVAL, ISO, IEC (INCLUDING 62471, 62778), ACGIH AND ICNIRP) ASSOCIATED WITH OR RELATED TO THE DESIGN, MANUFACTURE, USE, SALE, OFFER FOR SALE OR OTHER DISPOSAL OF (i) THE LEDS AND/OR (ii) THE CUSTOMER'S PRODUCTS INCORPORATING THE LEDS ("SUBJECTED PRODUCTS"), WHICH ARE REQUIRED UNDER THE APPLICABLE LAWS, RULES, REGULATIONS, OR ORDERS OF THE COUNTRIES THAT THE SUBJECTED PRODUCTS ARE MANUFACTURED, IMPORTED, USED, SOLD OR DISPOSED OF. LG INNOTEK SHALL NOT BE RESPONSIBLE FOR ANY AND ALL CLAIMS OR ISSUES ARISING OUT OF, RELATING TO, RESULTING FROM OR IN CONNECTION WITH THE CUSTOMER'S BREACH, VIOLATION OR NON-COMPLIANCE OF OBLIGATIONS SET FORTH ABOVE. THE CUSTOMERS SHALL DEFEND, HOLD HARMLESS AND INDEMNIFY, LG INNOTEK, ITS AFFILIATES, VENDORS, SUBCONTRACTORS AND ALL THEIR RESPECTIVE DIRECTORS, OFFICERS, EMPLOYEES, AGENTS, CUSTOMERS AND DISTRIBUTORS FROM AND AGAINST ANY AND ALL CLAIMS, SUITS, ACTIONS, PROCEEDINGS, DAMAGES, LOSSES, LIABILITIES, FINES, PENALTIES, COSTS AND EXPENSES THAT ARE ARISEN OUT OF OR RESULTED FROM (i) FAILURE OR VIOLATION OF OBTAINING THE APPROVALS; (ii) THE CUSTOMER'S MODIFICATIONS OF AND/OR ADDITIONS TO THE SUBJECTED PRODUCTS; (iii) THE CUSTOMER'S MISUSE OR ABUSE OF THE SUBJECTED PRODUCTS; AND/OR (iv) FAILURE OF THE CUSTOMER TO ABIDE BY ALL APPLICABLE LAWS, RULES, REGULATIONS AND/OR ORDERS THAT AFFECT THE SUBJECTED PRODUCTS.**



单击下面可查看定价，库存，交付和生命周期等信息

[>>LG INNOTEK\(乐金伊诺特\)](#)