

General Description

The LTP3559A is a high voltage, low power consumption and high performance LDO. The family uses an advanced CMOS process and a P-MOSFET pass device to achieve fast start-up, with high output voltage accuracy. The LTP3559A is stable with a $1.0\mu\text{F}$ ~ $10\mu\text{F}$ ceramic output capacitor, and uses a precision voltage reference and feedback loop to achieve a worst-case accuracy of 1% over all load, line, process, and temperature variations.

Features

- Wide Input Voltage Range : up to 45V
- Output Current : 350mA
- Standard Fixed Output Voltage Options : 3.3V, 5.0V
- More Output Voltage Options Available on Request
- Low I_Q : 2.6 μA Typically
- Low Dropout Voltage
- Short current protection:150mA
- Excellent Load and Line Transient Response
- Line Regulation : 0.01%/V Typically
- Package: SOT89-3

Order Information

Model	Package	Ordering Number ^{Note1}	Packing Option
LTP3559A	SOT89-3	LTP3559A-33XT4	Tape and Reel, 1000
	SOT89-3	LTP3559A-50XT4	Tape and Reel, 1000
	SOT89-3	LTP3559A-33RXT4	Tape and Reel, 1000
	SOT89-3	LTP3559A-50RXT4	Tape and Reel, 1000

Pin Description

Top View

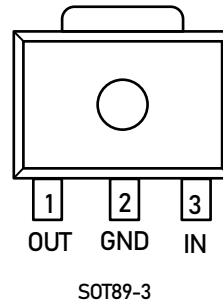
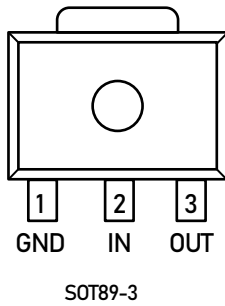

Pin Function

Pin No.		Pin Name	Pin Function
SOT89-3	SOT89-3		
LTP3559A-xxXT4	LTP3559A-xxRXT4		
1	2	GND	Ground.
2	3	IN	Supply input pin.
3	1	OUT	Output pin.

Block Diagram

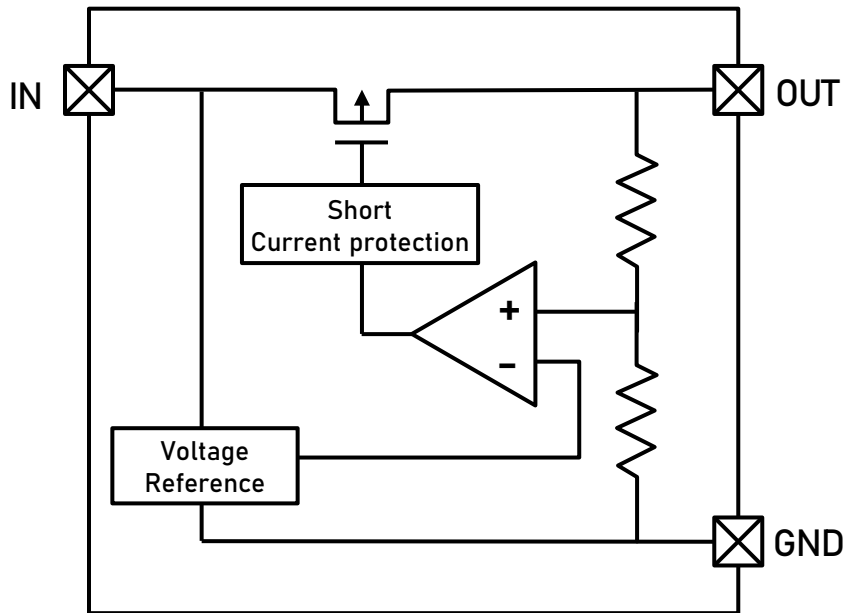

Functional Description

Input Capacitor

A $1\mu\text{F}$ - $10\mu\text{F}$ ceramic capacitor is recommended to connect between V_{IN} and GND pins to decouple input power supply glitch and noise. The amount of the capacitance may be increased without limit. This input capacitor must be located as close as possible to the device to assure input stability and less noise. For PCB layout, a wide copper trace is required for both V_{IN} and GND.

Output Capacitor

An output capacitor is required for the stability of the LDO. The recommended output capacitance is from $1\mu\text{F}$ to $10\mu\text{F}$, Equivalent Series Resistance (ESR) is from $5\text{m}\Omega$ to $100\text{m}\Omega$, and temperature characteristics are X7R or X5R. Higher capacitance values help to improve load/line transient response. The output capacitance may be increased to keep low undershoot/overshoot. Place output capacitor as close as possible to OUT and GND pins.

Low Quiescent Current

The LTP3559A, consuming only around $2.6\mu\text{A}$ for all input range and output loading, provides great power saving in portable and low power applications.

Short Current Limit Protection

When output current at the OUT pin is higher than current limit threshold or the OUT pin is short-circuit to GND, the short current limit protection will be triggered and clamp the output current to approximately 150mA to prevent over-current and to protect the regulator from damage due to overheating.

Absolute Maximum Ratings

Parameter	Rating	Unit
IN pin to GND pin	-0.3 to 48	V
OUT pin to GND pin	-0.3 to 6	V
Thermal Resistance (Junction to Ambient)	135	°C/W
Operating Junction Temperature	-40 to 125	°C
Storage Temperature	-65 to 150	°C
Lead Temperature (Soldering, 10 sec)	300	°C
ESD (HBM mode) ESDA/JEDEC JS-001-2017	±2000V	V

Stresses exceeding those listed in the Maximum Ratings table may damage the device. If any of these limits are exceeded, device functionality should not be assumed, damage may occur and reliability may be affected.

Electrical Characteristics

($V_{IN} = V_{OUT} + 2V$; $I_{OUT} = 10mA$, $C_{IN} = C_{OUT} = 1.0\mu F$, unless otherwise noted. Typical values are at $T_A = +25^\circ C$.)

Symbol	Parameter	Test Conditions	Min	Typ	Max	Unit
V_{IN}	Operating Input Voltage				45	V
V_{OUT}	Regulated Output Voltage	$I_{OUT}=1mA$	V_{OUT} X 0.99		V_{OUT} X 1.01	V
$Line_{REG}$	Line Regulation	$2.5V \leq V_{IN} \leq 36V$, $I_{OUT} = 10mA$		0.01	0.04	%/V
V_{DROP}	Dropout Voltage	$V_{OUT} = 3.3V$, $I_{OUT} = 100mA$ $V_{OUT} = 3.3V$, $I_{OUT} = 200mA$		330 690		mV
$Load_{REG}$	Load Regulation	$1mA \leq I_{OUT} \leq 300mA$, $V_{IN} = V_{OUT} + 2V$			40	mV
I_{OUT}	Maximum Output Current	$V_{IN} = V_{OUT} + 2V$	350			mA
I_Q	Quiescent Current	$I_{OUT} = 0mA$		2.6	4	μA
PSRR	Power Supply Rejection Ratio	$V_{IN} = V_{OUT} + 1V$, $I_{OUT} = 20mA$ $f = 1 kHz$		60		dB
e_N	Output Noise Voltage	$V_{IN} = V_{OUT} + 2V$, $I_{OUT} = 1mA$, $f = 10Hz$ to $100KHz$, ($V_{OUT} = 3.3V$) $C_{OUT} = 1\mu F$		100		μV_{rms}
T_{SD}	Thermal Shutdown Temperature	Temperature Increasing from $T_A = +25^\circ C$		155		$^\circ C$
T_{SDH}	Thermal Shutdown Hysteresis	Temperature Falling From TSD		20		$^\circ C$

TYPICAL PERFORMANCE CHARACTERISTICS

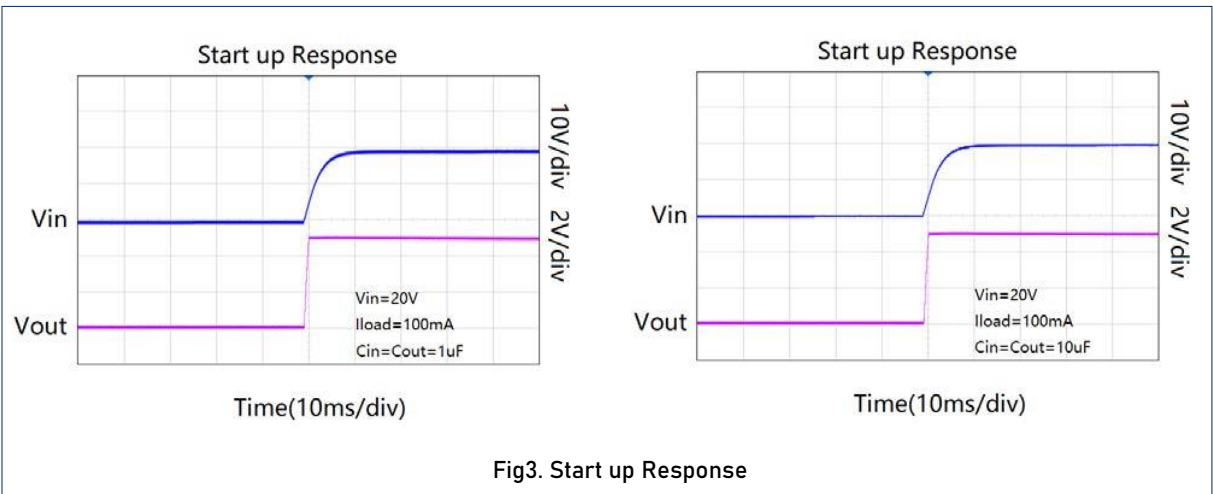
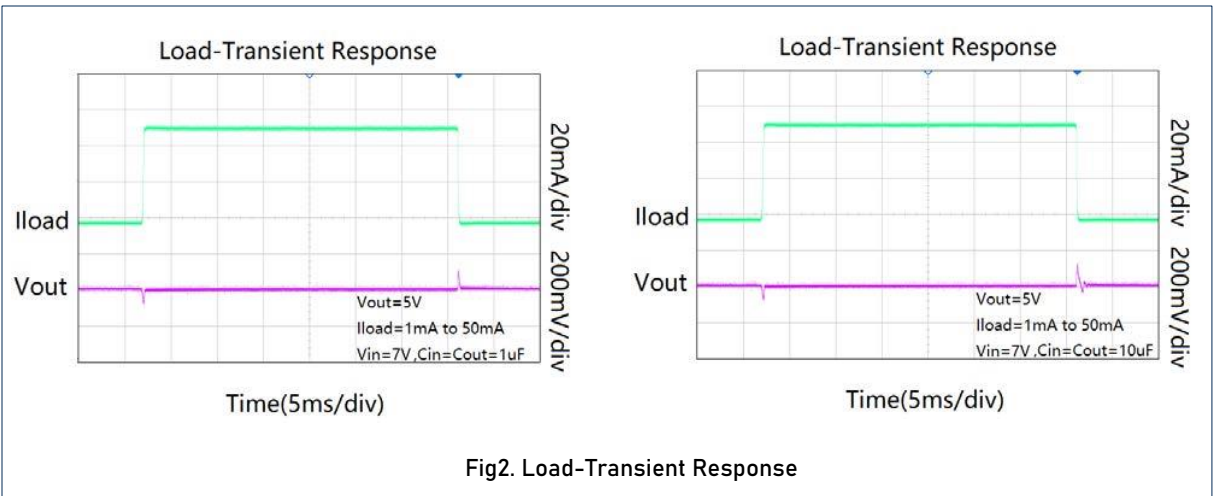
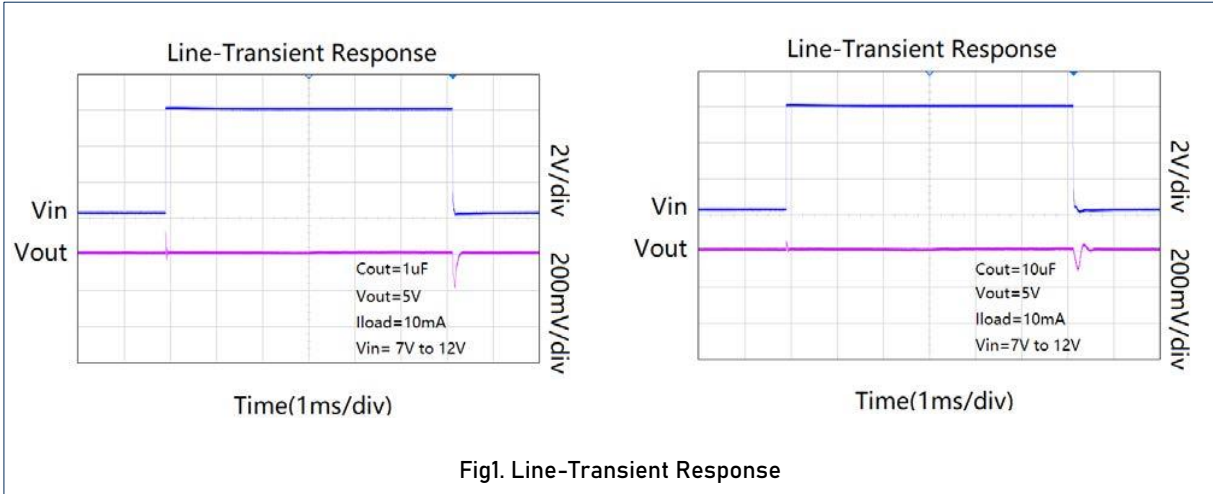

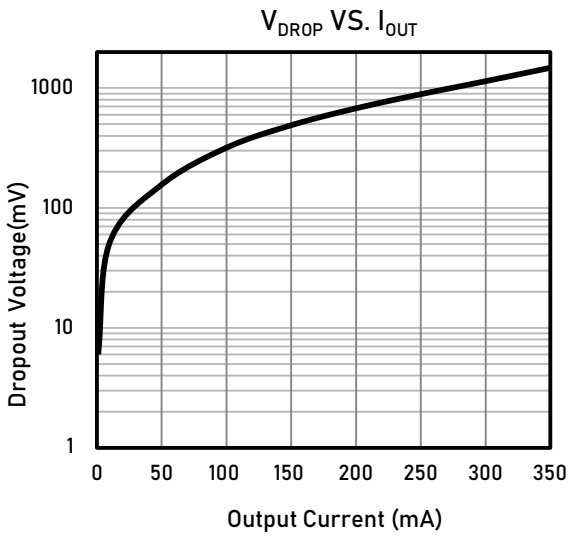

Fig4. Dropout Voltage VS Output Current

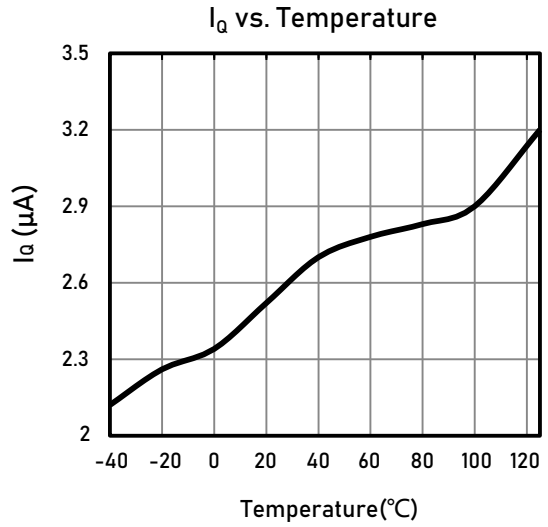
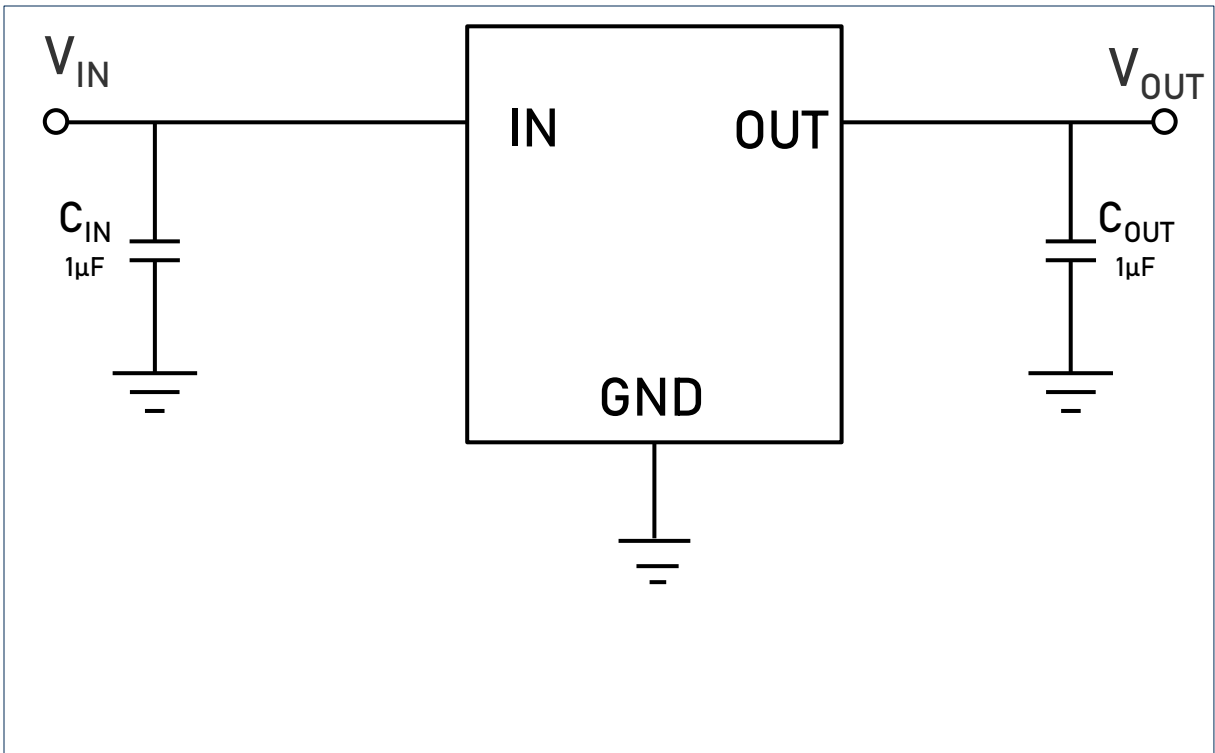

Fig5. I_Q VS Temperature

Application Circuits



CAUTION: These devices are sensitive to electrostatic discharge; follow proper IC Handling Procedures. Linearin and designs are registered trademarks of Linearin Technology Corporation.

© Copyright Linearin Technology Corporation. All Rights Reserved.

All other trademarks mentioned are the property of their respective owners. Downloaded From Oneyac.com

Package Dimension

SOT89-3/ SOT89-3R

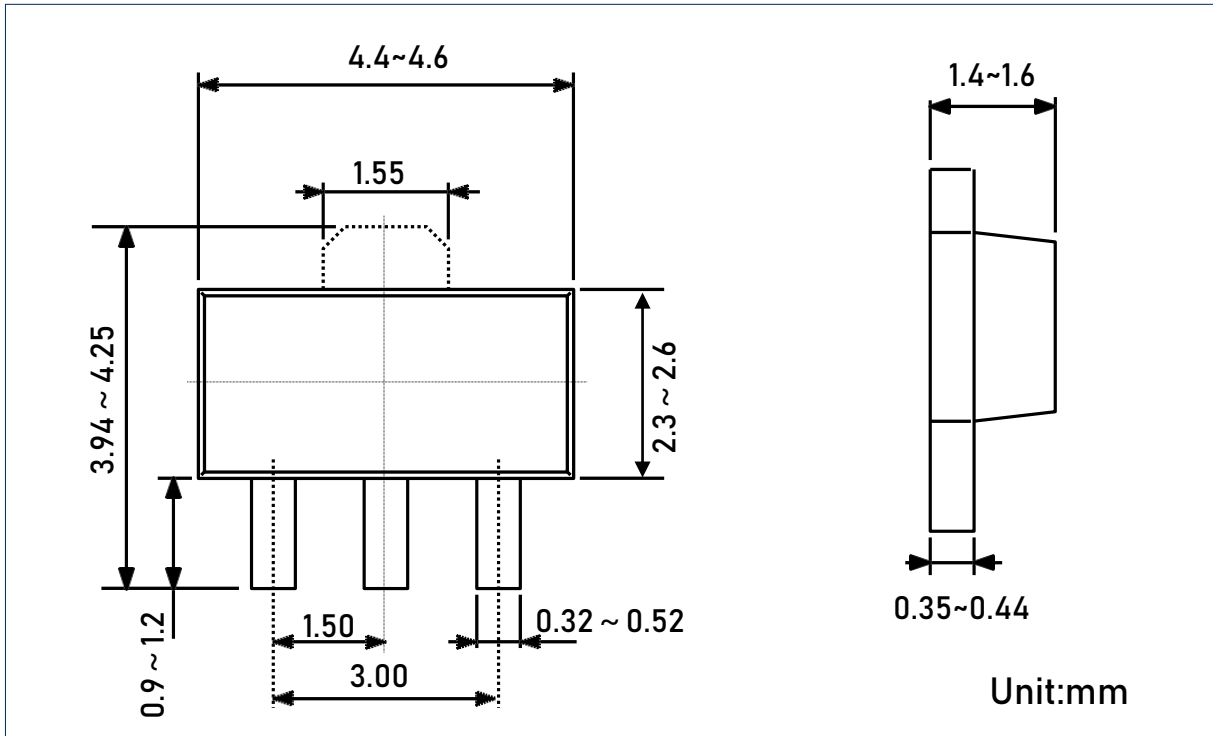

单击下面可查看定价，库存，交付和生命周期等信息

[>>Linearin\(先积\)](#)