

## General Description

The GP9301BM is an ADC with PWM output. The part can convert analog input signal ranging between 0V to 10V into a PWM signal with duty cycle going from 0% to 100%. The duty cycle has a linear error of less than +/- 0.5%. The input can also be connected directly to a 100K potentiometer or a PWM signal. The GP9301BM can also be used to provide a simple isolation interface using capacitor.

## Features

- GP9301B, analog voltage input from 0V to 10V is linearly converted into PWM signal output between 0%-100% duty cycle.
- GP9301BM, after converter to PWM signal, the signal is modulated into high frequency PWM to provide a simple isolation interface using capacitor.
- Analog Input signal between 0-10V. PWM, 100K $\Omega$  potentiometer
- Input PWM signal with logic high level: >2.7V
- Input signal VIN pin, built-in 100 $\mu$ A current source
- Output PWM signal frequency range: 1Hz to 1MHz
- Output PWM signal high level: 5V
- Maximum PWM duty cycle error (DNL): +/- 1%
- Maximum PWM duty linearity error (INL): +/- 0.5%
- Power supply voltage: 10V-40V
- Power consumption: 5mA@typ.
- Startup time: <2ms
- Operating temperature: -40  $^{\circ}$ C to 125  $^{\circ}$ C (H grade)

## Applications

- DC motor speed regulation
- LED Dimming
- Industrial analog signal isolation
- Inverter
- Power supply

## Pin Description

Pin. Name	Pin Description
VIN	Input analog voltage signal, compatible with PWM signal, 100K potentiometer
VCC	Power supply.
GND	Ground Pin.
V5V	Internal LDO, 5V output, a 4.7~22 $\mu$ F external capacitor is required, the performance of choosing 22 $\mu$ F is best
NC	No connect.
PWM	PWM Output
PWMB	complementary PWM Output

Table -A Pin. Name

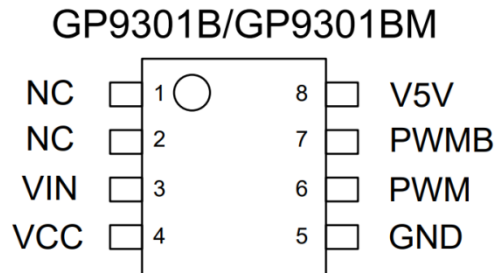

## Absolute Maximum Ratings

Operating Ambient Temperature Range	-40°C to 125°C
Storage Temperature Range	-50°C to 125°C
Input Voltage Range	-0.3 V to VCC + 0.3 V
Maximum voltage	40 V
ESD protection	> 2000 V

Note: Stresses exceeding those listed in the Maximum Rating stable may damage the device. Operation beyond the maximum Rating conditions or under harsh conditions may affect product reliability and function.

## Typical Application

### Typical Circuit

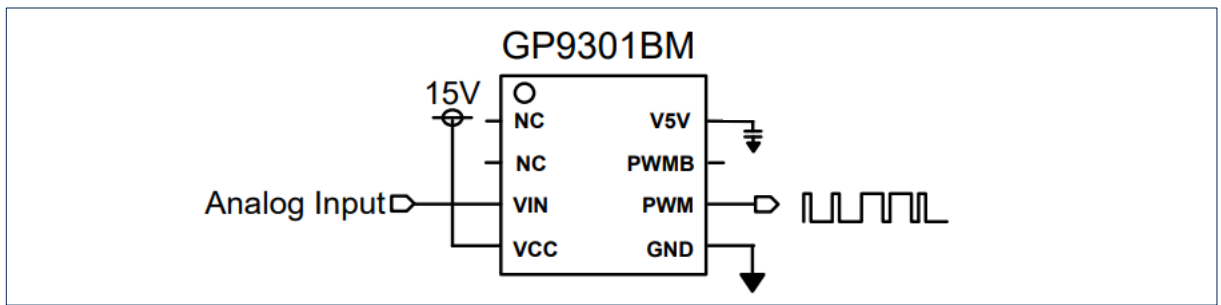
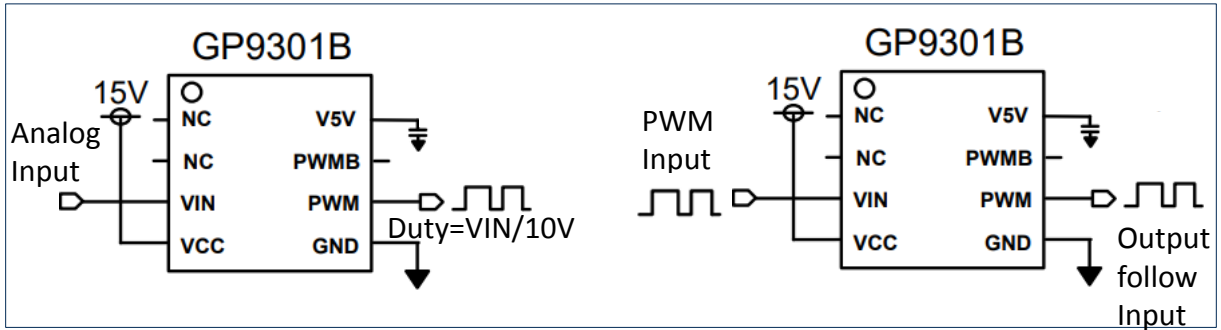

GP9301B analog voltage input and PWM output

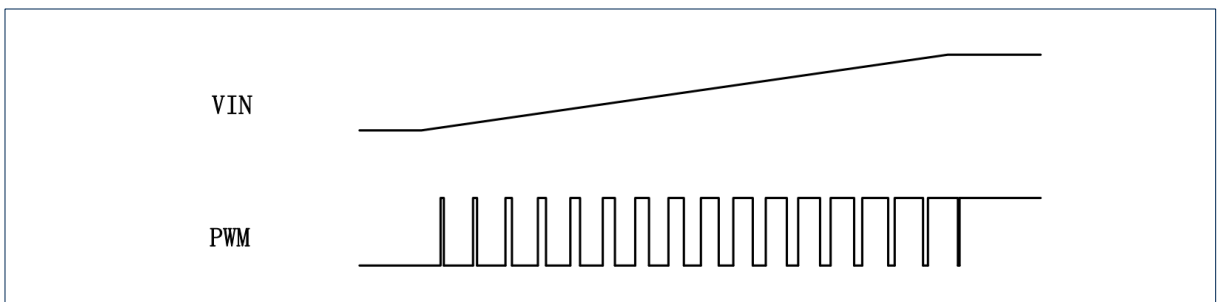

GP9301B and GP9301BM output signals difference

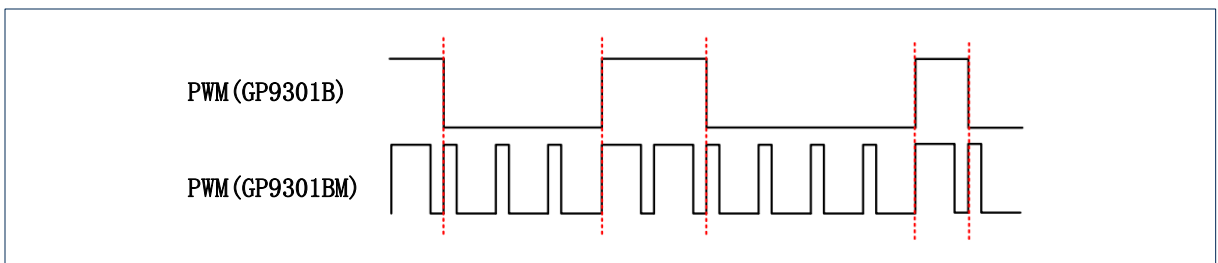

## Operating mode

### Typical function

The GP9301B is a high-performance APC (Analog to PWM Converter) which outputs PWM signals at frequencies ranging from 1Hz to 1MHz, 1kHz/4kHz/10kHz/20kHz are standard versions, other frequency output version can be special ordered. The input voltage range is 0V to 10V, and the duty cycles of the output PWM and PWMB signals are from 0% to 100%. The duty cycle of the PWM signal is related to the input voltage as the following conversation formula:

$$D_{PWM} = VIN/VCC \text{ (percentage)}$$

If an external potentiometer is used as input, there is a version of this part which has an optional internal 100uA current source. When connected to an external 100K potentiometer, the VIN pin can be pulled up internally to produce input voltage between 0V to 10V.

The GP9301BM modulates the GP9301B PWM output signal into higher frequency. The original ON time of the GP9301B PWM output is replaced with an output with 75% duty cycle at higher frequency. The OFF time is replaced with an output of 25% duty cycle at higher frequency. This modulation method can be used in capacitance isolation and transformer isolation application.

For the typical application circuits and application notes, please refer to Introduction of application and scheme.

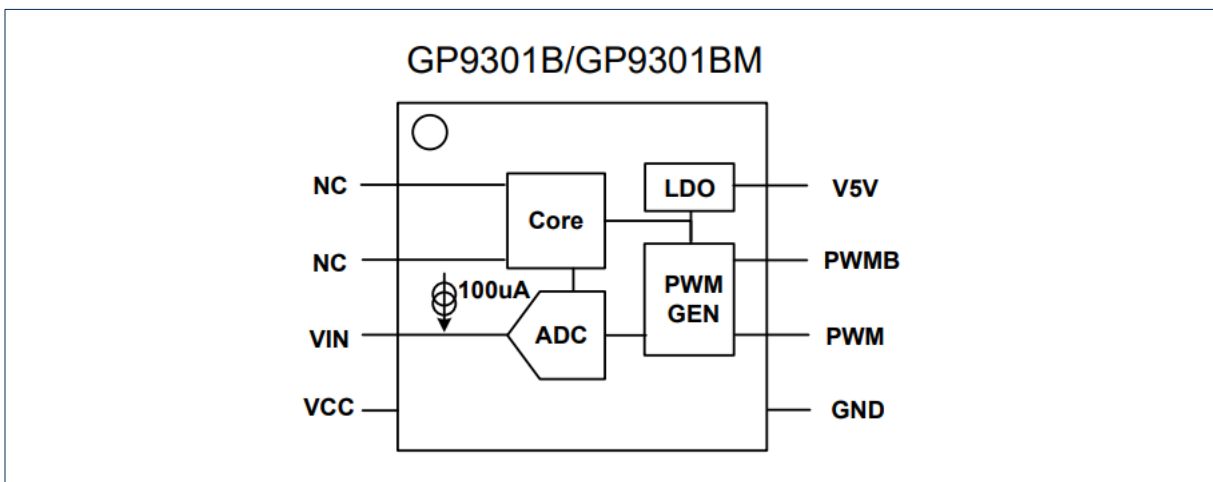

## AC Characteristics

Symbol	Parameter	Min.	Typ.	Max.	Unit.
$f_{pwm}$	PWM signal frequency <sup>(1)</sup>	1	1K	1M	Hz
$\Delta f_{pwm}$	Frequency error of PWM signal	-3	0	3	%
$\Delta D_{pwm}$	Duty cycle error of PWM signal		0.5	1	%
$D_{pwm}$	Duty cycle of PWM signal <sup>(2)</sup>	0		100	%
$J_{pwm}$	Jitter of PWM signal <sup>(3)</sup>		0.1	0.2	% <sub>p-p</sub>
$F_{BW}$	Bandwidth			1K	Hz

### Notes:

(1), The PWM signal frequency can be adjusted into the range from 1Hz to 1MHz. 1kHz/4kHz/10kHz/20kHz are standard versions, other frequency output versions can be special ordered. .

(2), The PWM duty ratio is defined as the average duty ratio, each cycle may not fully equal due to cycle jitter.

(3). Jitter is the ratio of the peak-to-peak deviation to the mean value in a period. The PWM jitter is measured at 1KHz frequency.

## DC Characteristics

Symbol	Parameter	Test Conditions	Min.	Typ.	Max.	Unit.
VCC	Power supply voltage		10	12	40	V
ICC	Power consumption	VCC @ 15.0V		5		mA
VIN	Input voltage	*	0		10	V
IIL	Input leakage current	VIN = VCC or VSS			3	μA
VOL	Voltage output Low	VCC @ 15.0V, IOL = 10 mA			0.8	V
VOH	Voltage output High	VCC @ 15.0V, IOL = 10 mA			4.2	V
Tr	Output rise time	VCC @ 15.0V, C <sub>LOAD</sub> =5pF		20	40	ns
Tf	Output fall time	VCC @ 15.0V, C <sub>LOAD</sub> =5pF		20	40	ns
IV5V*	V5V drive capability	VCC @ 15.0V		10		mA

\* the chip accuracy may be slightly affected by the load on V5V Pin.

## Introduction of application and scheme

### Typical GP9301B Circuits and points for attention

The 0-10V input of GP9301B is a dimming interface, which need to be protected when the operation condition is harsh.

In the following figure, the input has two levels of protection:

1. TVS protects against input ESD and surge.
2. RC filter can filter high frequency noise.

The resistance of the output is to prevent the reversed current from the load and provide anti-interference function.

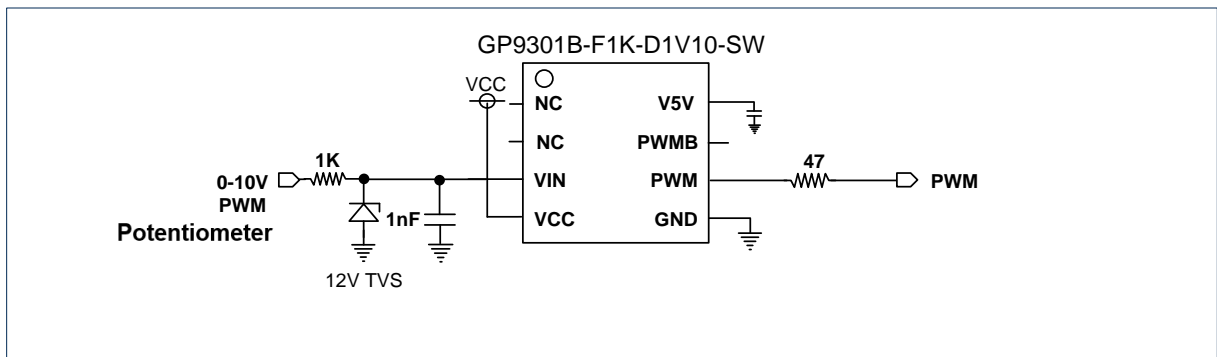

Typical application circuit 1: turn-off when input voltage lower than 0.6V . Compatible with 10V PWM signal.

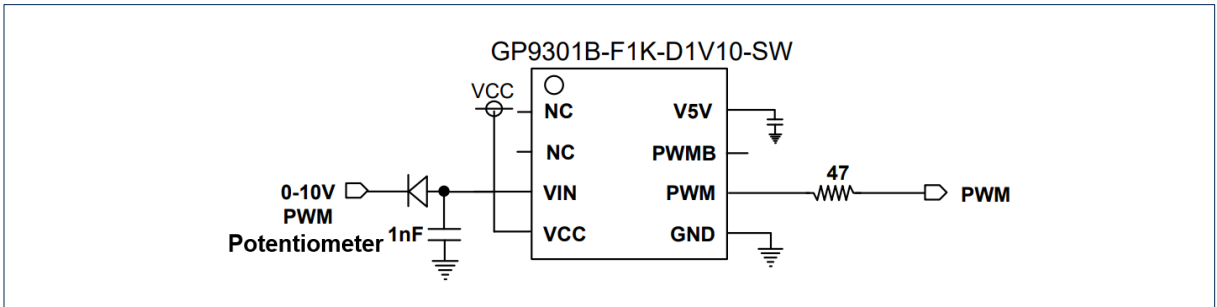

Typical application circuit 2: this circuit is compatible with the PWM signal of 2.7V-10V.

## Introduction of application and scheme

### 0-10V/PWM/ Potentiometer three-in-one Motor driver

The motor speed signal is regulated by analog voltage (0-10V/0-5V) or PWM signal, for the EC motor, the motor's power supply is connect to 220V/110V/380V power distribution network, and the speed signal connect to SELV, so the galvanic isolation is necessary. GP9301B converts the 0-10V analog voltage signal into PWM signal to drive isolation optocoupler for speed regulation.

The GP9301B not only supports 0-10V input, but also integrates the three-in-one input interface of PWM and 100K potentiometer, which optimizes the design of the interface circuit.

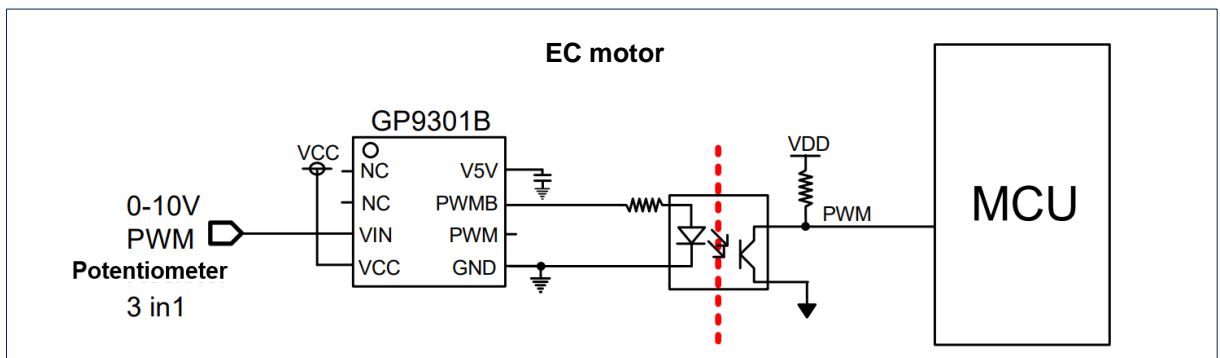

### Capacitance isolation scheme from 0 to 10V to PWM

Analog signal modulation chip GP9301BM+ isolation capacitor + signal demodulation chip GP6200. Electrical isolation is realized by capacitors, and the isolation strength depends on the spec of capacitor, so this scheme can set the isolation voltage strength.

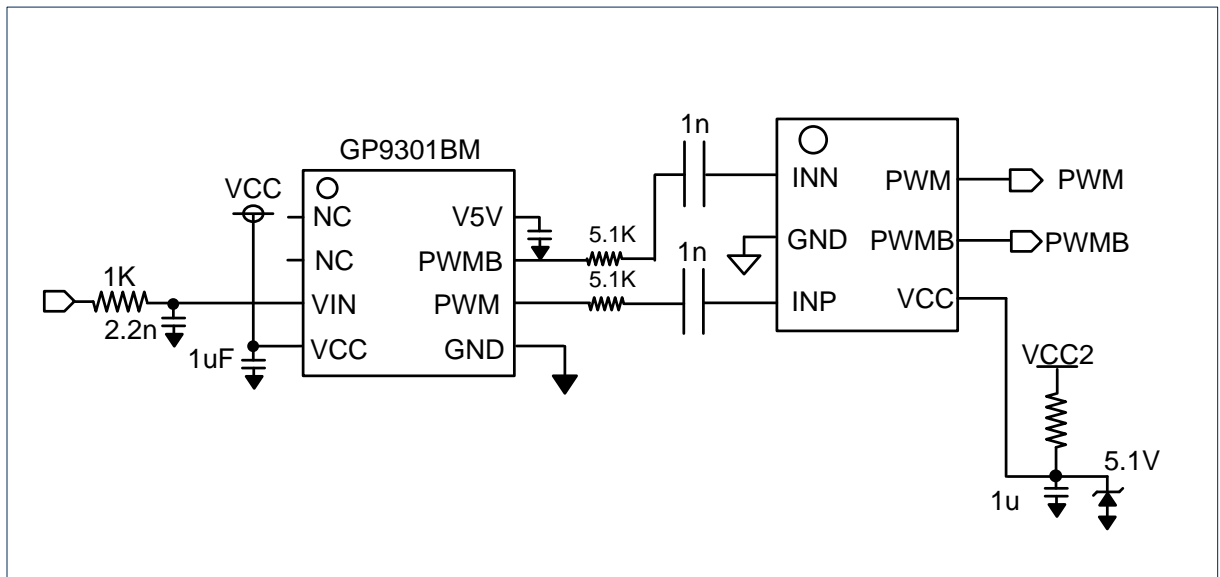

## Introduction of application and scheme

### 0-10V/PWM/ Potentiometer three-in-one color temperature dimming scheme

This is the circuit diagram of an LED color temperature control circuit with 0-10V/PWM/potentiometer input. The output voltage is fed into the GP9301B to produce a complementary pair of PWM signals (PWM and PWMB) that is proportional to the input's setting. The complementary pair is used to control the ON/OFF cycles of two strings of LED's by MOSFETs, realizing LED color temperature changes.

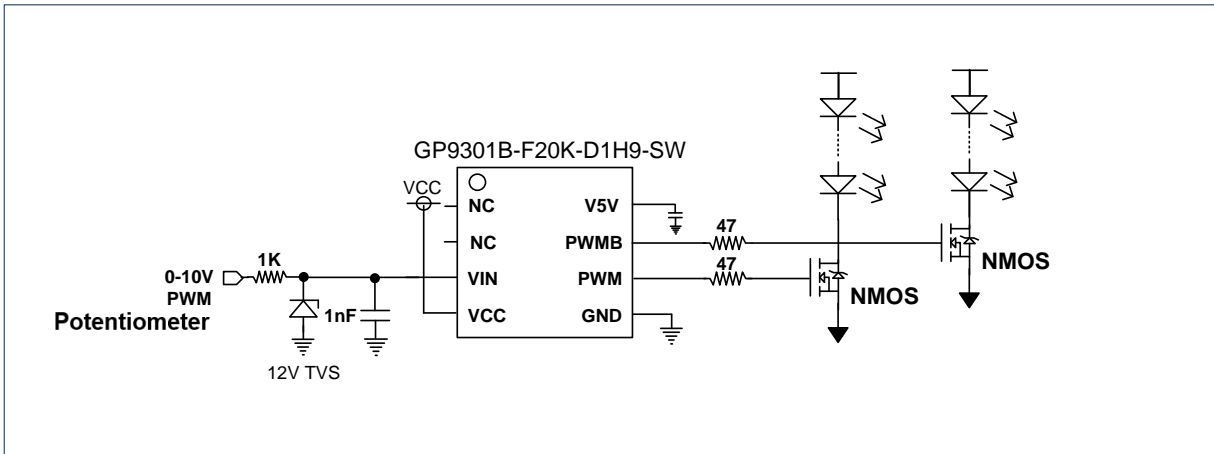

### 0-10V three-in-one dimming scheme

This circuit is a dimming interface converter whose input signal can be a 0/1~10V dimming signal, resistor, or PWM signal. It recognizes the signal automatically, a complementary pair of PWM signals (PWM and PWMB) generated by GP9301B, the duty cycle of the PWM signal is as the following :

$$D_{PWM} = VIN / 10V$$

The high level voltage of PWM and PWMB signals are 5V. The PWMB signal go through isolation optocoupler as the input signal of GP8012 for LED dimming.

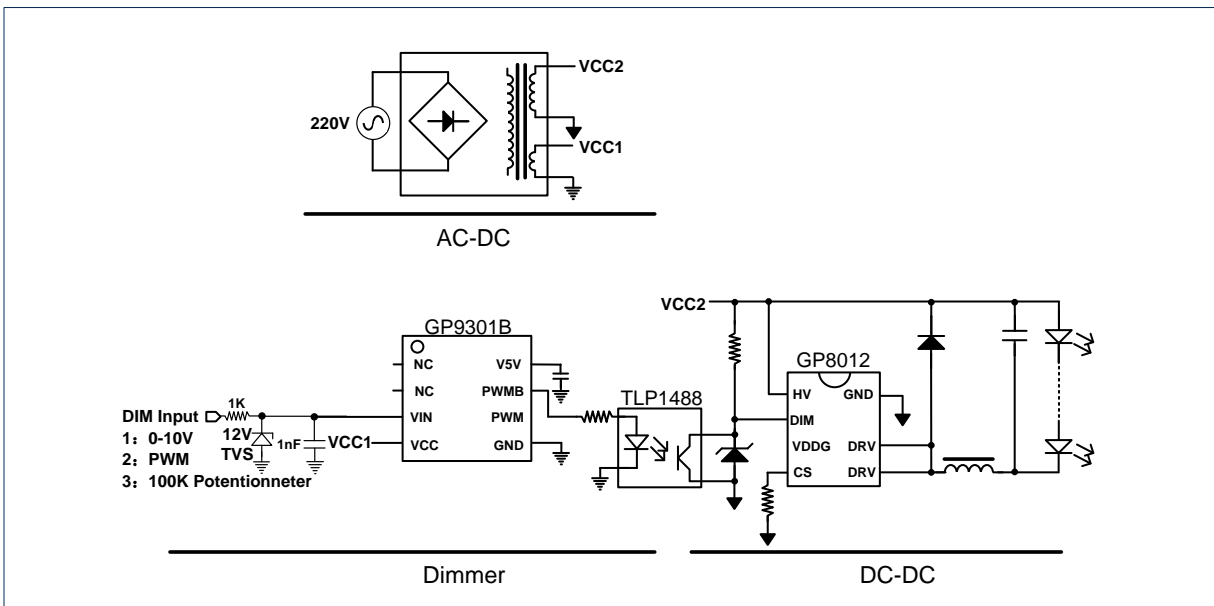



## Ordering Information

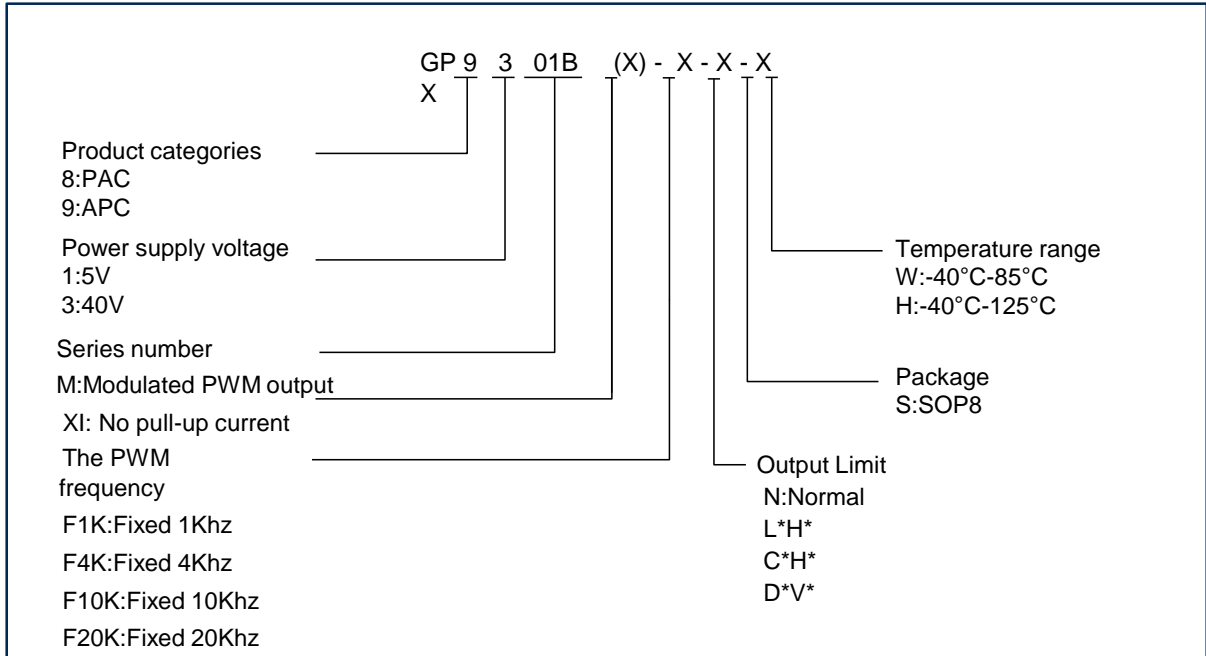

The GP9301B series products converter the analogy voltage to PWM signal(Output limit is D1V9), other output limit type can be selected as follows:

### Output Limit: N

No output limiter. 0V-10V corresponds to 0%-100% at PWM outputs. However, internal offset error can cause a small PWM output at 0V input or a 0% duty cycle PWN output when VIN has not yet reached 0V.

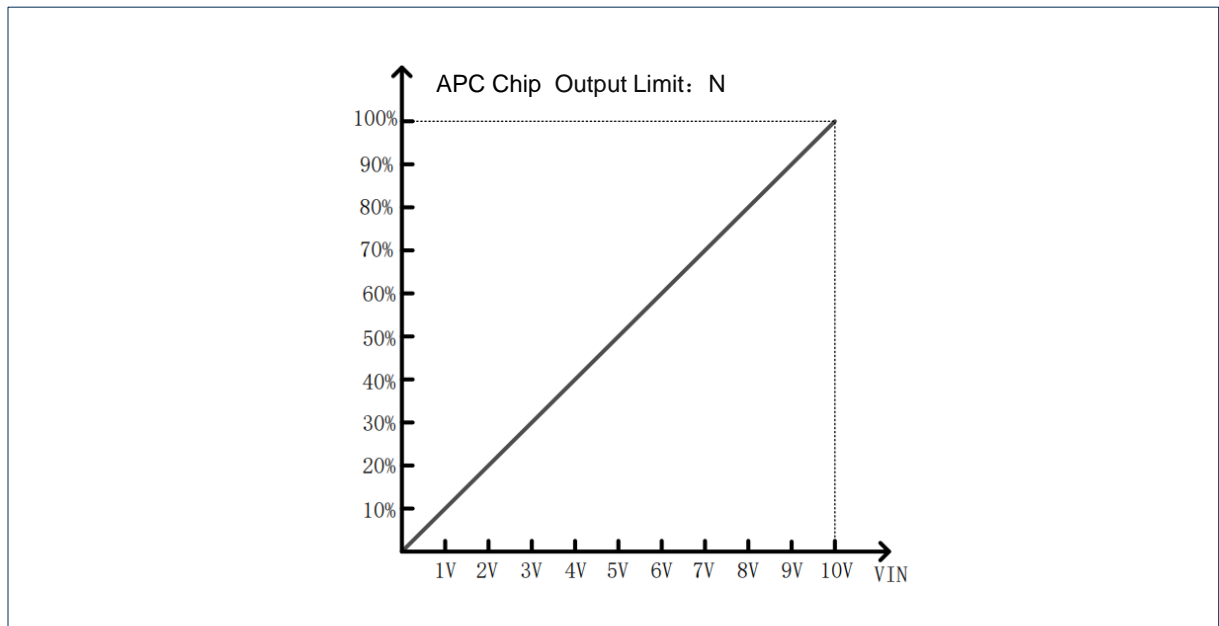

**Output limit: L \* H\***

The output (duty cycle) drops to 0% when VIN falls below a certain voltage. The output jumps to 100% when VIN exceeds a certain voltage. There are 4 options for the lower limit: 1%/2%/5%/10% and there are 4 upper limit options: 90%/95%/98%/99%. The part behaves the same way as the N grade part when VIN is in the normal operation range. See ordering information for details.

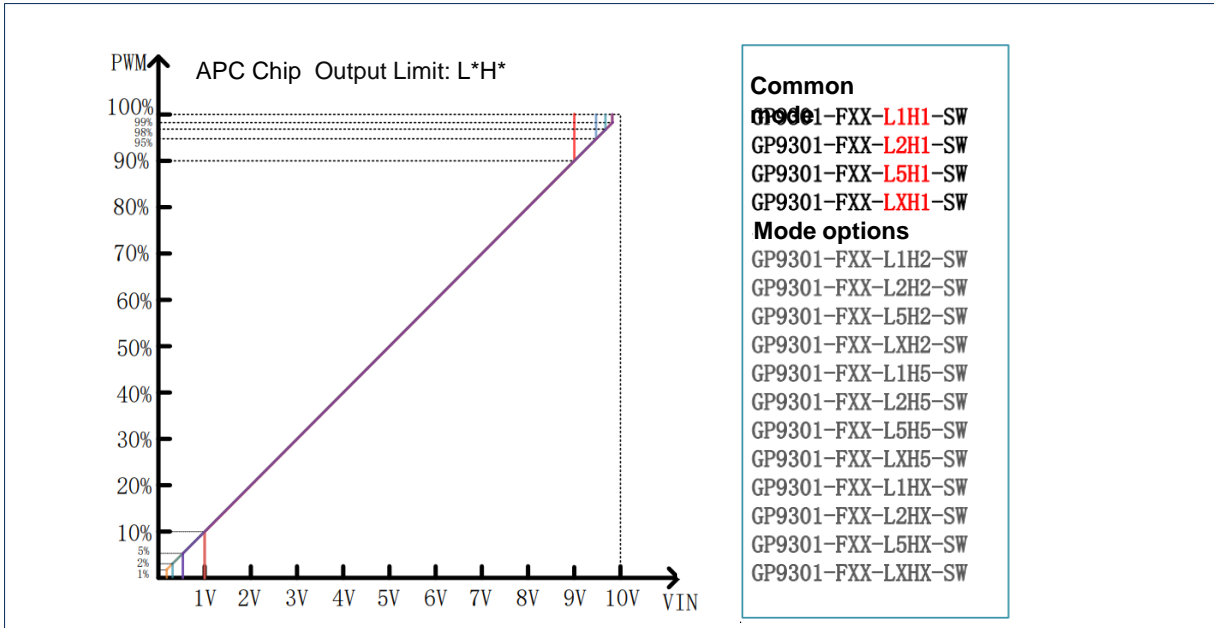

**Output Limit: C \* H\***

The output (duty cycle) will remain unchanged when VIN falls below a certain voltage. The output jumps to 100% when VIN exceeds a certain voltage, There are 4 options for the lower limit: 1%/2%/5%/10% and there are 4 upper limit options: 90%/95%/98%/99%. The part behaves the same way as the N grade part when VIN is in the normal operation range. See ordering information for details.

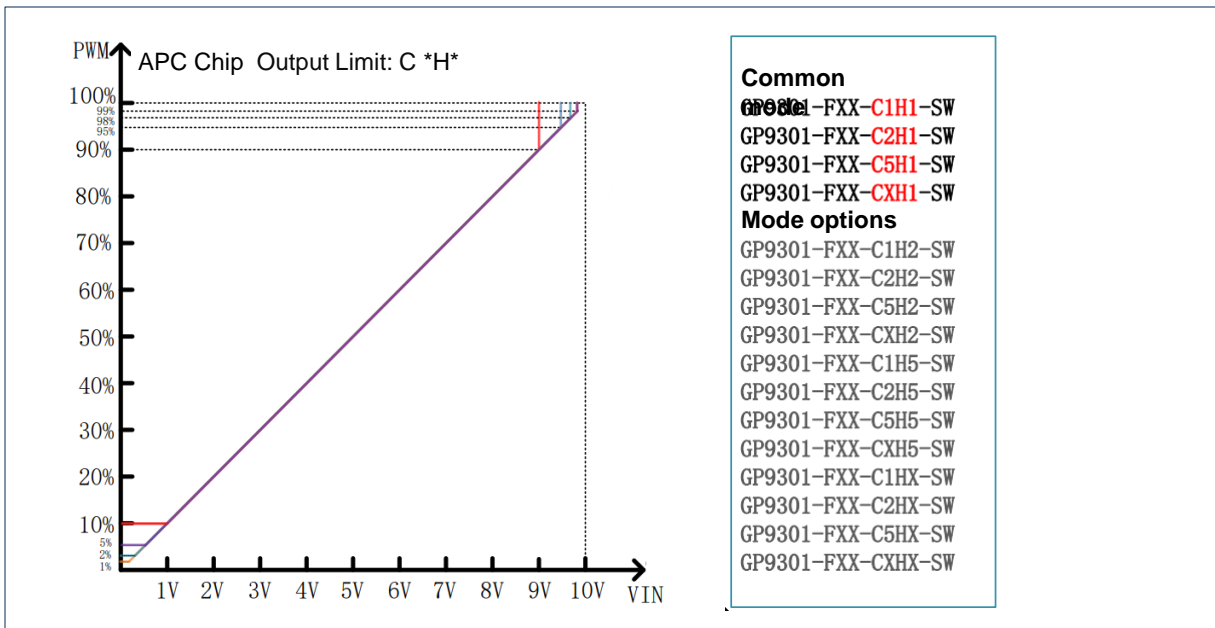

\* Different PWM frequencies and output limit types of 9301B can be ordered.

P-  
11

## GP9301B/GP9301BM

### Analog to PWM Converter (APC)

#### 0-10V/PWM/Potentiometer Input with PWM Output

#### Output Limit: $D \cdot V^*$

The typical dimming curve description: (the voltage error range is less than +/- 1%).

1. The start-up voltage of VIN is Va (rising from 0V) and the turn-off voltage is Vb (falling from high voltage).
2. The output PWM duty cycle is constant 0% corresponds to input from Va to Vc.
3. The output PWM duty cycle is 0 ~ 99% corresponds to input from Vc to 9V.
4. When VIN exceeds 9V, the output PWM duty cycle jump to 100%.

\* the measured data of voltage of Va, Vb and Vc are as follows:

Sample	Va	Vb	Vc	Duty0
#1	0.63V	0.78V	0.94V	0.9%
#2	0.61V	0.76V	0.95V	0.9%
#3	0.62V	0.77V	0.95V	1.0%
#4	0.67V	0.81V	1.00V	1.0%
#5	0.64V	0.78V	0.96V	1.0%

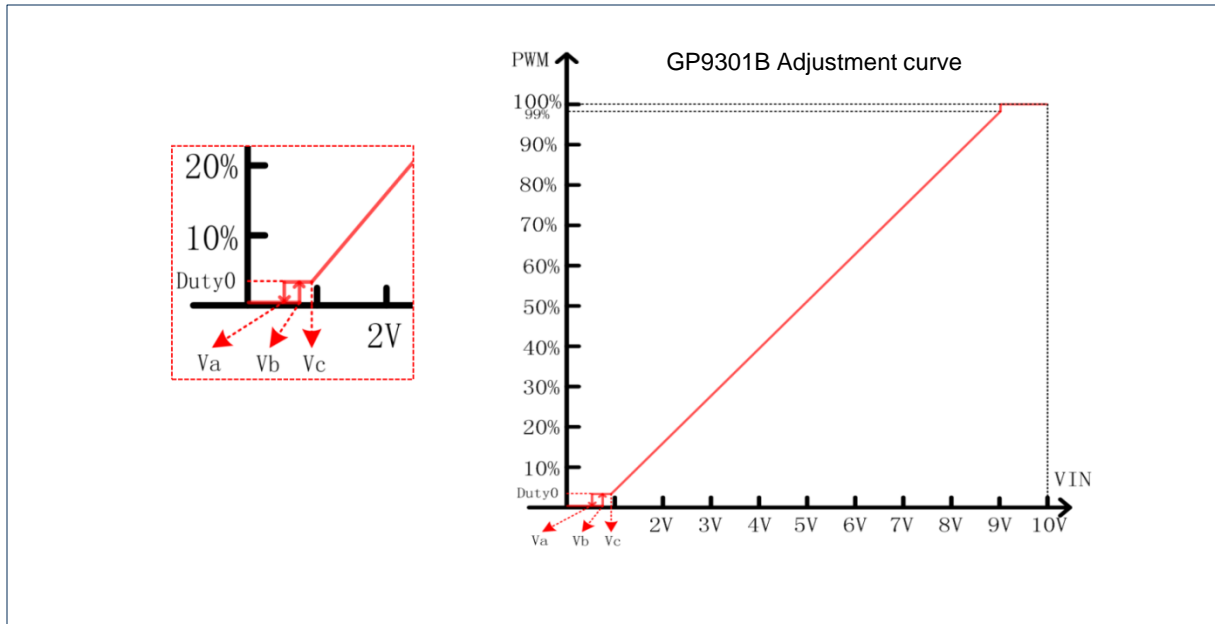

Take GP9301B-F1K-D1V9-SW as an example, F1K means the frequency is 1kHz, D1V9 means that when the input voltage drops to 1V, the output PWM duty cycle is 1%, when the input voltage rises to 9V, the output PWM duty cycle is 100%. The turn-off voltage is fixed at 0.6V. SW means SOP8 package and operating temperature of -40 °C to 85 °C.

Likewise:

GP9301B-F4K-D5V9-SW means frequency 4KHz, dimming depth is 5%, input voltage rise to 9V then the output PWM duty cycle up to 100%.

GP9301B-F4K-D1V10-SW means frequency 4KHz, dimming depth is 1%, input voltage rise to 9V then the output PWM duty cycle up to 100%.

GP9301B-F1K-D5V10-SW means frequency 1KHz, dimming depth is 5%, input voltage rise to 10V then the output PWM duty cycle up to 100%.

GP9301B series selection

Operating temperature	PWM frequency *1	Output Limit*2	Ordering Number
-40°C-85°C	1KHz	D*V*	GP9301B-F1K-D*V*-SH
-40°C-85°C	1KHz	C*H*	GP9301B-F1K-C*H*-SH
-40°C-85°C	1KHz	L*H*	GP9301B-F1K-L*H*-SH
-40°C-85°C	1KHz	N	GP9301B-F1K-N-SH

\* You can choose different frequencies and output limit types as required

### Package Dimension

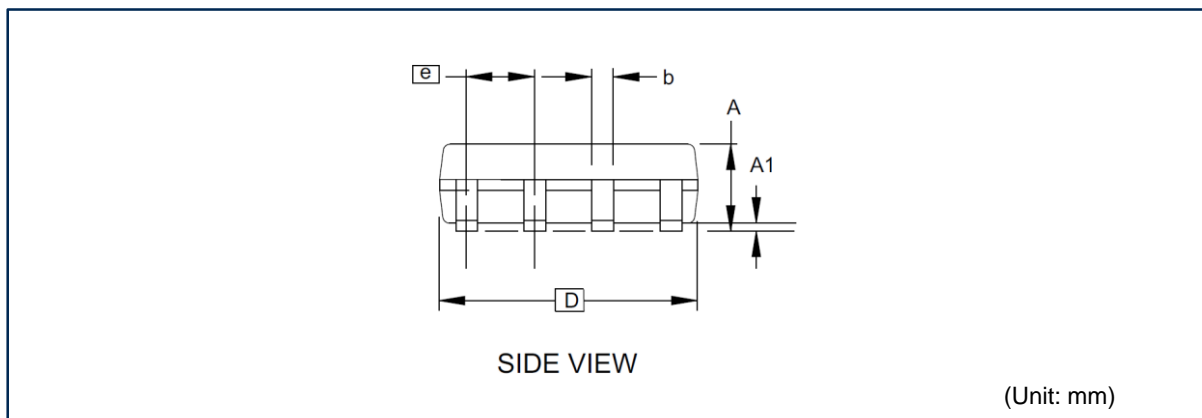
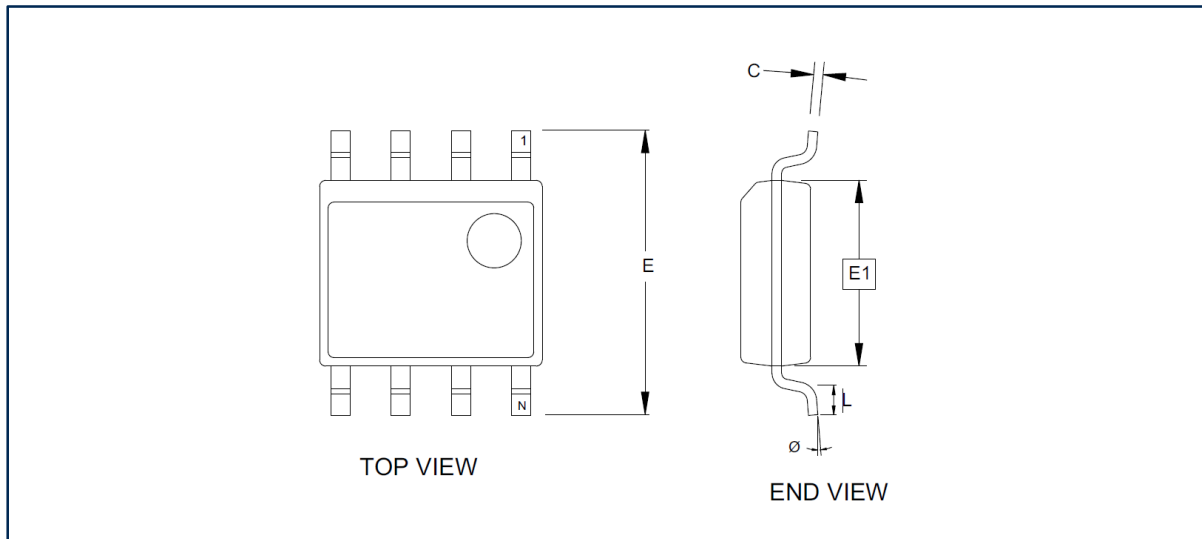

Symbol	Min.	Typ.	Max.
A1	0.10	–	0.25
A	1.35	–	1.75
b	0.31	–	0.51
C	0.17	–	0.25
D	4.80	–	5.05
E1	3.81	–	3.99
E	5.79	–	6.20
e	1.27 BSC		
L	0.40	–	1.27
Ø	0°	–	8°

Note:

- This figure is for general reference only. Refer to JEDEC drawing MS-012 for proper dimensions, tolerances, datum, etc.

单击下面可查看定价，库存，交付和生命周期等信息

[>>Linearin\(先积\)](#)