

## General Description

The LTC8541 (single), LTC8542 (dual) and LTC8544 (quad) are low voltage micro power CMOS voltage feedback operational amplifiers. With an excellent bandwidth of 1.1MHz, a slew rate of 0.9V/µs, and a quiescent current of 70µA per amplifier at 5V, the LTC854x family can be designed into a wide range of applications.

The LTC854x op-amps are specifically designed for general-purpose applications with optimal performance. They have a wide input common-mode voltage range and output voltage swing, and the maximum input offset voltage are 3.5mV. These parts provide rail-to-rail output swing into heavy loads. The LTC854x family is specified for single or dual power supplies of +2.3V to +6.0V. All models are specified over the extended industrial temperature range of -40°C to +125°C.

The LTC8541 is available in 5-lead SC70 and SOT-23, and 8-lead SOIC packages. The LTC8542 is available in 8-lead DFN2x2, MSOP and SOIC packages. The LTC8544 is available in 14-lead TSSOP and SOIC packages.

## Features and Benefits

- High Gains of >102 dB for Active Filters and Gain Stages
- Low Offset Voltage: 3.5 mV Maximum with 2 µV/°C Low Drift
- Gain-Bandwidth Product: 1.1MHz
- High Slew Rate: 0.9 V/µs
- Low Power: 70 µA per Amplifier Supply Current
- Settling Time to 0.1% with 2V Step: 4.1 µs
- Unity Gain Stable
- Very Low Input Bias Current: 1pA
- Rail-to-Rail Input and Output
  - Input Voltage Range: -0.2 to +5.2 V at 5V Supply
- Operating Power Supply: +2.3 to +6.0 V
- Operating Temperature Range: -40°C to +125°C
- ESD Rating: HBM – 4kV, CDM – 2kV

## Applications

- Smoke/Gas/Environment Sensors
- Audio Outputs
- Active Filters
- ASIC Input or Output Amplifier
- Sensor Interfaces
- Portable Equipment
- Battery-Powered Instrumentation

## Pin Configurations (Top View)

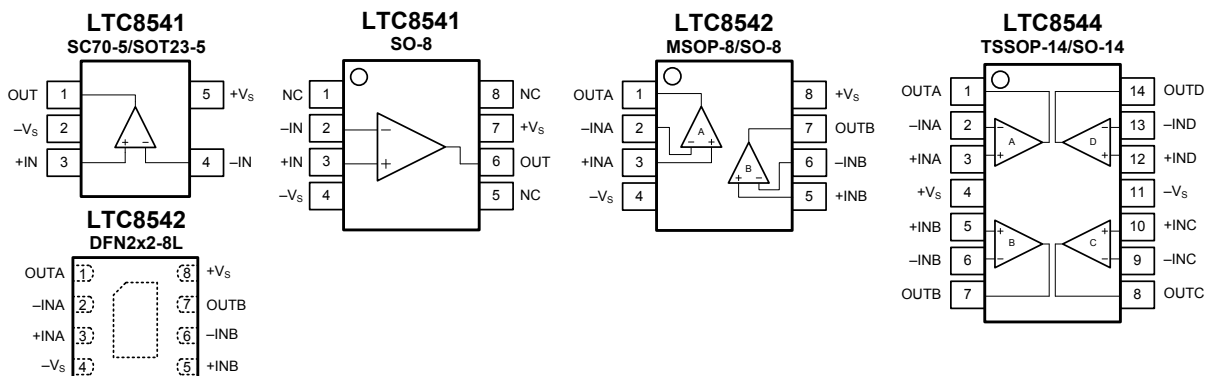

# LTC8541, LTC8542, LTC8544

1.1MHz, 70µA, CMOS RRIO Operational Amplifiers

## Pin Description

Symbol	Description
–IN	Inverting input of the amplifier. The voltage range can go from ( $V_{S-} - 0.2V$ ) to ( $V_{S+} + 0.2V$ ).
+IN	Non-inverting input of the amplifier. This pin has the same voltage range as –IN.
+V <sub>S</sub>	Positive power supply. The voltage is from 2.3V to 6.0V. Split supplies are possible as long as the voltage between V <sub>S+</sub> and V <sub>S-</sub> is between 2.3V and 6.0V. A bypass capacitor of 0.1µF as close to the part as possible should be used between power supply pins or between supply pins and ground.
–V <sub>S</sub>	Negative power supply. It is normally tied to ground. It can also be tied to a voltage other than ground as long as the voltage between V <sub>S+</sub> and V <sub>S-</sub> is from 2.3V to 6.0V. If it is not connected to ground, bypass it with a capacitor of 0.1µF as close to the part as possible.
OUT	Amplifier output.
N/C	No internal connection.

## Ordering Information

Type Number	Package Name	Package Quantity	Marking Code
LTC8541XC5/R6	SC70-5	Tape and Reel, 3 000	C41
LTC8541XT5/R6	SOT23-5	Tape and Reel, 3 000	C41
LTC8541XS8/R8	SO-8	Tape and Reel, 4 000	C41X
LTC8542XF8/R6	DFN2x2-8L	Tape and Reel, 3 000	C42
LTC8542XV8/R6	MSOP-8	Tape and Reel, 3 000	C42X
LTC8542XS8/R8	SO-8	Tape and Reel, 4 000	C42X
LTC8544XT14/R6	TSSOP-14	Tape and Reel, 3 000	C44X
LTC8544XS14/R5	SO-14	Tape and Reel, 2 500	C44X

## Limiting Value

*In accordance with the Absolute Maximum Rating System (IEC 60134).*

Parameter	Absolute Maximum Rating
Supply Voltage, V <sub>S+</sub> to V <sub>S-</sub>	10.0V
Common-Mode Input Voltage	V <sub>S-</sub> – 0.5V to V <sub>S+</sub> + 0.5V
Storage Temperature Range	–65°C to +150°C
Junction Temperature	160°C
Lead Temperature Range (Soldering 10 sec)	260°C
Electrostatic Discharge Voltage	HBM ±4 000V
	CDM ±2 000V
	MM ±400V

## Electrical Characteristics

$V_S = 5.0V$ ,  $T_A = +25^\circ C$ ,  $V_{CM} = V_S/2$ ,  $V_O = V_S/2$ , and  $R_L = 10k\Omega$  connected to  $V_S/2$ , unless otherwise noted. **Boldface limits apply over the specified temperature range,  $T_A = -40$  to  $+125^\circ C$ .**

Symbol	Parameter	Conditions	Min.	Typ.	Max.	Unit
<b>INPUT CHARACTERISTICS</b>						
$V_{OS}$	Input offset voltage		-3.5	±0.5	+3.5	mV
	<b>over Temperature</b>		<b>-3.8</b>		<b>+3.8</b>	
$V_{OS\ TC}$	Offset voltage drift	<b>over Temperature</b>		<b>2</b>		µV/°C
$I_B$	Input bias current			1		pA
	<b>over Temperature</b>				<b>800</b>	
$I_{OS}$	Input offset current			1		pA
$V_{CM}$	Common-mode voltage range		$V_{S-}-0.2$		$V_{S+}+0.2$	V
CMRR	Common-mode rejection ratio	$V_{CM} = 0.05V$ to $3.5V$	80	97		dB
	<b>over Temperature</b>		<b>70</b>			
	<b>over Temperature</b>	$V_{CM} = V_{S-}-0.1$ to $V_{S+}+0.1V$	70	82		
$A_{VOL}$	Open-loop voltage gain	$R_L = 10k\Omega$ , $V_O = 0.05$ to $3.5V$	102	116		dB
	<b>over Temperature</b>		<b>90</b>			
	<b>over Temperature</b>	$R_L = 2k\Omega$ , $V_O = 0.15$ to $3.5V$	93	108		
	<b>over Temperature</b>		<b>82</b>			
$R_{IN}$	Input resistance		100			GΩ
$C_{IN}$	Input capacitance	Differential		2.0		pF
		Common mode		3.5		
<b>OUTPUT CHARACTERISTICS</b>						
$V_{OH}$	High output voltage swing	$R_L = 10k\Omega$		$V_{S+}-5$		mV
		$R_L = 600\Omega$		$V_{S+}-75$		
$V_{OL}$	Low output voltage swing	$R_L = 10k\Omega$		5		mV
		$R_L = 600\Omega$		75		
$Z_{OUT}$	Closed-loop output impedance	$f = 200kHz$ , $G = +1$		0.4		Ω
	Open-loop output impedance	$f = 1MHz$ , $I_O = 0$		2.6		
$I_{SC}$	Short-circuit current	Source current through $10\Omega$		60		mA
		Sink current through $10\Omega$		45		
<b>DYNAMIC PERFORMANCE</b>						
GBW	Gain bandwidth product	$f = 1kHz$		1.1		MHz
$\Phi_M$	Phase margin	$C_L = 100pF$		66		°
SR	Slew rate	$G = +1$ , $C_L = 100pF$ , $V_O = 1.5V$ to $3.5V$		0.9		V/µs
$t_s$	Settling time	To 0.1%, $G = +1$ , 2V step		4.1		µs
		To 0.01%, $G = +1$ , 2V step		5.1		
THD+N	Total harmonic distortion + noise	$f = 1kHz$ , $G = +1$ , $V_O = 3V_{PP}$		0.0018		%



Typical Performance Characteristics

At  $T_A = +25^\circ\text{C}$ ,  $V_{CM} = V_S/2$ , and  $R_L = 10\text{k}\Omega$  connected to  $V_S/2$ , unless otherwise noted.

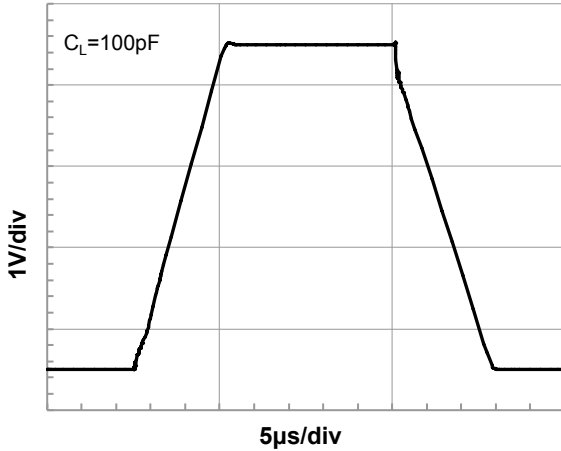

Large Signal Step Response.

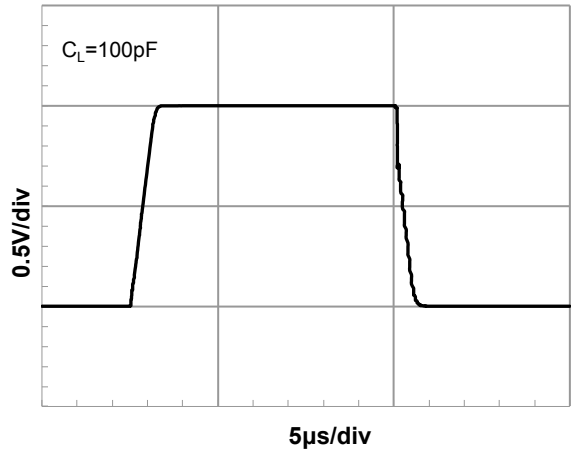

Small Signal Step Response.

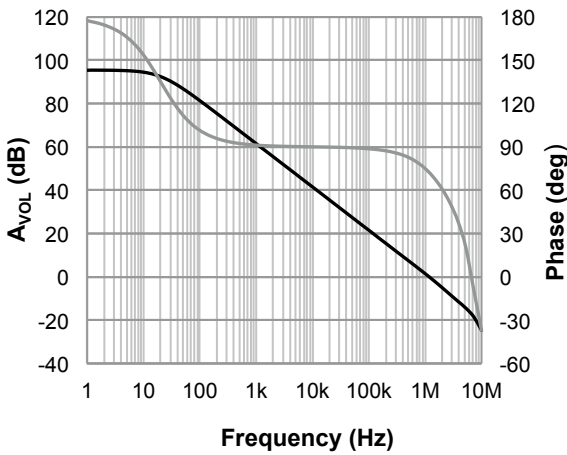

Open-loop Gain and Phase as a function of Frequency.

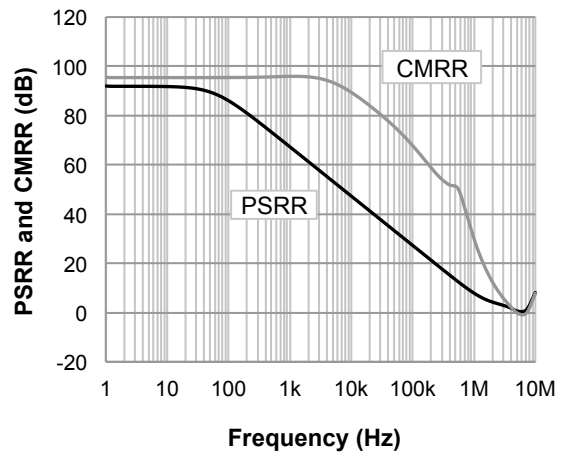

Power Supply and Common-mode Rejection Ratio as a function of Frequency.

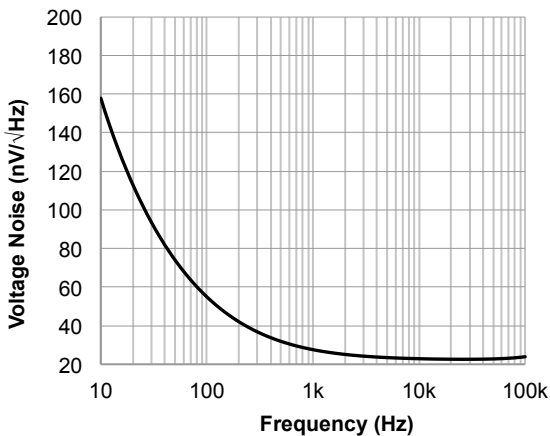

Input Voltage Noise Spectral Density as a function of Frequency.

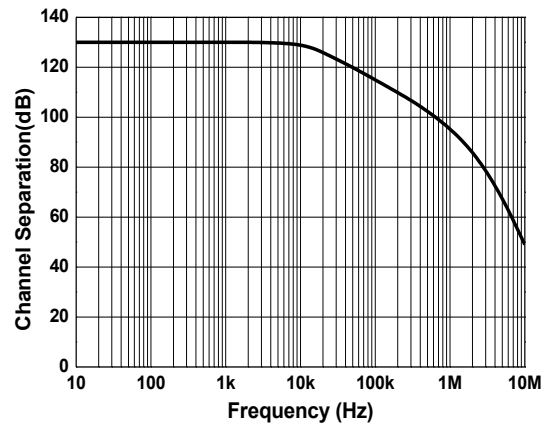

Channel Separation as a function of Frequency.

# LTC8541, LTC8542, LTC8544

1.1MHz, 70µA, CMOS RRIO Operational Amplifiers

## Typical Performance Characteristics (continued)

At  $T_A = +25^\circ\text{C}$ ,  $V_{CM} = V_S/2$ , and  $R_L = 10\text{k}\Omega$  connected to  $V_S/2$ , unless otherwise noted.

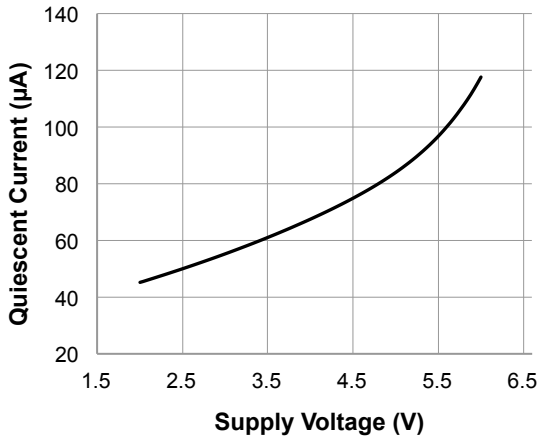

Quiescent Current as a function of Supply Voltage.

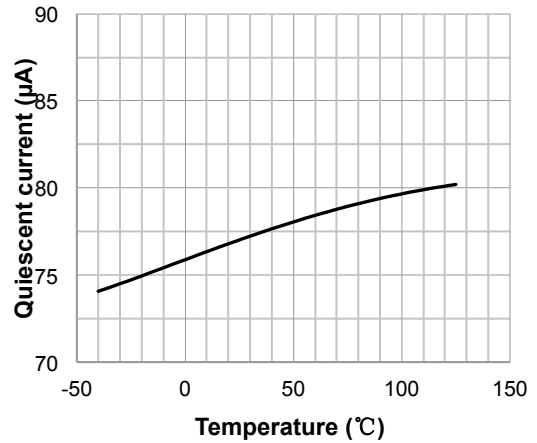

Quiescent Current as a function of Temperature.

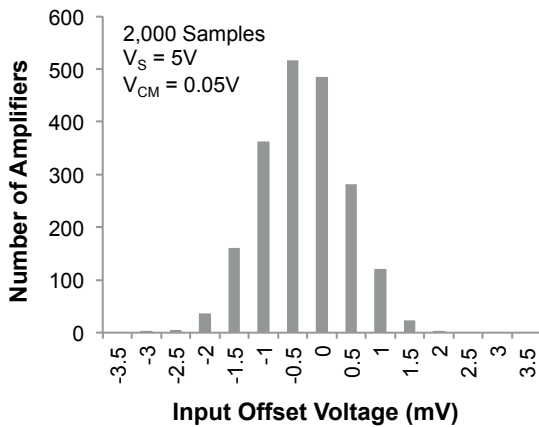

Input Offset Voltage Production Distribution.

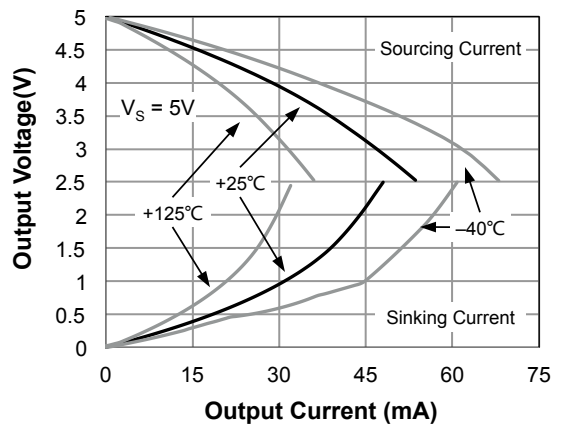

Output Voltage Swing as a function of Output Current.

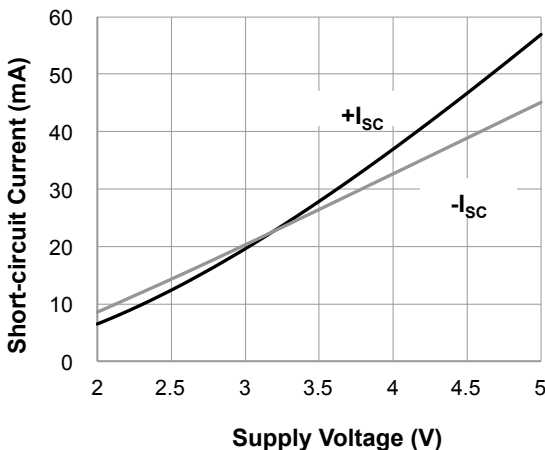

Short-circuit Current as a function of Supply Voltage.

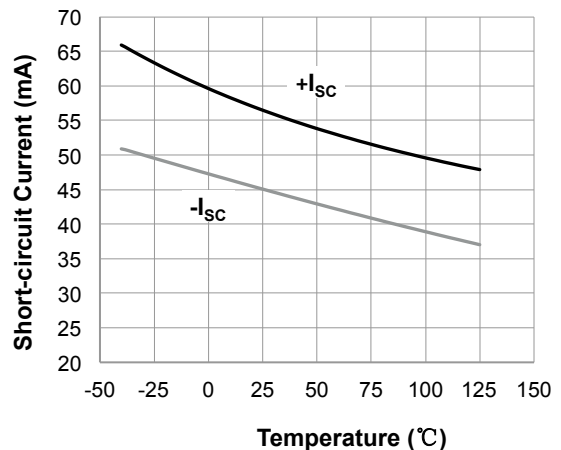

Short-circuit Current as a function of Temperature.

## Application Notes

### LOW INPUT BIAS CURRENT

The LTC854x family is a CMOS op-amp family and features very low input bias current in pA range. The low input bias current allows the amplifiers to be used in applications with high resistance sources. Care must be taken to minimize PCB Surface Leakage. See below section on “PCB Surface Leakage” for more details.

### PCB SURFACE LEAKAGE

In applications where low input bias current is critical, Printed Circuit Board (PCB) surface leakage effects need to be considered. Surface leakage is caused by humidity, dust or other contamination on the board. Under low humidity conditions, a typical resistance between nearby traces is  $10^{12}\Omega$ . A 5V difference would cause 5pA of current to flow, which is greater than the LTC854x's input bias current at +25°C ( $\pm 1\text{fA}$ , typical). It is recommended to use multi-layer PCB layout and route the op-amp's -IN and +IN signal under the PCB surface.

The effective way to reduce surface leakage is to use a guard ring around sensitive pins (or traces). The guard ring is biased at the same voltage as the sensitive pin. An example of this type of layout is shown in Figure 1 for Inverting Gain application.

- For Non-Inverting Gain and Unity-Gain Buffer:
  - Connect the non-inverting pin (+IN) to the input with a wire that does not touch the PCB surface.
  - Connect the guard ring to the inverting input pin (-IN). This biases the guard ring to the Common Mode input voltage.
- For Inverting Gain and Trans-impedance Gain Amplifiers (convert current to voltage, such as photo detectors):
  - Connect the guard ring to the non-inverting input pin (+IN). This biases the guard ring to the same reference voltage as the op-amp (e.g.,  $V_S/2$  or ground).
  - Connect the inverting pin (-IN) to the input with a wire that does not touch the PCB surface.

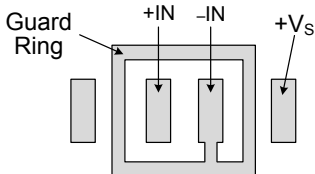

Figure 1. Use a guard ring around sensitive pins

### GROUND SENSING AND RAIL TO RAIL

The input common-mode voltage range of the LTC854x series extends 200mV beyond the supply rails. This is achieved with a complementary input stage—an N-channel input differential pair in parallel with a P-channel differential pair. For normal operation, inputs should be limited to this range. The absolute maximum input voltage is 500mV beyond the supplies. Inputs greater than the input common-mode range but less than the maximum input voltage, while not valid, will not cause any damage to the op-amp. Unlike some other op-amps, if input current is limited, the inputs may go beyond the supplies without phase inversion, as shown in Figure 2. Since the input common-mode range extends from  $(V_{S-} - 0.2\text{V})$  to  $(V_{S+} + 0.2\text{V})$ , the LTC854x op-amps can easily perform 'true ground' sensing. A topology of class AB output stage with common-source transistors is used to achieve rail-to-rail output. For light

resistive loads (e.g. 100kΩ), the output voltage can typically swing to within 5mV from the supply rails. With moderate resistive loads (e.g. 10kΩ), the output can typically swing to within 10mV from the supply rails and maintain high open-loop gain. See the Typical Characteristic curve, Output Voltage Swing as a function of Output Current, for more information.

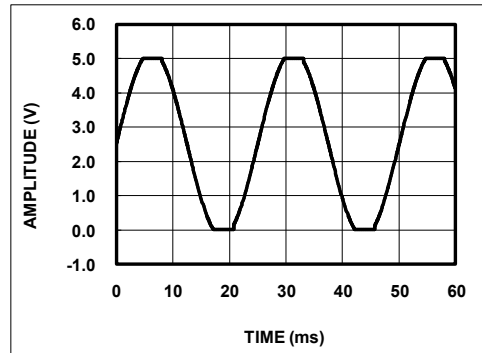

Figure 2. No Phase Inversion with Inputs Greater Than the Power-Supply Voltage

The maximum output current is a function of total supply voltage. As the supply voltage to the amplifier increases, the output current capability also increases. Attention must be paid to keep the junction temperature of the IC below 150°C when the output is in continuous short-circuit. The output of the amplifier has reverse-biased ESD diodes connected to each supply. The output should not be forced more than 0.5V beyond either supply, otherwise current will flow through these diodes.

### CAPACITIVE LOAD AND STABILITY

The LTC854x can directly drive 1nF in unity-gain without oscillation. The unity-gain follower (buffer) is the most sensitive configuration to capacitive loading. Direct capacitive loading reduces the phase margin of amplifiers and this results in ringing or even oscillation. Applications that require greater capacitive drive capability should use an isolation resistor between the output and the capacitive load like the circuit in Figure 3. The isolation resistor  $R_{ISO}$  and the load capacitor  $C_L$  form a zero to increase stability. The bigger the  $R_{ISO}$  resistor value, the more stable  $V_{OUT}$  will be. Note that this method results in a loss of gain accuracy because  $R_{ISO}$  forms a voltage divider with the  $R_L$ .

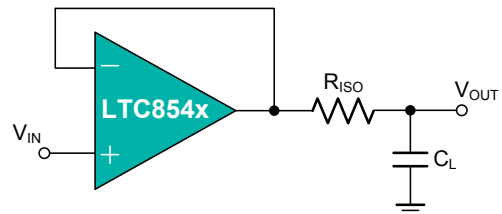

Figure 3. Indirectly Driving Heavy Capacitive Load

An improvement circuit is shown in Figure 4. It provides DC accuracy as well as AC stability. The  $R_F$  provides the DC accuracy by connecting the inverting signal with the output. The  $C_F$  and  $R_{ISO}$  serve to counteract the loss of phase margin by feeding the high frequency component of the output signal back to the amplifier's inverting input, thereby preserving phase margin in the overall feedback loop.

## Application Notes (continued)

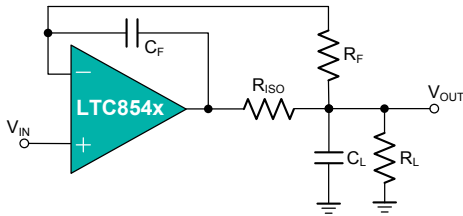

Figure 4. Indirectly Driving Heavy Capacitive Load with DC Accuracy

For no-buffer configuration, there are two other ways to increase the phase margin: (a) by increasing the amplifier's gain, or (b) by placing a capacitor in parallel with the feedback resistor to counteract the parasitic capacitance associated with inverting node.

### POWER SUPPLY LAYOUT AND BYPASS

The LTC854x family operates from either a single +2.3V to +6.0V supply or dual  $\pm 1.15V$  to  $\pm 3.00V$  supplies. For single-supply operation, bypass the power supply  $V_S$  with a ceramic capacitor (i.e. 0.01µF to 0.1µF) which should be placed close (within 2mm for good high frequency performance) to the  $V_S$  pin. For dual-supply operation, both the  $V_{S+}$  and the  $V_{S-}$  supplies should be bypassed to ground

with separate 0.1µF ceramic capacitors. A bulk capacitor (i.e. 2.2µF or larger tantalum capacitor) within 100mm to provide large, slow currents and better performance. This bulk capacitor can be shared with other analog parts.

Good PC board layout techniques optimize performance by decreasing the amount of stray capacitance at the op-amp's inputs and output. To decrease stray capacitance, minimize trace lengths and widths by placing external components as close to the device as possible. Use surface-mount components whenever possible. For the op-amp, soldering the part to the board directly is strongly recommended. Try to keep the high frequency big current loop area small to minimize the EMI (electromagnetic interfacing).

### GROUNDING

A ground plane layer is important for the LTC854x circuit design. The length of the current path speed currents in an inductive ground return will create an unwanted voltage noise. Broad ground plane areas will reduce the parasitic inductance.

### INPUT-TO-OUTPUT COUPLING

To minimize capacitive coupling, the input and output signal traces should not be parallel. This helps reduce unwanted positive feedback.



Typical Application Circuits

DIFFERENTIAL AMPLIFIER

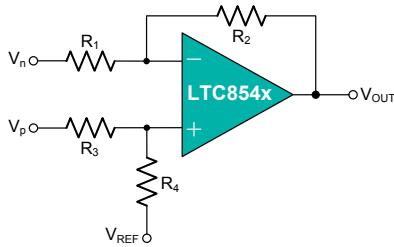

Figure 5. Differential Amplifier

The circuit shown in Figure 5 performs the difference function. If the resistor ratios are equal  $R_4/R_3 = R_2/R_1$ , then:

$$V_{OUT} = (V_p - V_n) \times R_2/R_1 + V_{REF}$$

INSTRUMENTATION AMPLIFIER

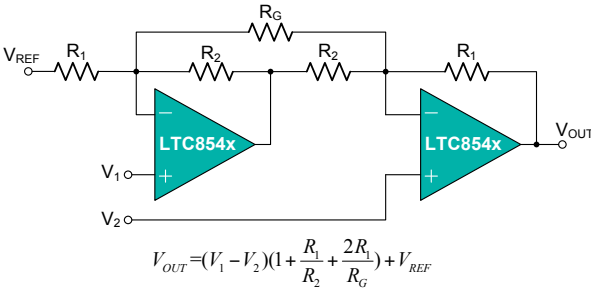
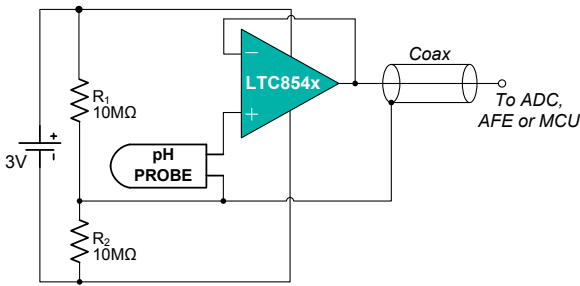

Figure 6. Instrumentation Amplifier

The LTC854x family is well suited for conditioning sensor signals in battery-powered applications. Figure 6 shows a two op-amp instrumentation amplifier, using the LTC854x op-amps. The circuit works well for applications requiring rejection of common-mode noise at higher gains. The reference voltage ( $V_{REF}$ ) is supplied by a low-impedance source. In single voltage supply applications, the  $V_{REF}$  is typically  $V_S/2$ .

BUFFERED CHEMICAL SENSORS



All components contained within the pH probe

Figure 7. Buffered pH Probe

The LTC854x family has input bias current in the pA range. This is ideal in buffering high impedance chemical sensors, such as pH probes. As an example, the circuit in Figure 7 eliminates expansive low-leakage cables that is required to connect a pH probe (general purpose combination pH probes, e.g Corning 476540) to metering ICs such as ADC, AFE and/or MCU. A LTC854x op-amp and a lithium battery are housed in the probe assembly. A conventional low-cost coaxial cable can be used to carry the op-amp's output signal to subsequent ICs for pH reading.

SHUNT-BASED CURRENT SENSING AMPLIFIER

The current sensing amplification shown in Figure 8 has a slew rate of  $2\pi V_{PP}$  for the output of sine wave signal, and has a slew rate of  $2V_{PP}$  for the output of triangular wave signal. In most of motor control systems, the PWM frequency is at 10kHz to 20kHz, and one cycle time is 100µs for a 10kHz of PWM frequency. In current shunt monitoring for a motor phase, the phase current is converted to a phase voltage signal for ADC sampling. This sampling voltage signal must be settled before entering the ADC. As the Figure 8 shown, the total settling time of a current shunt monitor circuit includes: the rising edge delay time ( $t_{SR}$ ) due to the op-amp's slew rate, and the measurement settling time ( $t_{SET}$ ). For a 3-shunt solution in motor phase current sensing, if the smaller duty cycle of the PWM is defined at 45% (In fact, the phase with minimum PWM duty cycle, such as 5%, is not detected current directly, and it can be calculated from the other two phase currents), and the  $t_{SR}$  is required at 20% of a total time window for a phase current monitoring, in case of a 3.3V motor control system (3.3V MCU with 12-bit ADC), the op-amp's slew rate should be more than:

$$3.3V / (100\mu s \times 45\% \times 20\%) = 0.37 V/\mu s$$

At the same time, the op-amp's bandwidth should be much greater than the PWM frequency, like 10 time at least.

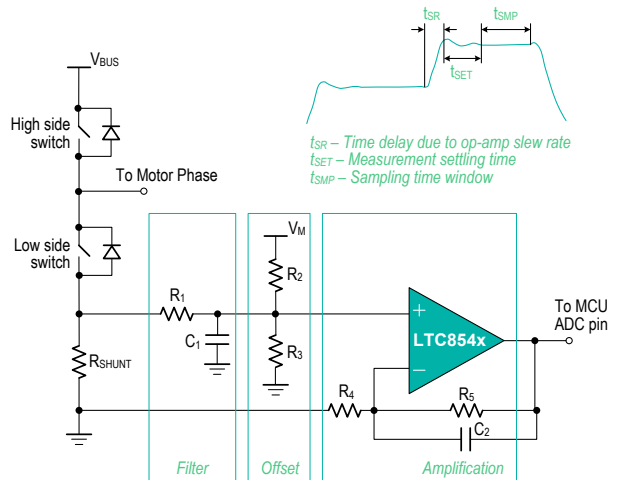

Figure 8. Current Shunt Monitor Circuit

# LTC8541, LTC8542, LTC8544

1.1MHz, 70µA, CMOS RRIO Operational Amplifiers

## Package Outlines

### SC70-5 (SOT353)

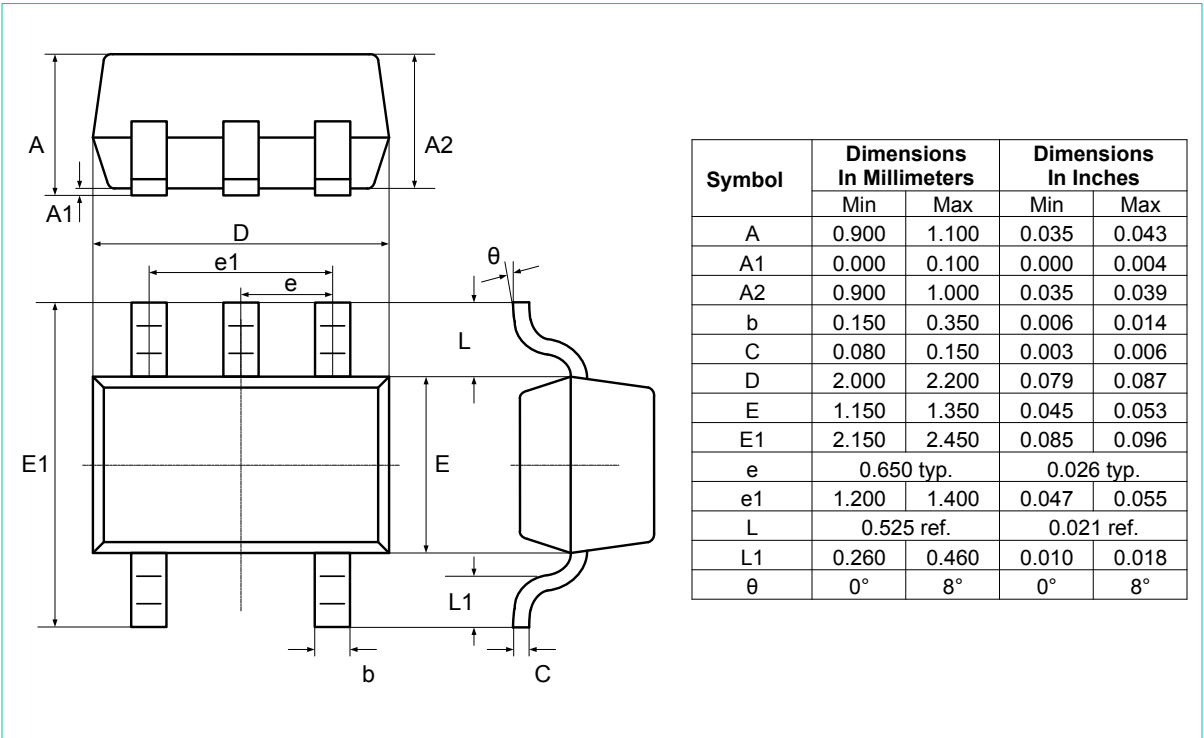

### SOT23-5

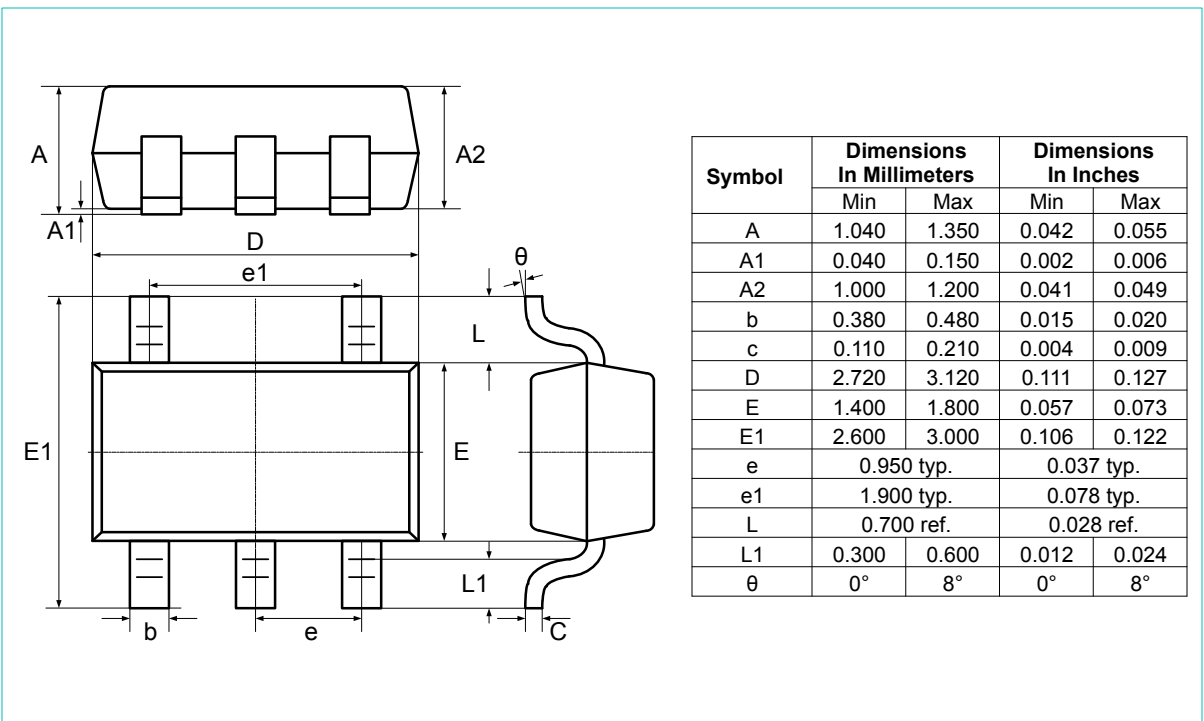

Package Outlines (continued)

DFN2x2-8L

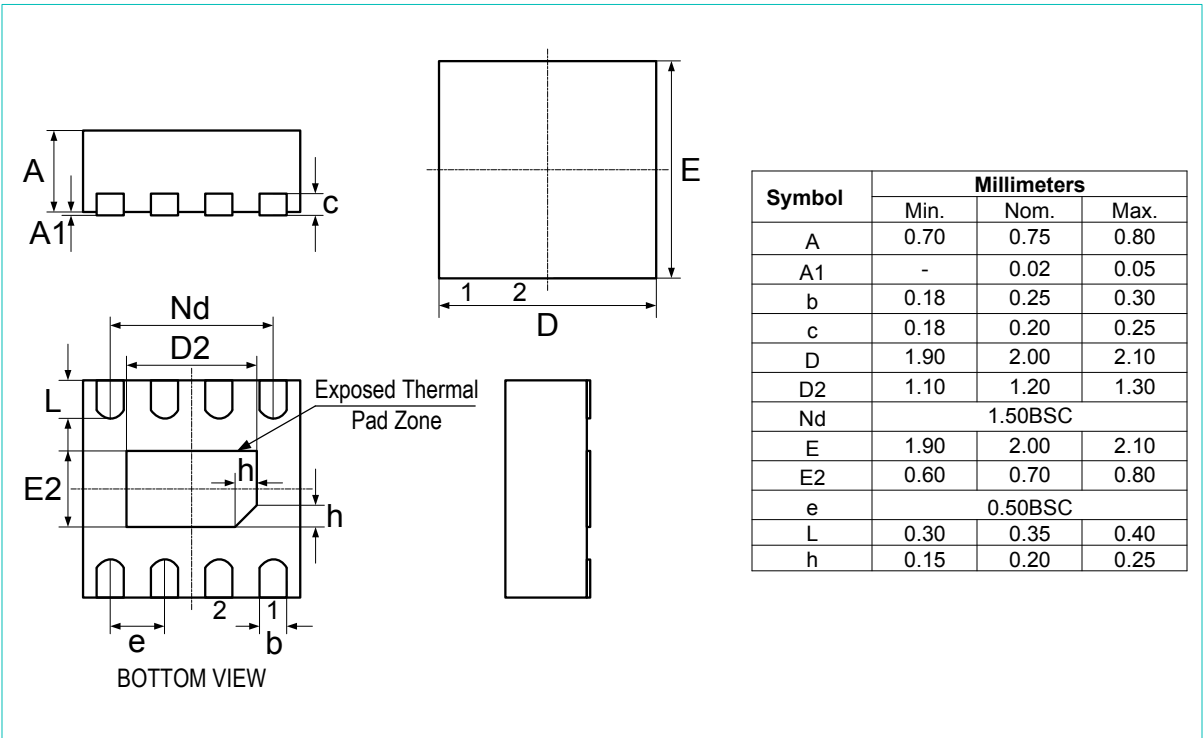

MSOP-8

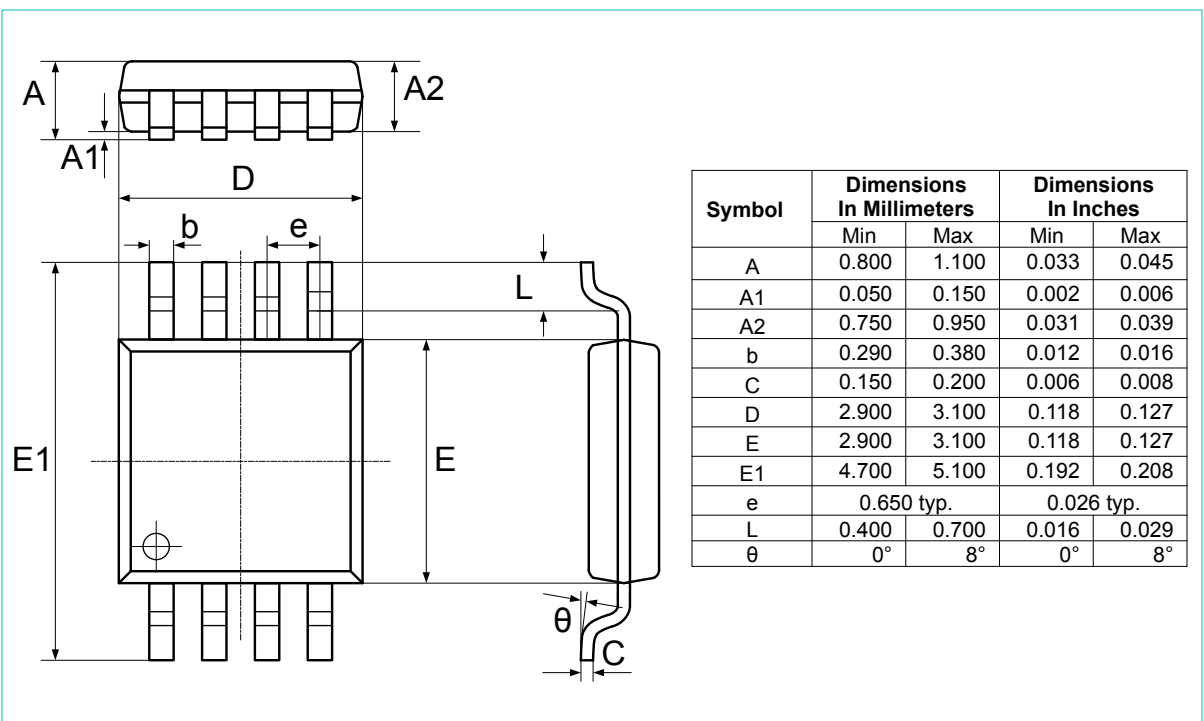

# LTC8541, LTC8542, LTC8544

1.1MHz, 70µA, CMOS RRIO Operational Amplifiers

## Package Outlines (continued)

### SO-8

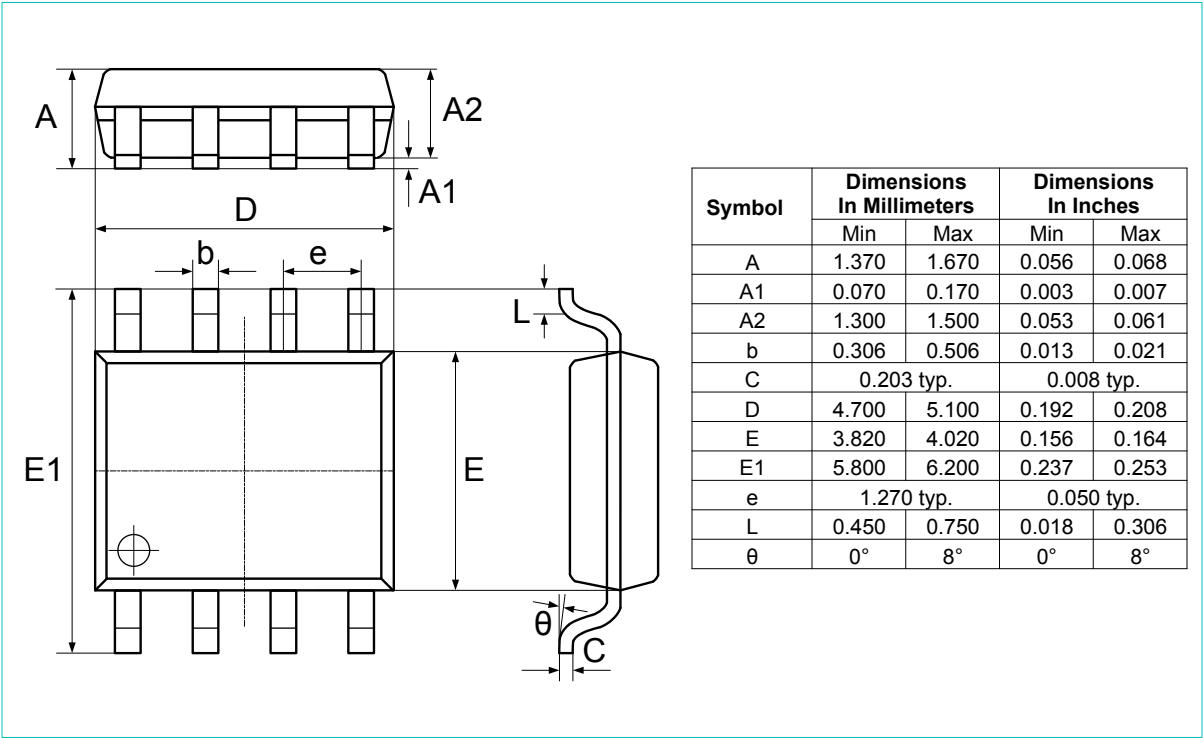

### TSSOP-14

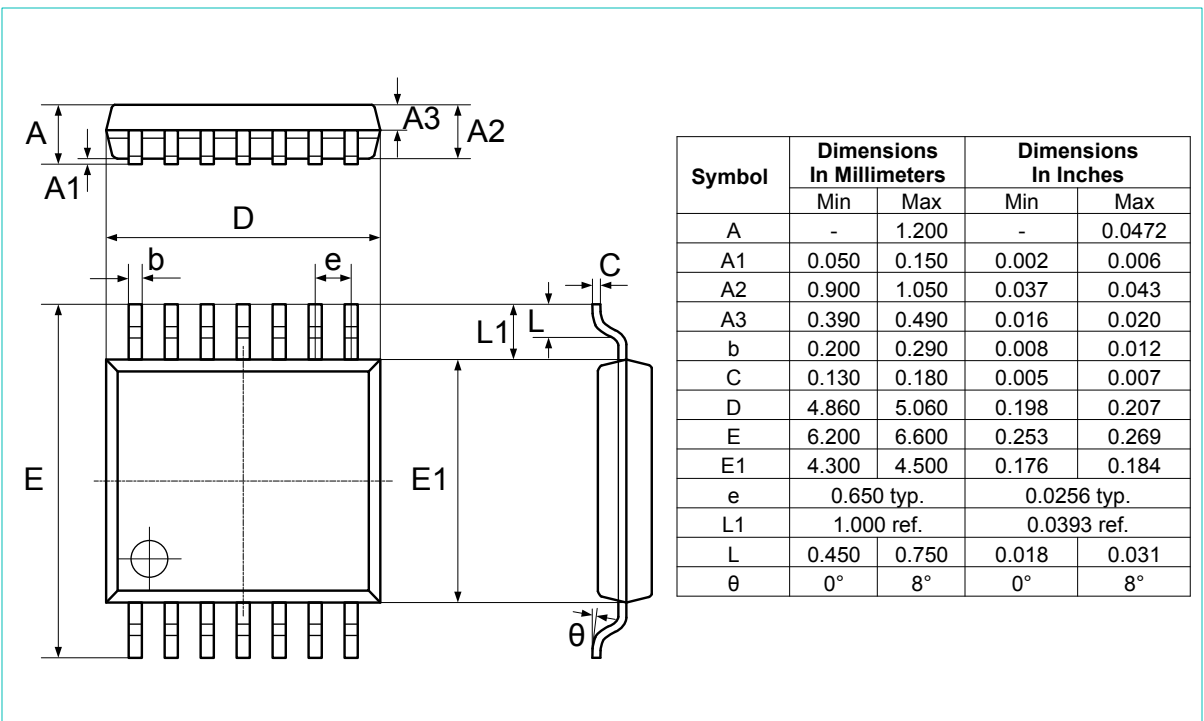

Package Outlines (continued)

SO14

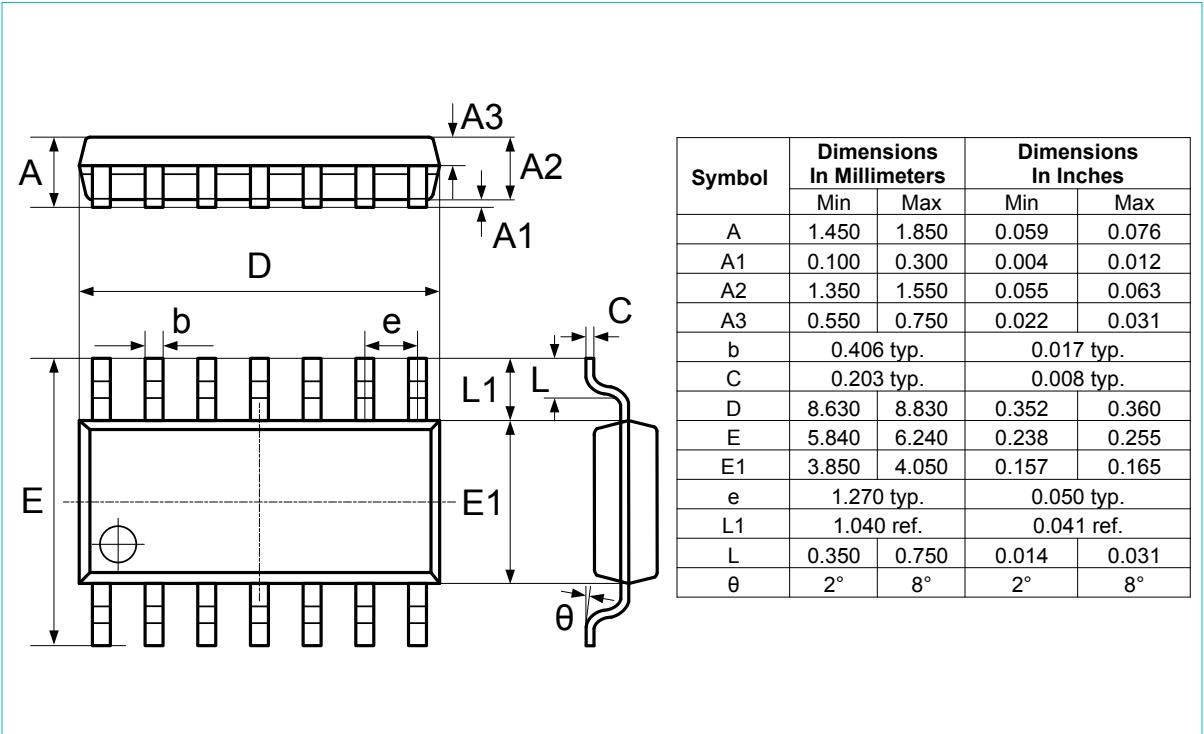

单击下面可查看定价，库存，交付和生命周期等信息

[>>Linearin](#)