

LY16 Series Data Sheet

Features

- RoHS Compliant & Halogen Free
- Faster Tripping
- Operating temperature: -40°C ~ +85°C
- Hold Current: 0.1A~14A
- Maximum Voltage: 16V

Applications

- Phone set and fax machine
- LAN/WAN and VOIP cards
- Central office equipment
- IT equipment

Part Number Code

LY16 - 010

LY16: Voltage Code, LY16 series, $V_{Max}=16V$

010: $I_{Hold}=0.1A$

Dimensions (Unit: mm)

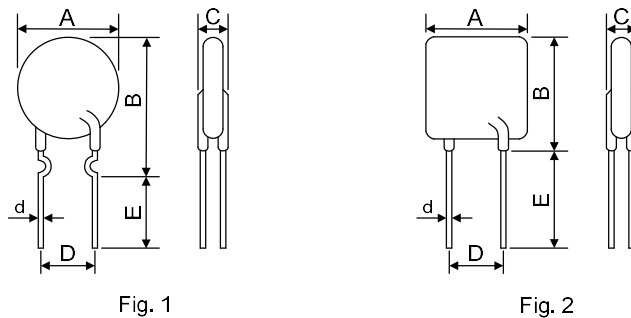

Model	A(Max.)	B(Max.)	C(Max.)	D(± 0.75)	E(Min.)	d(Typ.)	Shape
LY16-010	5.5	12.0	3.0	5.1	4.6	0.5	Fig. 1
LY16-025	5.5	12.0	3.0	5.1	4.6	0.5	Fig. 1
LY16-030	5.5	12.0	3.0	5.1	4.6	0.5	Fig. 1
LY16-050	5.5	12.0	3.0	5.1	4.6	0.5	Fig. 1
LY16-075	7.4	13.5	3.0	5.1	4.6	0.5	Fig. 1
LY16-090	7.4	13.5	3.0	5.1	4.6	0.5	Fig. 1
LY16-110	7.4	13.5	3.0	5.1	4.6	0.5	Fig. 1
LY16-135	7.4	13.5	3.0	5.1	4.6	0.5	Fig. 1
LY16-160	7.4	14.0	3.0	5.1	4.6	0.5	Fig. 1

Model	A(Max.)	B(Max.)	C(Max.)	D(± 0.75)	E(Min.)	d(Typ.)	Shape
LY16-200	9.0	12.0	3.0	5.1	7.6	0.5	Fig. 2
LY16-300	9.0	12.0	3.0	5.1	7.6	0.8	Fig. 2
LY16-400	10.0	13.0	3.0	5.1	7.6	0.8	Fig. 2
LY16-500	11.8	17.5	3.0	5.1	7.6	0.8	Fig. 2
LY16-600	13.5	17.5	3.0	5.1	7.6	0.8	Fig. 2
LY16-700	13.5	23.0	3.0	5.1	7.6	0.8	Fig. 2
LY16-800	13.5	23.0	3.0	5.1	7.6	0.8	Fig. 2
LY16-900	15.0	24.0	3.0	5.1	7.6	0.8	Fig. 2
LY16-1000	18.0	26.0	3.0	5.1	7.6	0.8	Fig. 2
LY16-1100	18.0	26.0	3.0	5.1	7.6	0.8	Fig. 2
LY16-1200	22.5	26.0	3.0	10.2	7.6	0.8	Fig. 2
LY16-1300	24.0	30.0	3.0	10.2	7.6	0.8	Fig. 2
LY16-1400	24.0	30.0	3.0	10.2	7.6	0.8	Fig. 2

Electrical Characteristics

Model	I_{Hold}	I_{Trip}	V_{Max}	I_{Max}	P_d Typ.	Maximum time to trip		Resistenct	
	(A)	(A)	(V_{DC})	(A)	(W)	Current(A)	Time(Sec)	$R_{Min}(\Omega)$	$R_{Max}(\Omega)$
LY16-010	0.1	0.3	16	100	0.38	0.5	5	1.50	7.50
LY16-025	0.25	0.5	16	100	0.45	1.25	5	0.50	1.95
LY16-030	0.3	0.6	16	100	0.49	1.5	5	0.30	0.70
LY16-050	0.5	1.0	16	100	0.56	2.5	5	0.20	0.50
LY16-075	0.75	1.5	16	100	0.72	3.75	5	0.10	0.32
LY16-090	0.9	1.8	16	100	0.83	4.5	5	0.09	0.18
LY16-110	1.1	2.2	16	100	0.94	5.5	5	0.06	0.15
LY16-135	1.35	2.7	16	100	1.20	6.75	5	0.04	0.13
LY16-160	1.6	3.2	16	100	1.40	8.0	5	0.04	0.11
LY16-200	2.0	4.0	16	100	2.20	6.0	15	0.035	0.075
LY16-300	3.0	6.0	16	100	2.30	9.0	15	0.02	0.06
LY16-400	4.0	8.0	16	100	2.40	12.0	15	0.02	0.04
LY16-500	5.0	10.0	16	100	2.60	15.0	15	0.014	0.025
LY16-600	6.0	12.0	16	100	2.80	18.0	15	0.01	0.021
LY16-700	7.0	14.0	16	100	3.00	21.0	15	0.008	0.015
LY16-800	8.0	16.0	16	100	3.00	24.0	15	0.006	0.013
LY16-900	9.0	18.0	16	100	3.30	27.0	25	0.004	0.012
LY16-1000	10.0	20.0	16	100	3.70	30.0	30	0.004	0.011
LY16-1100	11.0	22.0	16	100	3.70	33.0	30	0.003	0.009

Model	I_{Hold}	I_{Trip}	V_{Max}	I_{Max}	$P_{d Typ.}$	Maximum time to trip		Resistenct	
	(A)	(A)	(V)	(A)	(W)	Current(A)	Time(Sec)	$R_{Min}(\Omega)$	$R_{Max}(\Omega)$
LY16-1200	12.0	24.0	16	100	4.20	36.0	30	0.003	0.008
LY16-1300	13.0	26.0	16	100	4.20	39.0	50	0.003	0.008
LY16-1400	14.0	28.0	16	100	4.20	40.0	50	0.003	0.007

- ◆ I_{Hold} =Hold Current. Maximum current device will not trip in 25°C still air.
- ◆ I_{Trip} =Trip Current. Minimum current at which the device will always trip in 25°C still air.
- ◆ V_{Max} =Maximum operating voltage device can withstand without damage at rated current (I_{Max}).
- ◆ I_{Max} =Maximum fault current device can withstand without damage at rated voltage (V_{Max}).
- ◆ $P_{d Typ.}$ =Typical power dissipation when device is in the tripped state in 25°C still air environment at rated voltage.
- ◆ R_{Min} =Minimum resistance of device in initial (un-soldered) state at 25°C.
- ◆ R_{Max} =Maximum resistance of device in initial (un-soldered) state at 25°C.

Thermal Derating Chart- I_H (A)

Model	Maximum ambient operating temperature									
	-40°C	-20°C	0°C	25°C	30°C	40°C	50°C	60°C	70°C	85°C
LY16-010	0.15	0.13	0.12	0.10	0.09	0.09	0.08	0.07	0.06	0.05
LY16-025	0.37	0.33	0.30	0.25	0.23	0.22	0.20	0.18	0.15	0.12
LY16-030	0.44	0.40	0.36	0.30	0.27	0.26	0.24	0.21	0.18	0.14
LY16-050	0.74	0.66	0.60	0.50	0.45	0.44	0.40	0.36	0.31	0.24
LY16-075	1.10	0.99	0.90	0.75	0.68	0.66	0.60	0.53	0.46	0.35
LY16-090	1.32	1.19	1.08	0.90	0.81	0.79	0.72	0.64	0.55	0.42
LY16-110	1.62	1.45	1.32	1.10	0.99	0.97	0.88	0.78	0.67	0.52
LY16-135	1.98	1.78	1.62	1.35	1.22	1.19	1.08	0.96	0.82	0.63
LY16-160	2.35	2.11	1.92	1.60	1.44	1.41	1.28	1.14	0.98	0.75
LY16-200	2.94	2.64	2.40	2.00	1.80	1.76	1.60	1.42	1.22	0.94
LY16-300	4.41	3.96	3.60	3.00	2.70	2.64	2.40	2.13	1.83	1.41
LY16-400	5.88	5.28	4.80	4.00	3.60	3.52	3.20	2.84	2.44	1.88
LY16-500	7.35	6.60	6.00	5.00	4.50	4.40	4.00	3.55	3.05	2.35
LY16-600	8.82	7.92	7.20	6.00	5.40	5.28	4.80	4.26	3.66	2.82
LY16-700	10.29	9.24	8.40	7.00	6.30	6.16	5.60	4.97	4.27	3.29
LY16-800	11.76	10.56	9.60	8.00	7.20	7.04	6.40	5.68	4.88	3.76
LY16-900	13.23	11.88	10.80	9.00	8.10	7.92	7.20	6.39	5.49	4.23
LY16-1000	14.70	13.20	12.00	10.00	9.00	8.80	8.00	7.10	6.10	4.70
LY16-1100	16.17	14.52	13.20	11.00	9.90	9.68	8.80	7.81	6.71	5.17
LY16-1200	17.64	15.84	14.40	12.00	10.80	10.56	9.60	8.52	7.32	5.64
LY16-1300	19.11	17.16	15.60	13.00	11.70	11.44	10.40	9.23	7.93	6.11
LY16-1400	20.58	18.48	16.80	14.00	12.60	12.32	11.20	9.94	8.54	6.58

Environmental Specifications

Test	Conditions	Resistance Change
Passive aging	+85°C, 1000 hours	≤R _{Max}
Humidity aging	+85°C/85%R.H., 1000 hours	≤R _{Max}
Thermal shock	-55°C to +125°C, 10 times	≥R _{Min}
Solvent Resistance	MIL-STD-202, Method 215F	No change
Vibration	MIL-STD-202, Method 201	No change

Soldering

Wave Soldering	
Soldering Temperature	245°C~260°C
Soldering Time	≤5 seconds
Soldering Position	PPTC lead and the distance from the bottom ≥ 6mm
Manual Soldering	
Soldering Temperature	250°C~280°C
Soldering Time	≤3 seconds
Soldering Position	PPTC lead and the distance from the bottom ≥ 6mm

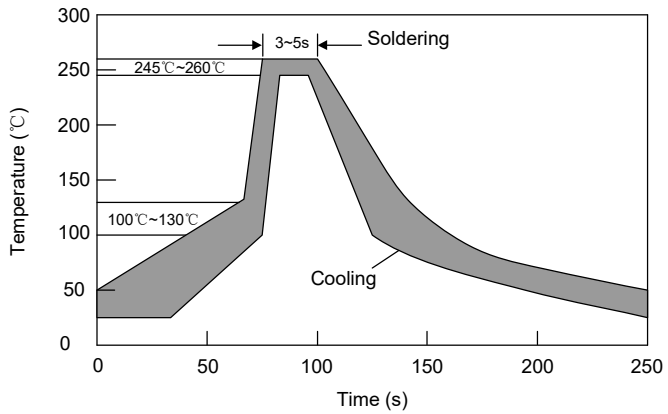

Packaging Quantity

Model	Quantity
LY16-010~LY16-600	1000pcs/bag
LY16-700~LY16-900	500pcs/bag
LY16-1000~LY16-1400	200pcs/bag

Storage

The maximum ambient temperature shall not exceed 40°C. Storage temperatures higher than 40°C could result in the deformation of packaging materials. The maximum relative humidity recommended for storage is 70%. High humidity with high temperature can accelerate the oxidation of the solder plating on the leads and reduce the solderability of the components. Sealed plastic bags with desiccant shall be used to reduce the oxidation of the leads and shall only be opened prior to use. The products shall not be stored in areas where harmful gases containing acid or alkali or other harmful substances are present.

Warning

- ✦ Use PPTC beyond the maximum ratings or improper use may result in device damage, electrical arcing and flame.
- ✦ PPTC are intended for protection against occasional over current or over temperature fault conditions and should not be used when repeated fault conditions or prolonged trip events are anticipated.
- ✦ Device performance can be impacted negatively if devices are handled in a manner inconsistent with recommended electronic, thermal, and mechanical procedures for electronic components.
- ✦ Use PPTC with a large inductance in circuit will generate a circuit voltage above the rated voltage of the PPTC.
- ✦ Avoid impact PPTC device its thermal expansion like placed under pressure or installed in limited space.
- ✦ Contamination of the PPTC material with certain silicon based oils or some aggressive solvents can adversely impact the performance of the devices. PPTC can be cleaned by standard methods.

单击下面可查看定价，库存，交付和生命周期等信息

[>>Liown\(里阳半导体\)](#)