



Optical Sensor
Product Data Sheet
LTR-2568ALS-01

Spec No. :DS86-2018-0028
Effective Date: 03/09/2019
Revision: A

LITE-ON DCC

RELEASE

BNS-OD-FC001/A4

OPTICAL SENSOR LTR-2568ALS-01

Description

The LTR-2568ALS-01 is an integrated low voltage I2C ambient light sensor (ALS), and proximity sensor (PS), with built-in emitter in a single miniature chipled lead-free surface mount package.

The ALS provides a linear response over a wide dynamic range, which is well suited to applications under very low or bright ambient brightness. Besides, with built-in proximity sensor, this sensor offers the feature to detect object at a user configurable distance.

The sensor has a programmable interrupt with hysteresis to respond to events and that removes the need to poll the sensor for a reading which improves system efficiency. This CMOS design and factory-set one time trimming capability ensures minimal sensor-to-sensor variations for ease of manufacturability to the end customers.

Application

- Control brightness of display panel
- Object detection in mobile, computing, and consumer devices.

Features

- I²C interface (Standard mode @100kHz or Fast mode @400kHz)
- Ambient Light and Proximity Sensing in one ultra-small ChipLED package
- Very low power consumption with sleep mode capability
- Operating voltage ranges: 1.7V to 3.6V
- Operating temperature ranges: -30 to +85 °C
- Programmable interrupt function for ALS and PS with upper and lower thresholds
- RoHS and Halogen free compliant

ALS Features

- 16 bits effective resolution
- Wide dynamic range with linear response
- Close to human eye spectral response
- Automatic rejection for 50Hz/60Hz lighting flicker

PS Features

- Built-in Vcsel LED driver
- High ambient light suppression
- 16-bit effective resolution
- 11-bit or 16-bit display
- Cancellation of crosstalk
- Programmable Vcsel LED drive setting
- Ambient IR saturation indicator

Ordering Information

Part Number	Packaging Type	Package	Quantity
LTR-2568ALS-01	Tape and Reel	8-pin chipled package	4000pcs

**OPTICAL SENSOR
LTR-2568ALS-01**

1. Outline Dimensions and Pins Configuration

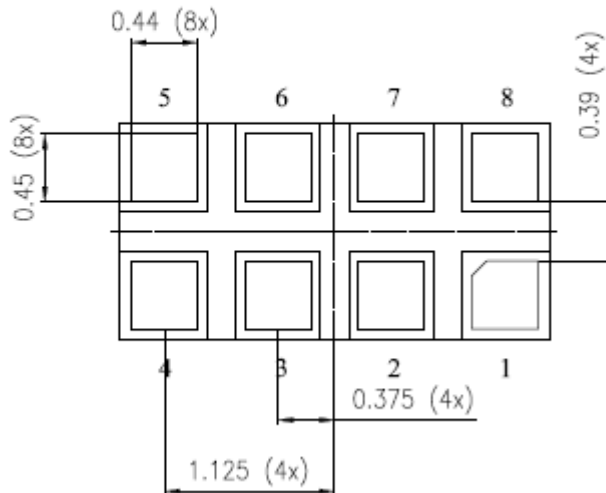
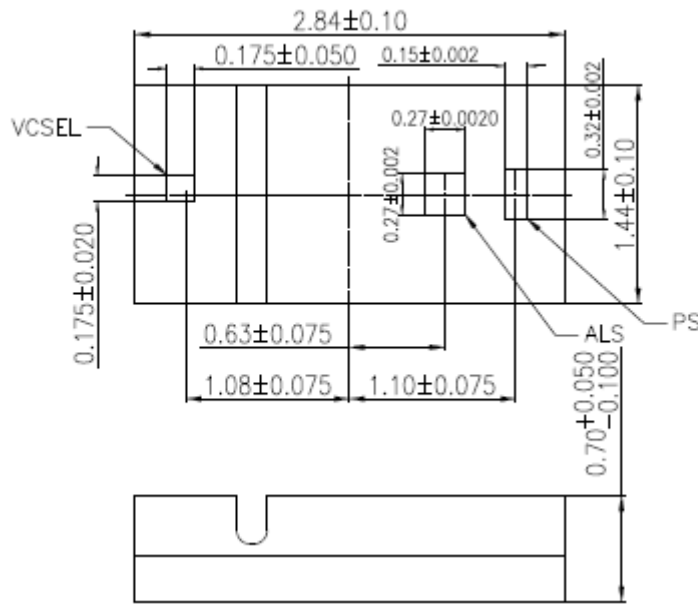

Pin-Out Assignment:

- | | |
|---------|--------|
| 1. SCL | 5. NC |
| 2. VSS | 6. VDD |
| 3. PGND | 7. INT |
| 4. LEDA | 8. SDA |

Note: All dimensions in millimeter

OPTICAL SENSOR LTR-2568ALS-01

2. Functional Block Diagram

The LTR-2568ALS-01 contains 2 integrated photodiodes (1 for proximity diode, 1 diodes for ambient diode) for respective photocurrent measurement. The photodiode currents are converted to digital values by ADCs. The sensor also includes a LED driver, as well as some peripheral circuits such as an internal oscillator, a current course, voltage reference, and internal fuses to store trimming information.

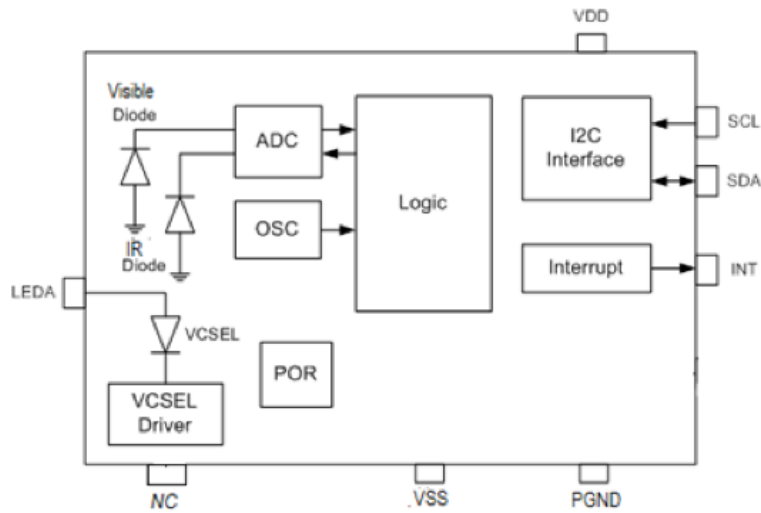

OPTICAL SENSOR LTR-2568ALS-01

3. Application Circuit

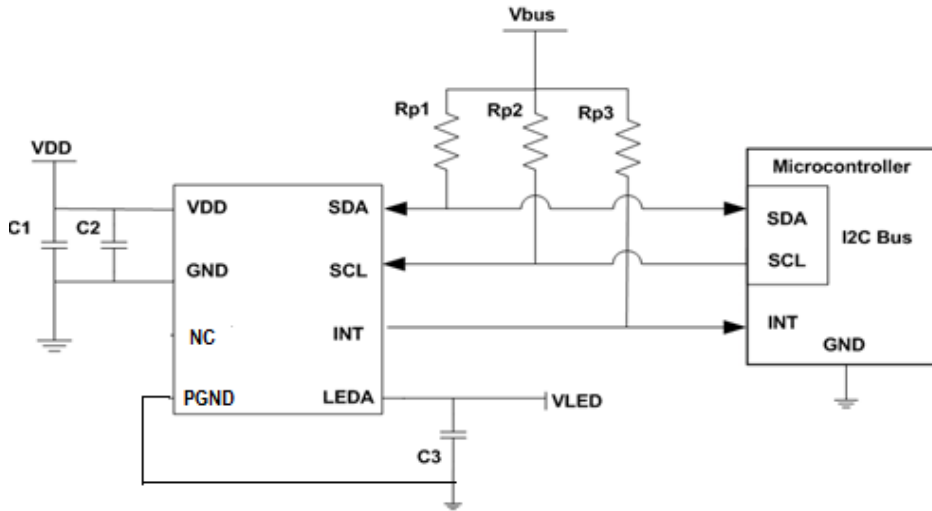

Note: It is a requirement to separate the VDD and VLED

I/O Pins Configuration Table

Pin	I/O Type	Symbol	Description
1	IN	SCL	I ² C serial clock
2	GND	GND	GND. All voltages are referenced to PGND/GND and both pins must
3	GND	PGND	connected to ground
4	Supply	LEDA	LED Anode. Connect to VBAT on PCB
5	NC	NC	No Connect
6	Supply	VDD	Supply Voltage
7	Out	INT	Interrupt pin
8	IN/OUT	SDA	I ² C serial data

Recommended Application Circuit Components

Component	Recommended Value
Rp1, Rp2, Rp3 [1]	1 kΩ to 10 kΩ
C1, C3	1μF ±20%, X7R / X5R Ceramic
C2	0.1μF

[1] Selection of pull-up resistors value is dependent on bus capacitance values. For more details, please refer to I²C Specifications: http://www.nxp.com/documents/user_manual/UM10204.pdf

OPTICAL SENSOR LTR-2568ALS-01

4. Ratings and Specifications

Absolute Maximum Ratings at Ta = 25°C

Parameter	Symbol	Min.	Max	Unit
Supply Voltage	VDD		4.5	V
Digital Voltage Range	SCL, SDA, INT	-0.5	4.5	V
Max Voltage Range	LDR	-0.5	4.5	V
Storage Temperature	T _{stg}	-40	85	°C
Electrostatic Discharge Protection (Human Body Model JESD22-A114)	V _{HBM}	2000		V
Electrostatic Discharge Protection (Charge Device Model)	V _{CDM}	500		V
Electrostatic Discharge Protection (Ref:JESD78A,1.5x VDD Max)	Latch up	100		mA
EMI/EMC Immunity	Direct injection @VDD pin	15		dBm
	Direct injection @ I2C pins	10		dBm
	Radiated immunity	10000		V/m

Note: Exceeding these ratings could cause damage to the sensor. All voltages are with respect to ground. Currents are positive into, negative out of the specified terminal.

Recommended Operating Conditions

Description	Symbol	Min.	Typ.	Max.	Unit
Supply Voltage	VDD	1.7		3.6	V
LED Supply Voltage	V _{LED}	2.8		4.35	V
Interface signal input high	V _{I2Chigh}	1.5		VDD	V
Power on reset(POR)	T _{POR}			400	ms
Interface signal input low	V _{I2Clow}	0		0.4	V
Operating Temperature	T _{ope}	-30		85	°C

Part No. : LTR-2568ALS-01
BNS-

OPTICAL SENSOR LTR-2568ALS-01

Electrical & Optical Specifications

All specifications are at VDD = 3.0 V, T_{ope} = 25°C, unless otherwise noted.

Parameter	Min.	Typ.	Max.	Unit	Condition
Average Current consumption including VDD and VLEDA			2	mA	VCSEL LED turn on and PS active mode
Ave Current consumption(ALS)			300	uA	1.8V, ALS active, 100ms Int time
PS Active Supply Current		120	200	uA	100 ms MRR , 32 pulse 100% duty
Standby Current			5	uA	Shutdown Mode
Wakeup Time from Standby		5	10	ms	From Standby to Active mode where measurement can start

Characteristics Ambient Light Sensor

Parameter	Min.	Typ.	Max.	Unit	Condition
ALS Resolution			16	Bit	Programmable for 13, 14, 15, 16 Bit
ALS Lux accuracy	-15		15	%	Across different light sources
ALS FOV	100		104	°	Full Angle
Sensitivity			0.008	Lux/step	Gain 64, 100ms Integration time
ALS count part to part	-15		15	%	
ALS ADC count stability	-1		1	%	Max-min
Dark Level Count			2	Count	0 Lux, 16-bit resolution, Gain64, 100ms integration time
Integration time	50		400	ms	With 50/60Hz Rejection
50/60 Hz flicker noise error	-5		+5	%	

OPTICAL SENSOR LTR-2568ALS-01

Characteristics Proximity Sensor & Vcsel LED

Parameter	Min.	Typ.	Max.	Unit	Condition
Effective PS Resolution			16	Bit	Configurable to 11 bit display (capped at 2047) or 16 bit
Note 1					
Sensitivity Range		940		nm	
Detection Distance		10		cm	32 pulse, 32us, 9mA
Pdata3-CT part to part variation*	362	426	490	count	Target grey card 18% at 3cm
Pdata5-CT part to part variation	130	153	176	count	Target grey card 18% at 5cm
Delta 3cm-5cm part to part variation	232	273	314	count	Pdata3-Pdata5
Pdata5-CT/Noise	5				Target grey card 18%
VCSEL beam divergence	7	10	13	°	Full width
CT(crosstalk)			10	%FS	PS ADC 16 bit, open air and offset = 0
Noise			3	%FS	Max-min, open air and no averaging
LED Pulse Current			9	mA	
LED Pulse width			32	us	Configurable for 4,8,16,32 us
LED Duty Cycle		100		%	
Number of LED Pulses	1		64	Pulses	Programmable from 1 to 64 pulses
Ambient light suppression **			100	klux	Direct sunlight
100klux Sunlight suppression**		Pdata_5			>100k sunlight IR content

Note1: Internal IC ADC resolution is 16 bits.

** Above 50klux, internal fail-safe feature will force PS count to zero to prevent false trigger.

**OPTICAL SENSOR
LTR-2568ALS-01**

Typical Device Parameter

(VDD = 2.8V, Ta=25°C, Default power-up settings, unless otherwise noted)

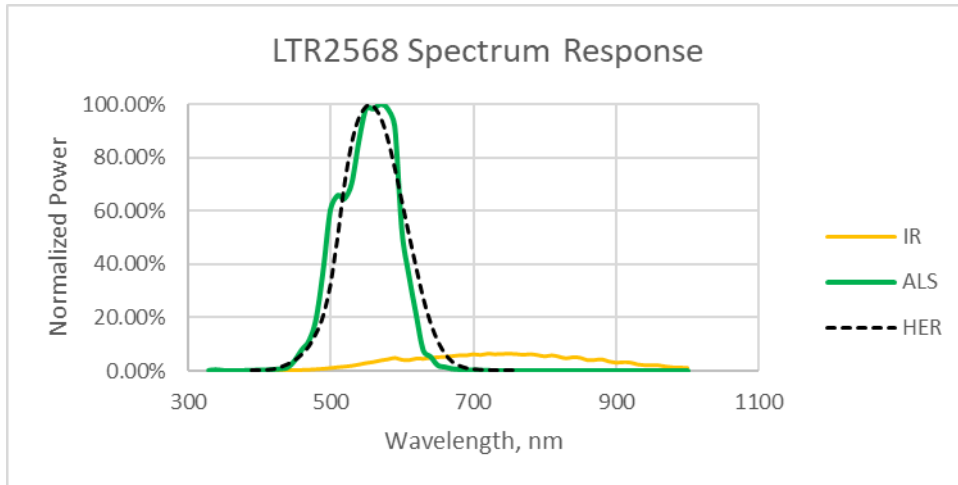

Figure 4.1 : ALS Spectral response



Figure 4.2: PS performance across distance VDD 3V, 9mA, 32pulses, with others in default settings.

**OPTICAL SENSOR
LTR-2568ALS-01**

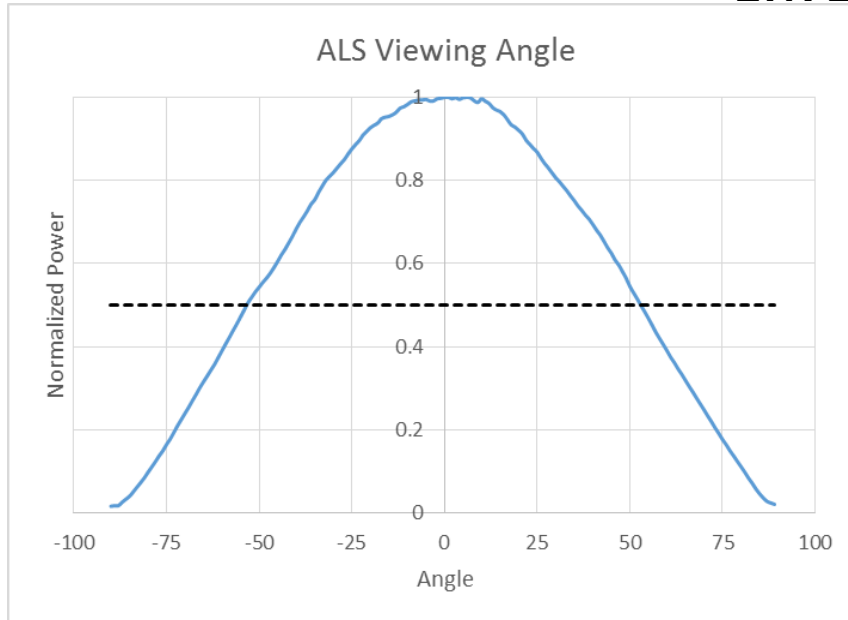

Figure 4.3: ALS viewing angle performance

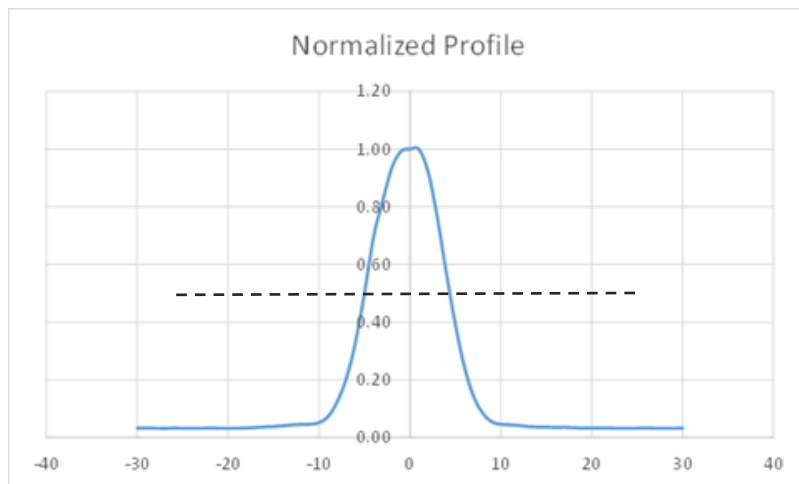

Figure 4.4 Emitter Viewing angle

OPTICAL SENSOR LTR-2568ALS-01

AC Electrical Characteristics

All specifications are at VBus = 1.7V, T_{ope} = 25°C, unless otherwise noted.

Parameter	Symbol	Standard mode		Fast mode		Unit
		Min.	Max.	Min.	Max.	
SCL clock frequency	f_{SCL}	100		400		kHz
Bus free time between a STOP and START condition	t_{BUF}	4.7	-	1.3	-	us
Hold time (repeated) START condition. After this period, the first clock pulse is generated	$t_{HD,STA}$	4.0	-	0.6	-	us
LOW period of the SCL clock	t_{LOW}	4.7	-	1.3	-	us
HIGH period of the SCL clock	t_{HIGH}	4.0	-	0.6	-	us
Set-up time for a repeated START condition	$t_{SU,STA}$	4.7	-	0.6	-	us
Set-up time for STOP condition	$t_{SU,STO}$	4.0	-	0.6	-	us
Rise time of both SDA and SCL signals	t_r	-	1000	-	300	ns
Fall time of both SDA and SCL signals	t_f	-	300	-	300	ns
Data hold time	$t_{HD,DAT}$	0	-	0	-	us
Data setup time	$t_{SU,DAT}$	250	-	100	-	ns

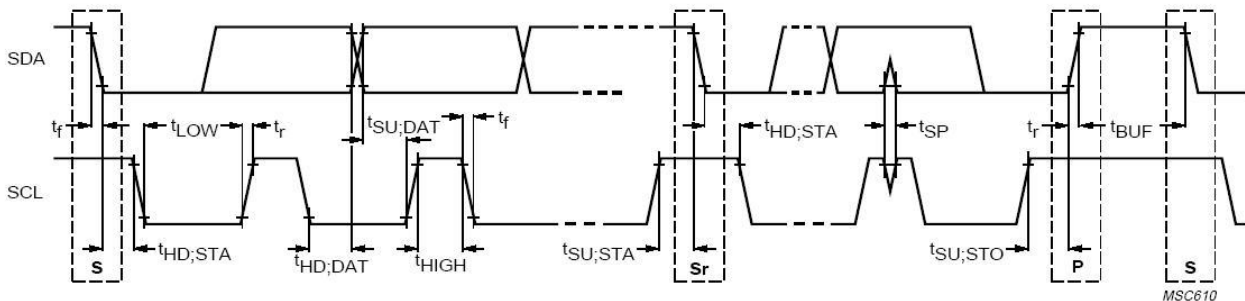

Definition of timing for I²C bus

OPTICAL SENSOR LTR-2568ALS-01

5. Principles of Operation

I²C Protocols

• I²C Write Protocol (type 1):

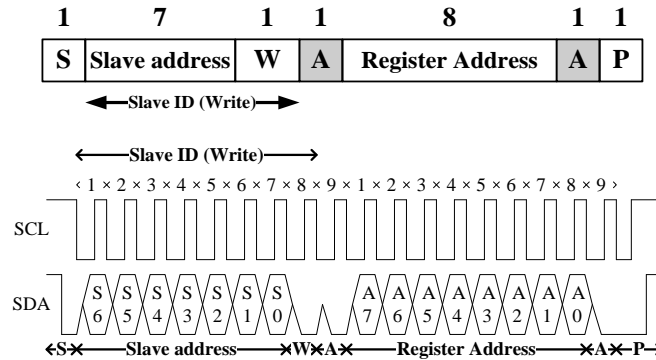

• I²C Write Protocol (type 2):

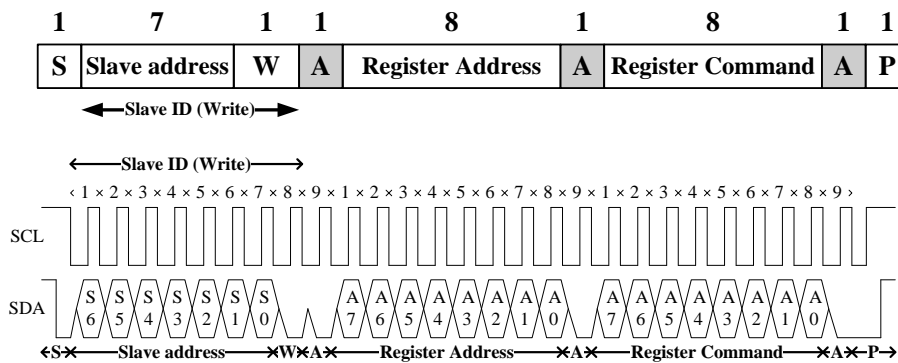

• I²C Read Protocol:

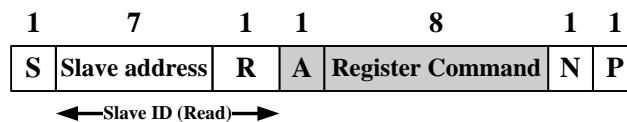

OPTICAL SENSOR LTR-2568ALS-01

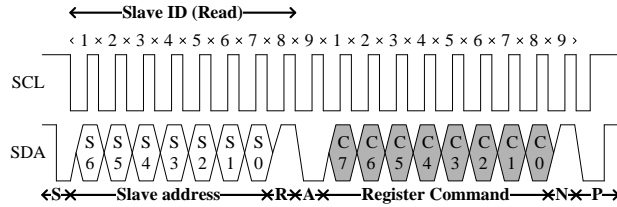

• I²C Read (Combined format) Protocol:

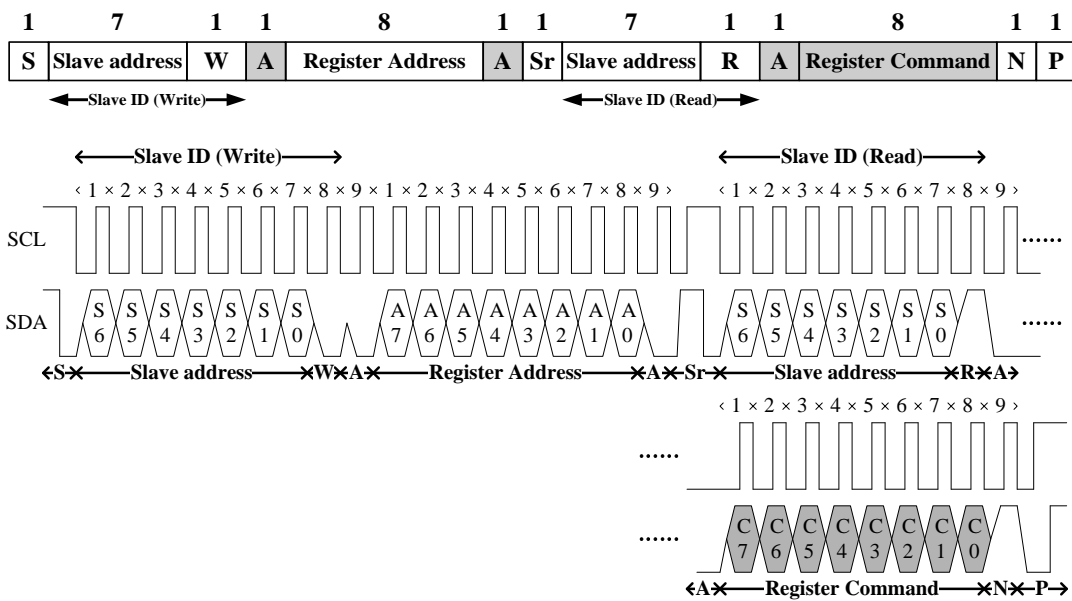

A Acknowledge (0 for an ACK)

S Start condition

P Stop condition

W Write (0 for writing)

Slave-to-master

N Non-Acknowledge(1 for an NACK)

Sr Repeated Start condition

R Read (1 for read)

Master-to-Slave

OPTICAL SENSOR LTR-2568ALS-01

I2C Slave Address

The 7 bits slave address for this sensor is 0x23H. A read/write bit should be appended to the slave address by the master device to properly communicate with the sensor.

I ² C Slave Address									
Command Type	(0x23H)							(0x23H)	(0x23H)
	Bit7	Bit6	Bit5	Bit4	Bit3	Bit2	Bit1	Bit0	
Write	0	1	0	0	0	1	1	0	0x46H
Read	0	1	0	0	0	1	1	1	0x47H

6. Register Set

Address	R / W	Register Name	Description	Reset Value
0x7F	RW	ALS_CONFIG	ALS_CONFIG	0x07
0x80	RW	ALS_CONTR	ALS operation mode control	0x20
0x81	RW	PS_CONTR	PS operation mode control/SW Reset	0x10
0x82	RW	PS_LED	PS LED setting	0x7A
0x83	RW	PS_N_PULSES	PS number of pulses	0x00
0x84	RW	PS_MEAS_RATE	PS measurement rate in active mode	0x04
0x85	RW	ALS_INT_TIME	ALS integration time and measurement rate in active mode	0x06
0x86	R	PART_ID	Part Number ID and revision IDs	0x1C
0x87	R	MANUFAC_ID	Manufacturer ID	0x05
0x88	R	ALS_STATUS	ALS Status	0x00
0x89	R	IR_DATA_LSB	ALS measurement IR data, LSB	0x00
0x8A	R	IR_DATA_MSB	ALS measurement IR data, MSB	0x00
0x8B	R	ALS_DATA_LSB	ALS measurement data, LSB	0x00
0x8C	R	ALS_DATA_MSB	ALS measurement data, MSB	0x00
0x91	R	PS_STATUS	PS Status	0x08
0x92	R	PS_DATA	PS measurement data, LSB	0x00
0x93	R	PS_DATA	PS measurement data, MSB	0x00
0x94	R	PS_SAR	PS SAR value	0x00

**OPTICAL SENSOR
LTR-2568ALS-01**

0x95	R	ALS_SAR	ALS SAR value	0x00
0x98	RW	INTERRUPT	Interrupt settings	0x08
0x99	RW	INTERRUPT_PERSIST	PS and ALS interrupt persist setting	0x00
0x9A	RW	PS_THRES_HIGH_LSB	PS interrupt upper threshold, LSB	0xFF
0x9B	RW	PS_THRES_HIGH_MSB	PS interrupt upper threshold, MSB	0xFF
0x9C	RW	PS_THRES_LOW_LSB	PS interrupt lower threshold, LSB	0x00
0x9D	RW	PS_THRES_LOW_MSB	PS interrupt lower threshold, MSB	0x00
0x9E	RW	PXTALK_LSB	Xtalk correction on PS CH0 PD, LSB	0x00
0x9F	RW	PXTALK_MSB	Xtalk correction on PS CH0 PD, MSB	0x00
0xA4	RW	LED_DRIVE	LED driver Register	0x00
0xB6	RW	IR AMBIENT THRESHOLD	IR Ambient saturation threshold value	0x08
0xB7	RW	DSS_CONTR	Dynamic Sunlight Suppression control	0x40
0xAD	RW	MAIN_CONTR	Main Control Setting	0x00
0xB9	R	DARK_CONFIG	Dark Offset Map Value	0x00

OPTICAL SENSOR LTR-2568ALS-01

ALS CONFIG Register (0x7F) (Read/Write)

0x7F	ALS CONFIG Register (default = 0x07)							
	Bit 7	Bit 6	Bit 5	Bit 4	Bit 3	Bit 2	Bit 1	Bit 0
	<i>Reserved</i>							

Field	Bits	Default	Description
Reserved	7:0	0000 0111	Must write as 0000 0000

ALS_CONTR Register (0x80) (Read/Write)

The ALS_CONTR register controls the ALS operation modes for the sensor. The ALS sensor can be set to either standby mode or active mode. At either of these modes, the I2C circuitry is always active. The default mode after power up is standby mode. During standby mode, there is no ALS measurement performed but I2C communication is allowed to enable read/write to all the registers. **Register 0xAD must be set to 0x18 and register 0x7F must be set to 0x00 before enabling ALS.**

0x80	ALS_CONTR (default = 0x20)							
	Bit 7	Bit 6	Bit 5	Bit 4	Bit 3	Bit 2	Bit 1	Bit 0
	<i>ALS resolution</i>		<i>Reserved</i>		<i>ALS_Gain</i>		<i>ALS_SAR _ENB</i>	<i>ALS Mode</i>

Field	Bits	Default	Description	
ALS_Resolution	7:6	00	00	16Bits Integration (default)
			01	15Bits Integration
			10	14Bits Integration
			11	13Bits Integration
Reserved	5:4	10	10	Reserved
ALS_GAIN	3:2	00	00	Gain 1X (default)
			01	Gain 4X
			10	Gain 16X

OPTICAL SENSOR LTR-2568ALS-01

			11	Gain 64X
ALS SAR_ENB*2	1	0	0	Enable (default)
			1	Disable
ALS MODE*1	0	0	0	Stand-by mode (default)
			1	Active mode

- *1 Prior to enabling ALS, 0xAD must be set to 0x18 and 0x7F must be set to 0x00. There are also certain programming steps to follow through in order to do dark offset via firmware. Please refer to **Enable ALS** pseudocode for complete instructions.
- *2 When ALS_SAR_ENB=0 and under Gain=1, the ALS DATA may not be complete. Firmware needs to read the SAR value and reconstruct the actual ALS DATA.

PS_CONTR Register (0x81) (Read/Write)

The PS_CONTR register controls the PS operation modes and software reset for sensor. The PS sensor can be set to either standby mode or active mode. At either of these modes, the I2C circuitry is always active. The default mode after power up is standby mode. During standby mode, there is no PS measurement performed but I2C communication is allowed to enable read/write to all the registers. **Register 0xA4 must be set to 0x04 and register 0xAD must be set to 0x18 before enabling PS. If PS SAR is used, 0xB7 must be set to 0x10 before enabling PS. For details of PS SAR, please refer to Figure 6.1 and Figure 7.4.1**

0x81	PS_CONTR (default = 0x10)							
	Bit 7	Bit 6	Bit 5	Bit 4	Bit 3	Bit 2	Bit 1	Bit 0
	Reserved		Resolution	Reserved	PS_OS	FTN/NTF enable	PS Mode	SW Reset

Field	Bits	Default	Description
Reserved	7:6	00	Must write as 10
Resolution	5	0	0 11 bit Display (default)
			1 16 bit Display
Reserved	4	1	Must write 1
PS_OS	3	0	PS Offset/Xtalk Cancellation. When enabled, PS DATA will be subtracted with PS OFFSET register (0x9F + 0x9E) data.
			0 Disabled (default)

OPTICAL SENSOR LTR-2568ALS-01

			1	Enabled
FTN/FTN EN	2	0	0	Disable FTN/NTF Status reporting (default)
			1	Enable FTN/NTF Status reporting
PSMODE ^{*1}	1	0	1	Active Mode
			0	Stand-by mode (default)
SW_RST	0	0	Reset registers to default values, with sensor into standby mode.	
			0	No action (default)
			1	Reset Registers to default values (including calibration values)

• ^{*1} Prior to enabling PS Mode, 0xA4 must be set to 0x04 and 0xAD must be set to 0x18. If PS SAR is used, 0xb7 must be set to 0x10.

Please refer to **Enable PS** pseudocode for complete instructions

PS_LED Register (0x82) (Read/Write)

The PS_LED register controls the LED pulse width and LED peak current. **The minimum drive current should be 5.5mA.**

0x82	PS_LED (default = 0x7A)							
	Bit 7	Bit 6	Bit 5	Bit 4	Bit 3	Bit 2	Bit 1	Bit 0
	Reserved			PLED Pulse Width		LED current		

Field	Bits	Default	Description	
Reserved	7:5	011	Must write as 011	
PLED Pulse Width	4:3	11	00	4us
			01	8us
			10	16us
			11	32us (default)
LED current	2:0	010	010	3.5 mA (default)
			011	4.5 mA
			100	5.5 mA
			101	6.5 mA
			110	7 mA

**OPTICAL SENSOR
LTR-2568ALS-01**

			111	9 mA
--	--	--	-----	------

PS_N_Pulses Register (0x83) (Read/Write)

The PS_N_Pulses register controls the PS averaging factor and LED pulses to be emitted.

0x83	PS_N_Pulses (default = 0x00)							
	Bit 7	Bit 6	Bit 5	Bit 4	Bit 3	Bit 2	Bit 1	Bit 0
	<i>PS averaging factor</i>			<i>PS number of LED pulses</i>				

Field	Bits	Default	Description	
PS averaging factor	7:6	00	00	No average (default)
			01	2n averaging
			10	4n averaging
			11	8n averaging
PS number of LED pulses	5:0	000000	Specifies PS LED number of pulses. If PS number of pulse set to 0, the pulse count will be 1.	

PS_MEAS_RATE Register (0x84) (Read/Write)

The PS_MEAS_RATE register controls the timing of the periodic measurements of the PS in active mode.

Measurement Repeat Rate is the interval between DATA registers update.

0x84	PS_MEAS_RATE (default = 0x04)							
	Bit 7	Bit 6	Bit 5	Bit 4	Bit 3	Bit 2	Bit 1	Bit 0
	<i>Reserved</i>					<i>PS Measurement Repeat Rate</i>		

Field	Bits	Default	Description
Reserved	7:3	00000	Must write as 00000

**OPTICAL SENSOR
LTR-2568ALS-01**

PS Measurement Rate	2:0	100	000	6.125ms
			001	12.5ms
			010	25ms
			011	50ms
			100	100ms (default)
			101	200ms
			110	400ms
			111	800ms

ALS_INT_TIME Register (0x85) (Read/Write)

The ALS_MEAS_RATE register controls the integration time and timing of the periodic measurement of the ALS in active mode.

0x85	ALS_INT_TIME (default = 0x06)							
	Bit 7	Bit 6	Bit 5	Bit 4	Bit 3	Bit 2	Bit 1	Bit 0
	Reserved				ALS Integration Time		ALS Measurement Rate	

Field	Bits	Default	Description	
Reserved	7:4	0000	Must write as 1010	
ALS Integration Time	3:2	01	00	50msec
			01	100msec (default)
			10	200msec
			11	400msec
ALS measurement rate	1:0	10	00	100msec
			01	200msec
			10	400msec (default)
			11	800msec

**OPTICAL SENSOR
LTR-2568ALS-01**

PART_ID Register (0x86) (Read Only)

The PART_ID register defines the part number and revision identification of the sensor.

0x86	PART_ID (default = 0x1C)							
	Bit 7	Bit 6	Bit 5	Bit 4	Bit 3	Bit 2	Bit 1	Bit 0
	Part Number ID				Revision ID			

MANUFAC_ID Register (0x87) (Read Only)

The MANUFAC_ID register defines the manufacturer identification of the sensor.

0x87	MANUFAC_ID (default = 0x05)							
	Bit 7	Bit 6	Bit 5	Bit 4	Bit 3	Bit 2	Bit 1	Bit 0
	Manufacturer ID							

ALS_STATUS Register (0x88) (Read Only)

The ALS_STATUS register stores information about ALS Gain, ALS SAR as well as ALS data status. New data means data has not been read before. Every time measurement is done and data is written to the data register, data status bit should be set to logic 1. Every time the data register is read, data status bit should be set to logic 0.

0x88	ALS_STATUS (default = 0x00)							
	Bit 7	Bit 6	Bit 5	Bit 4	Bit 3	Bit 2	Bit 1	Bit 0
	Reserved	Valid	ALS_Gain			ALS_SAR	Reserved	ALS Data Status

OPTICAL SENSOR LTR-2568ALS-01

Field	Bits	Default	Description	
Reserved	7	0	0	Must write as 0
ALS Data Valid	6	0	0	ALS Data is Valid (default)
			1	ALS Data is Invalid
ALS Data Gain Range	5:3	000	000	Gain 1X (default)
			001	Gain 4X
			010	Gain 16X
			011	Gain 64X
ALS SAR (DR) Extension	2	0	0	No Extension (SAR code = 0)
			1	With Extension (SAR code != 0)
Reserved	1	0	Reserved	
ALS data status	0	0	0	OLD data (data already read), (default)
			1	NEW data (first time data is read)

IR_DATA Register (0x89,0x8A) (Read Only)

The IR Channel measurement results are stored in the IR_DATA registers.

Field	Bits	Default	Description
IR_LSB	0x89	0000 0000	IR low byte data, bit 0 is LSB of the 16-bit data
IR_MSB	0x8A	0000 0000	IR high byte data, bit 7 is MSB of the 16-bit data

ALS_DATA Register (0x8B,0x8C) (Read Only)

ALS measurement results are stored in ALS_DATA registers.

Field	Bits	Default	Description
ALS_LSB	0x8B	0000 0000	ALS low byte data, bit 0 is LSB of the 16-bit data
ALS_MSB	0x8C	0000 0000	ALS high byte data, bit 7 is MSB of the 16-bit data

OPTICAL SENSOR LTR-2568ALS-01

PS_Status Register (0x91) (Read Only)

0x91	PS_Status (default = 0x08)							
	Bit 7	Bit 6	Bit 5	Bit 4	Bit 3	Bit 2	Bit 1	Bit 0
	Reserved		FTN	NTF	Reserved	PS IR Ambient Saturation	PS Interrupt Status	PS Data Status

Field	Bits	Default	Description	
Reserved	7:6	00		Reserved
FTN	5	0	0	No far to near object detected (default)
			1	Far to near object detected
NTF	4	0	0	No near to far object detected (default)
			1	Near to far object detected
Reserved	3	1		Reserved
PS IR Ambient Saturation	2	0	0	No PS IR ambient saturation (PS data is valid)
			1	PS IR Ambient saturation happens (PS data is invalid)
PS interrupt status	1	0	0	interrupt signal INACTIVE (default)
			1	interrupt signal ACTIVE
PS data status	0	0	0	OLD data (data already read), (default)
			1	NEW data (first time data is read)

PS_DATA Register (0x92 ~ 0x93) (Read Only)

PS measurement results are stored in PS_DATA registers. Bit 7 of PS_Data MSB is used to report SAR status when 11-bit resolution is used. For 16-bit resolution, Bit 7 is solely part of PS_Data_MSB. In the latter case, SAR status can be read from PS_STATUS Register 0x91<2>.

0x92	PS_Data LSB (default = 0x00)							
	Bit 7	Bit 6	Bit 5	Bit 4	Bit 3	Bit 2	Bit 1	Bit 0
	PS Data LSB							

**OPTICAL SENSOR
LTR-2568ALS-01**

Field	Bits	Default	Description
PS_Data LSB	7:0	0000 0000	PS measurement data LSB

0x93	PS_Data MSB (default = 0x00)							
	Bit 7	Bit 6	Bit 5	Bit 4	Bit 3	Bit 2	Bit 1	Bit 0
	<i>PS Data MSB</i>							

Field	Bits	Default	Description	
PS IR Ambient Saturation (valid for 11-bit only)	7	0	0	No PS IR ambient saturation (PS data is valid)
			1	PS IR Ambient saturation happens (PS data is invalid)
PS_Data MSB (valid for 16-bit only)	7	0		PS_Data MSB
PS_Data MSB	6:3	0000		PS_Data MSB

PS IR Ambient Register (0x94) (Read Only)

PS Coarse IR Ambient measured value is stored in this register.

Field	Bits	Default	Description
PS_IR_Ambient	0x94<3:0>	00000000	4 bits PS IR Ambient measured value

ALS Coarse Ambient Register (0x95) (Read Only)

PS Coarse Ambient measured value is stored in this register.

Field	Bits	Default	Description
ALS_Coarse_Ambient	0x95<3:0>	00000000	4 bits ALS Coarse Ambient measured value

OPTICAL SENSOR LTR-2568ALS-01

INTERRUPT Register (0x98) (Read/Write)

INTERRUPT register controls the operation of the interrupt pin and functions. The PS_STATUS register is updated even if interrupt pin is INACTIVE / high-impedance state. **Bit 7 of 0x98 must be set to 1 even though Interrupt function is not used.**

0x98	INTERRUPT (default = 0x08)							
	Bit 7	Bit 6	Bit 5	Bit 4	Bit 3	Bit 2	Bit 1	Bit 0
	Reserved					Interrupt Polarity	Interrupt Mode	

Field	Bits	Default	Description	
Reserved	7:3	00001		Must write as 10000
Interrupt Polarity	2	0	0	INT pin is considered active when it is a logic 0 (default)
			1	INT pin is considered active when it is a logic 1
Interrupt mode	1:0	00	00	Interrupt pin is INACTIVE / high impedance state (default)
			01	Only PS measurement can trigger interrupt
			1x	Reserved

INTERRUPT PERSIST Register (0x99) (Read/Write)

INTERRUPT PERSIST register sets the N number of times the measurement is out of the threshold range settings before asserting the INTERRUPT pin.

0x99	INTERRUPT PERSIST (default = 0x00)							
	Bit 7	Bit 6	Bit 5	Bit 4	Bit 3	Bit 2	Bit 1	Bit 0
	PS_PERSIST				Reserved			

Field	Bits	Default	Description	
PS_PERSIST	7:4	0	0	Every ALS value out of threshold range (default)
			1	1 consecutive PS values out of threshold range

**OPTICAL SENSOR
LTR-2568ALS-01**

		
			1111	15 consecutive PS values out of threshold range
Reserved	3:0	0		Reserved

PS_THRESHOLD Register (0x9A -0x9D) (Read/Write)

PS_THRESHOLD registers are used to set the upper and the lower limits of the absolute interrupt threshold value. Interrupt function compares the value in the PS_THRESHOLD registers to measured data value in PS_DATA registers. The data format for PS_THRESHOLD registers must be the same as that of PS_DATA registers. PS_Threshold registers must be written in the sequence of LSB first and then followed by MSB.

Field	Bits	Default	Description	
PTH_HIGH LSB	0x9A	11111111	--	PS upper interrupt threshold value, LSB
PTH_HIGH MSB	0x9B	11111111	--	PS upper interrupt threshold value, MSB
PTH_LOW LSB	0x9C	00000000	--	PS lower interrupt threshold value, LSB
PTH_LOW MSB	0x9D	00000000	--	PS lower interrupt threshold value, MSB

PS_OFFSET Register (0x9E -0x9F) (Read/Write)

PS OFFSET registers let user define PS crosstalk of the device. PS data will be subtracted by this OFFSET value if PS_OS is enabled at register 0x81.

Field	Bits	Default	Description
PS OFFSET LSB	0x9E	0	PS OFFSET LSB
PS OFFSET MSB	0x9F	0	PS OFFSET MSB

OPTICAL SENSOR LTR-2568ALS-01

LED_DRIVE Register(0xA4) (Read/Write)

LED DRIVE register controls the LED driving current capability. **Bit 2 must be set to 1 for VCSEL as module is integrated with VCSEL LED.**

0xA4	LED_DRIVE (default = 0x00)							
	Bit 7	Bit 6	Bit 5	Bit 4	Bit 3	Bit 2	Bit 1	Bit 0
	Reserved					Vcsel driver	Reserved	

Field	Bits	Default	Description
Reserved	7:3	00000	Must write as 00000
Vsel driver	2	0	Vsel Must write as 1
Reserved	1:0	00	Must write as 00

PS IR Ambient Saturation Threshold Register (0xB6) (Read/Write)

The proximity sensor has a function that measures the IR Ambient light and this value is compared to a threshold that is written into this register. If the value of the measured IR Ambient light is higher than the threshold, PS Data is then forced to 0 and IR Saturation flag is set.

0xB6	PS IR Ambient Saturation Threshold Register (default = 0x08)							
	Bit 7	Bit 6	Bit 5	Bit 4	Bit 3	Bit 2	Bit 1	Bit 0
	Reserved				IR Ambient Threshold Value			

Field	Bits	Default	Description
Reserved	7:4	0000	Must write as 0000
Threshold Value	3:0	1000	0000 – 0 0001 – 1 . 1110 - 14 1111 – 15

OPTICAL SENSOR LTR-2568ALS-01

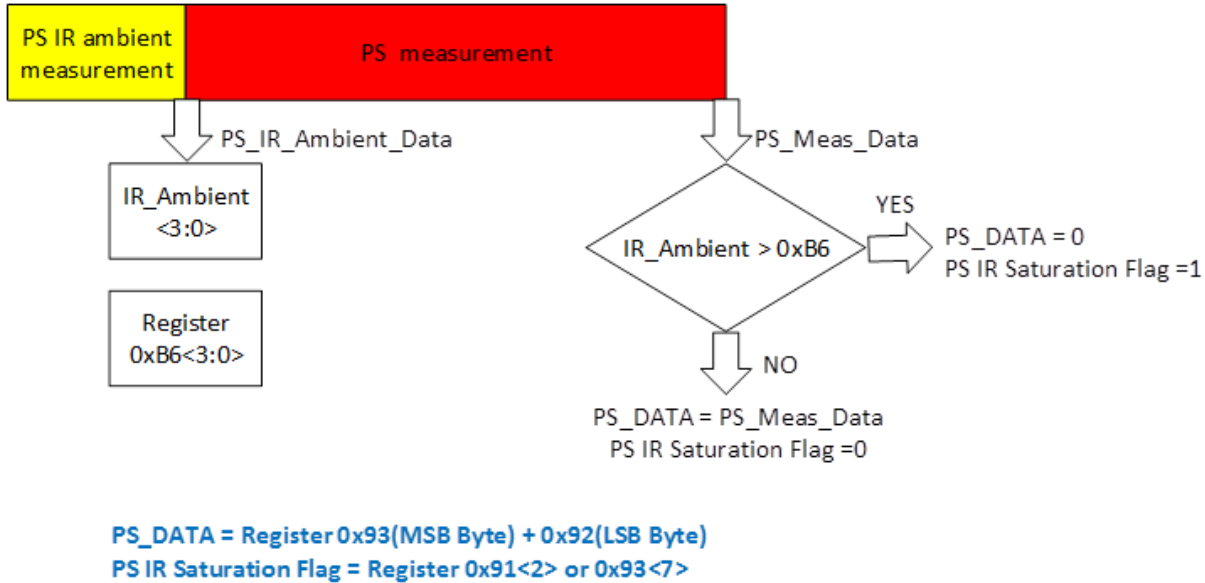

Figure 6.1

Figure 6.1 shows the Configurable PS IR Ambient saturation detection. Just before every PS measurement, an IR ambient measurement is done. The output is a 4-bit data (IR_Ambient 0x94<3:0>). The resolution of IR_Ambient is about 8K Lux/count of direct sunlight.

After PS measurement is done, the value of IR_Ambient 0x94<3:0> is compared to a writeable register 0xB6<3:0>. If IR_Ambient 0x94<3:0> value is greater than 0xB6<3:0> value, the PS_DATA reported is 0 and PS IR saturation flag is set to 1. Else, PS_DATA reported is the actual measured PS Data (PS_Meas_Data) and PS IR saturation flag is set to 0.

A proximity Sunlight Saturation status flag 0x91<2> will return a value of 1 if the above condition is met to validate the zero proximity count is due to saturation.

Alternatively, the proximity Sunlight Saturation status flag is also mirrored in 0x93<7> (only for 11-bit resolution). This register is part of the proximity data registers (0x93 + 0x92).

This method is used to ensure the proximity operation does not become unstable and cause a false detection due to interference caused by very high IR ambient (i.e. under strong sunlight).

The recommended value of 0xB6 = 0x06, which correspond to at least about 50Klux of direct sunlight before Sunlight Saturation is met.

OPTICAL SENSOR LTR-2568ALS-01

DSS CONTR Register (0xB7) (Read/Write) –PS SAR related

The DSS_CONTR register control the DSS features, it must be written with 0x10 before enabling PS. For details, please refer to diagram 7.3.3

0xB7	DSS CONTR Register (default = 0x10)							
	Bit 7	Bit 6	Bit 5	Bit 4	Bit 3	Bit 2	Bit 1	Bit 0
	<i>Reserved</i>							

Field	Bits	Default	Description
Reserved	7:0	0000 0000	Must write as 0001 0000

MAIN_CONFIG Register (0xAD) (Read/Write)

The MAIN_CONFIG register must be written with 0x18 before enabling ALS/PS

0xAD	MAIN_CONFIG Register (default = 0x00)							
	Bit 7	Bit 6	Bit 5	Bit 4	Bit 3	Bit 2	Bit 1	Bit 0
	<i>Reserved</i>							

Field	Bits	Default	Description
Reserved	7:0	0000 0000	Must write as 0001 1000

DARK CONFIG Register (0xB9) (Read)

The DARK_CONFIG register is a read-only register that stores the ALS Dark Count offset value. Firmware will need to offset the ALS count according to code in Bit <7:5>. Please refer to pseudocode under section Dark Offset.

0xB9	Dark CONFIG Register (default = 0x00)							
	Bit 7	Bit 6	Bit 5	Bit 4	Bit 3	Bit 2	Bit 1	Bit 0
	<i>ALS Dark Offset</i>			<i>Reserved</i>				

**OPTICAL SENSOR
LTR-2568ALS-01**

7. Application Information

7.1 ALS Lux Conversion formula

7.1.1 Lux formula for all Gains

Lux_Calc is the calculated lux reading based on the output ADC from ALS DATA regardless of light sources.

$$Lux_{Calc} = \frac{0.182 \times ALS_{DATA}}{(GAIN \times INT)} \times Window\ Factor$$

Where :

1. For device under tinted window with coated-ink of flat transmission rate at 400-600nm wavelength, window factor is to compensate light loss due to the lower transmission rate from the coated-ink.
 - a. WFAC = 1 for NO window / clear window glass.
 - b. WFAC >1 device under tinted window glass. Calibrate under white LED.

2. The Gain factors & Integration time factors:

ALS Gain	GAIN
X1	1
X4	4
X16	16
X64	64

Integration Time (ms)	INT
50	0.5
100	1
200	2
400	4

OPTICAL SENSOR LTR-2568ALS-01

7.1.2 Lux formula Gainx1 SAR extension

LTR-2568ALS-01 has dynamic extension feature available only for Gainx1 by using conversion formula using SAR value read from register <0x95>.

$$Data = ALS_{Data} + \frac{2^{15} * (SAR_CODE - 1)}{IntFac}$$

SAR_CODE = 0x95<3:0>

7.2 Operating Mode

Stand-by Mode

The device is by default in stand-by mode after power-up. No measurement activity done in either ALS or PS. I2C communication is allowed to be able to read/write to the registers. The device can be reset from MCU by setting appropriate register control (SW reset). Start-up sequence is exactly the same as that when power-on reset is triggered.

Active Mode

The ALS and PS can simultaneously be in active mode (see Fig 1). Measurement data is expected to be available within a known fixed time (refer to measurement time parameter from ALS and PS specification).

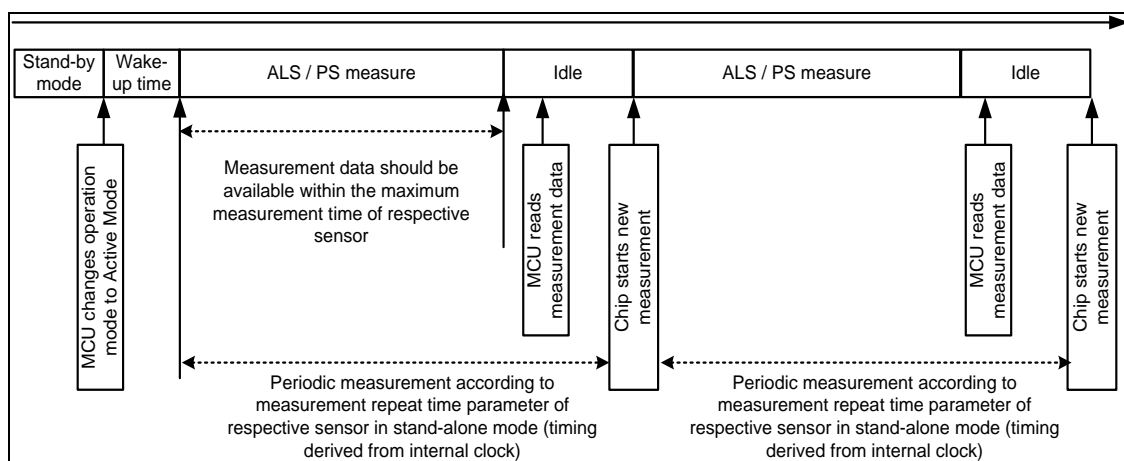

Figure 7.2.1 : ALS and PS measurement sequence

OPTICAL SENSOR LTR-2568ALS-01

7.3 Interrupt Features

The interrupt function is active if PS measurements are outside of the upper and lower absolute threshold levels set in the appropriate threshold register. Only newly measured data is compared to the threshold levels set such that old data will not cause triggering of the INT pin if in case the threshold levels are changed in between measurements.

The status of interrupt can be monitored directly through the interrupt (INT) pin or by checking contents of the interrupt register. Interrupt pin can either be enable or disabled. It is possible to invert interrupt output of LOW or HIGH state.

Interrupt pin IO requirements are exactly the same as those of the I2C bus pins SDA and SCL.

There are two user selectable types of interrupt, namely window interrupt type & logic interrupt type. Refer to Figure7.3.1 and 7.3.2 for illustration.

OPTICAL SENSOR LTR-2568ALS-01

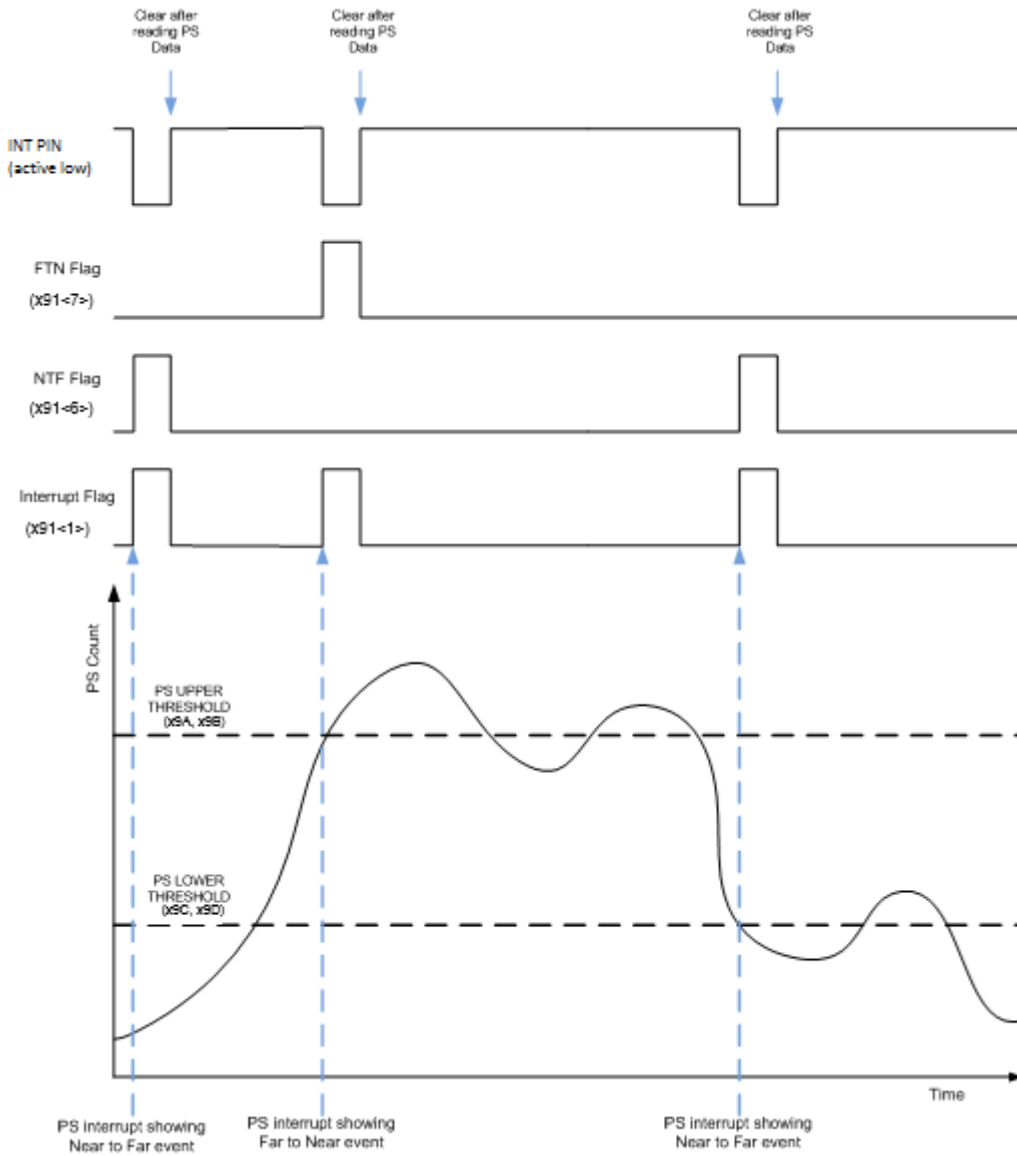

Figure 7.3.1 : Interrupt illustration on logic type (with NTF/FTN reporting)

(Logic Mode: activated by control register PS_CONTR (0x81<2>) and INTERRUPT (0x91<1>))

**OPTICAL SENSOR
LTR-2568ALS-01**

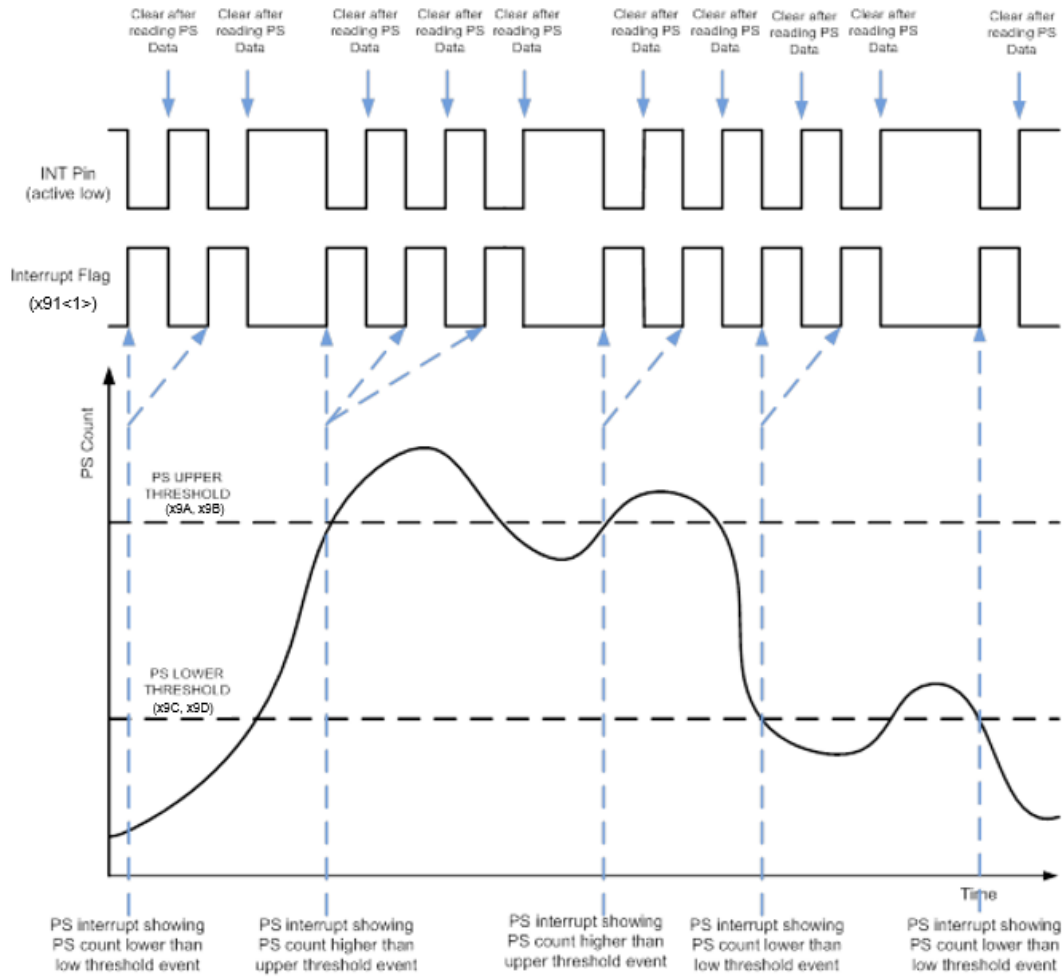

Figure 7.3.2 : Interrupt illustration on window type (by default, without NTF/FTN reporting)

OPTICAL SENSOR LTR-2568ALS-01

7.4 PS Dynamic Sunlight Saturation (DSS) Detection

The proximity sensor ADC circuit is configured as a coarse “ambient light sensor” briefly before each actual proximity measurement to determine the IR ambient light level. The resolution is about 8KLux/count of direct sunlight. The measured coarse ADC value is reflected in register 0x94<3:0> (PS IR Ambient).

Register 0xB6<3:0> (PS IR Ambient Saturation Threshold) is used to set the threshold to trigger a Sunlight Saturation condition. If the value of PS IR Ambient register is above the PS IR Ambient Saturation Threshold register, the proximity ADC measurement data reported is masked to zero.

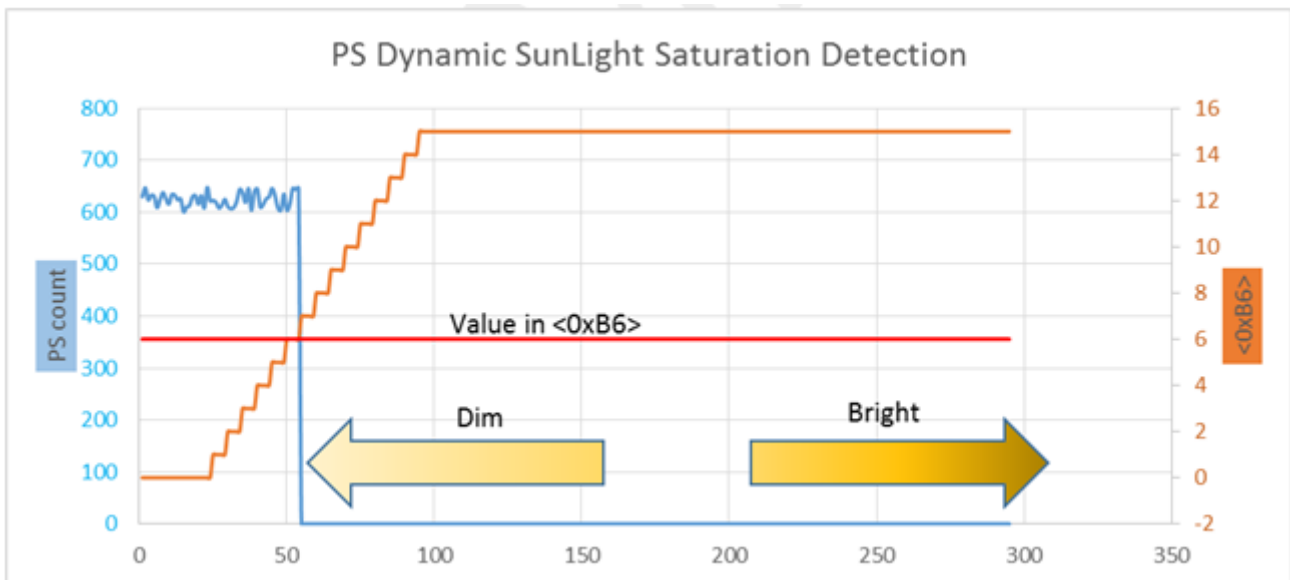
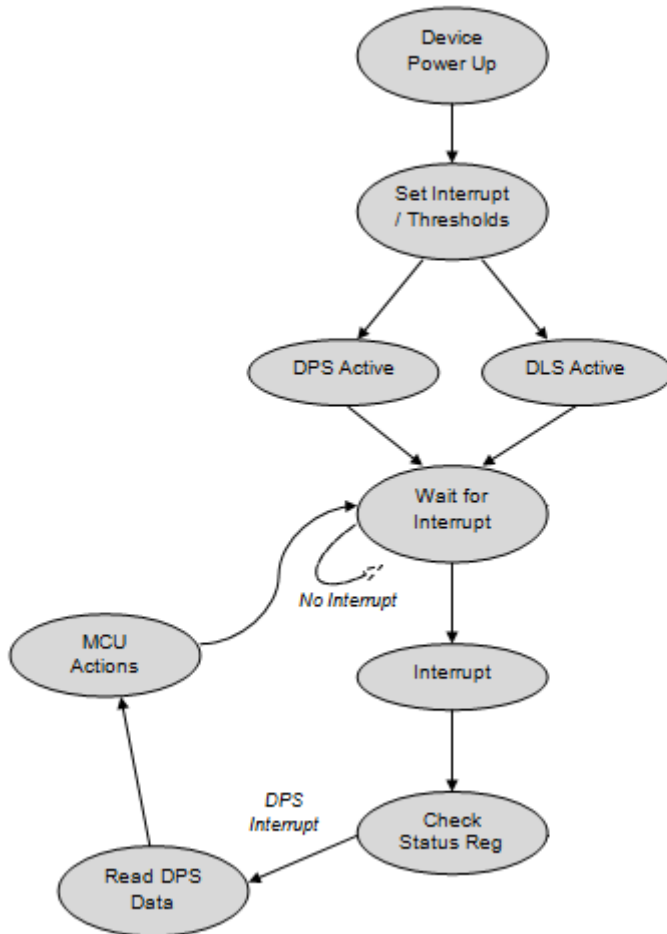

Figure 7.4.1 : DSS feature illustration under sunlight

**OPTICAL SENSOR
LTR-2568ALS-01**

Flow diagram below illustrates the operation flow, and involving the use of Thresholds and interrupt.



OPTICAL SENSOR LTR-2568ALS-01

8. Pseudo Codes Examples

LED Driver Registers

// This LED DRIVE registers define the VCSEL current control

// The register must be set to 0x04 to appropriate VCSEL driving current is used.

```
Slave_Addr = 0x23 // Slave address of LTR-2568ALS-01 device
Register_Addr = 0xA4
Command = 0x04 // For selecting VCSEL driving current ,Command = 0x04
```

PS LED Registers

// The PS LED Registers define the driving peak current.

```
Slave_Addr = 0x23 // Slave address of LTR-2568ALS-01 device
```

// Set LED Pulse width 4us (with default peak current of 3.5mA)

// Default setting is 0x7A (Pulse width 32us, 3.5mA).

```
Register_Addr = 0x82 // PS_LED register
Command = 0x62 // For Pulse width=4us,Command = 0x62
// For Pulse width = 8us, Command = 0x6A
// For Pulse width = 16us, Command = 0x72
// For Pulse width = 32us, Command = 0x7A
```

```
WriteByte(Slave_Addr, Register_Addr, Command)
```

// Set LED Peak Current 5.5mA (with default pulse width 32us)

```
Register_Addr = 0x82 // PS_LED register
Command = 0x7A // For Peak Current = 5.5mA, Command = 0x7C
// For Peak Current = 6.5mA, Command = 0x7D
// For Peak Current = 7mA, Command = 0x7E
// For Peak Current = 9mA, Command = 0x7F
```

```
WriteByte(Slave_Addr, Register_Addr, Command)
```

PS_N_Pulses Register

// The PS_N_Pulses register controls the number of LED pulses to be emitted.

// Default setting is 0x00.

```
Slave_Addr = 0x23 // Slave address of LTR-2568ALS-01 device
```

// Set PS averaging factor 0 (with default number of pulse 1)

```
Register_Addr = 0x83 // PS_N_Pulses register
Command = 0x00 // For PS averaging factor 0, Command = 0x00,
// For PS averaging factor 2, Command = 0x40,
// For PS averaging factor 4, Command = 0x80,
// For PS averaging factor 8, Command = 0xC0,
```

OPTICAL SENSOR LTR-2568ALS-01

// Set LED Pulses to 2 Pulses (with default PS averaging factor 0)

```
Register_Addr = 0x83 // PS_N_Pulses register
Command = 0x01 // For PS pulses = 2,
// For PS pulses = 3, Command = 0x02
// For PS pulses = 4, Command = 0x03
// .....
// For PS pulses = 16, Command = 0x0F
// For PS pulses = 64, Command = 0x3F
```

WriteByte(Slave_Addr, Register_Addr, Command)

PS Measurement Rate

// PS_MEAS_RATE register controls the PS measurement rate which define the interval between DATA update.
// Default setting of the register is 0x04

Slave_Addr = 0x23 // Slave address of LTR-2568ALS-01 device

// Set PS Repeat Rate 6.125ms

```
Register_Addr = 0x84 // PS_MEAS_RATE register
Command = 0x00 // Meas rate = 6.125ms
// For Meas rate = 12.5ms, Command = 0x01
// For Meas rate = 25ms, Command = 0x02
// For Meas rate = 50ms, Command = 0x03
// For Meas rate = 100ms, Command = 0x04
// For Meas rate = 200ms, Command = 0x05
// For Meas rate = 400ms, Command = 0x06
// For Meas rate = 800ms, Command = 0x07
```

WriteByte(Slave_Addr, Register_Addr, Command)

ALS Integration Time

// The ALS_INT_TIME register controls the ALS integration time and ALS measurement rate.
// Default setting of the register is 0x06

Slave_Addr = 0x23 // Slave address of LTR-2568ALS-01 device

// Set ALS integration time 50msec (with default ALS measurement rate 400ms)

```
Register_Addr = 0x85 // ALS_INT_TIME register
Command = 0xA2 // Integration time = 50msec
// For Integration time = 100msec, Command = 0xA6
// For Integration time = 200msec, Command = 0xAA
// For Integration time = 400msec, Command = 0xAE
```

// Set ALS measurement rate 100msec (with default ALS integration time 100ms)

```
Register_Addr = 0x85 // ALS_INT_TIME register
Command = 0xA4 // measurement rate = 100msec
// measurement rate = 200msec, Command = 0xA5
// measurement rate = 400msec, Command = 0xA6
// measurement rate = 800msec, Command = 0xA7
```

WriteByte(Slave_Addr, Register_Addr, Command)

Interrupt Register

// The Interrupt register controls the operation of the interrupt pins and function.

OPTICAL SENSOR LTR-2568ALS-01

// The default value for this register is 0x08
// The bit7 must be 1.

Slave_Addr = 0x23 // Slave address of LTR-2568ALS-01 device

// Set INT pin is considered active when it is a logic 1 (with Interrupt pin is INACTIVE / high impedance state)

Register_Addr = 0x98 // INT pin is considered active when it is a logic 1
Command = 0x8C // INT pin is considered active when it is a logic 1=Command 0x8C
// INT pin is considered active when it is a logic 0=Command 0x88

// Set Only PS measurement can trigger interrupt (with INT pin is considered active when it is a logic 0)

Register_Addr = 0x98 // Only PS measurement can trigger interrupt
Command = 0x89 // Only PS measurement can trigger interrupt =Command 0x89
// Interrupt pin is INACTIVE / high impedance state =Command 0x88

WriteByte(Slave_Addr, Register_Addr, Command)

Interrupt Persist Register

// The Interrupt persist register controls the N number of times the measurement is out of the threshold range settings before asserting the INTERRUPT pin
// The default value for this register is 0x00

Slave_Addr = 0x23 // Slave address of LTR-2568ALS-01 device

// Set 1 consecutive PS values out of threshold range

Register_Addr = 0x99 // 1 consecutive PS values out of threshold range
Command = 0x10 // Every PS value out of threshold range =Command 0x00
// 1 consecutive PS values out of threshold range =Command 0x10
// 2 consecutive PS values out of threshold range =Command 0x20
//
// 15 consecutive PS values out of threshold range =Command 0xF0

// Set 1 consecutive ALS values out of threshold range (with Every PS value out of threshold range)

Register_Addr = 0x99 // 1 consecutive ALS values out of threshold range
Command = 0x01 // Every ALS value out of threshold range =Command 0x00
// 1 consecutive ALS values out of threshold range =Command 0x01
// 2 consecutive ALS values out of threshold range =Command 0x02
//
// 15 consecutive ALS values out of threshold range =Command 0x0F

WriteByte(Slave_Addr, Register_Addr, Command)

PS Threshold Registers

// The PS_THRES_UP and PS_THRES_LOW registers determine the upper and lower limit of the interrupt threshold value.
// Following example illustrates the setting of the PS threshold window of decimal values of 200 (lower threshold) and // 1000 (upper threshold).

Slave_Addr = 0x23 // Slave address of LTR-2568ALS-01 device

OPTICAL SENSOR LTR-2568ALS-01

// Upper Threshold Setting (decimal 1000)

```
PS_THRES_UP_0 = 0x9A // PS Upper Threshold Low Byte Register address
PS_THRES_UP_1 = 0x9B // PS Upper Threshold High Byte Register address
Data1 = 1000 >> 8 // To convert decimal 1000 into two eight bytes register values
Data0 = 1000 & 0xFF
```

```
WriteByte(Slave_Addr, PS_Upp_Threshold_Reg_0, Data0)
WriteByte(Slave_Addr, PS_Upp_Threshold_Reg_1, Data1)
```

// Lower Threshold Setting (decimal 200)

```
PS_THRES_LOW_0 = 0x9C // PS Lower Threshold Low Byte Register address
PS_THRES_LOW_1 = 0x9D // PS Lower Threshold High Byte Register address
Data1 = 200 >> 8 // To convert decimal 200 into two eight bytes register values
Data0 = 200 & 0xFF
```

```
WriteByte(Slave_Addr, PS_Low_Threshold_Reg_0, Data0)
WriteByte(Slave_Addr, PS_Low_Threshold_Reg_1, Data1)
```

PS OFFSET Registers

// PS OFFSET registers let user define PS crosstalk of the device. All PS data will be subtracted by this OFFSET registers.
// Following example illustrates the setting of the PS OFFSET of decimal values of 200

```
Slave_Addr = 0x23 // Slave address of LTR-2568ALS-01 device
```

// PS OFFSET Setting (decimal 200)

```
PS_OFFSET_0 = 0x9E // PS_OFFSET Low Byte Register address
PS_OFFSET_1 = 0x9F // PS_OFFSET High Byte Register address
Data1 = 200 >> 8 // To convert decimal 200 into two eight bytes register values
Data0 = 200 & 0xFF
```

```
WriteByte(Slave_Addr, PS_OFFSET_0, Data0)
WriteByte(Slave_Addr, PS_OFFSET_1, Data1)
```

Control Registers

// The Control Registers define the operating modes and gain settings of the ALS and PS of LTR-2568ALS-01.
// Main Control Register (0xAD) must be set to 0x18 before turning on ALS / PS function.
// It is recommended that Control Register for ALS (0x80) and PS (0x81) to be set at the end of the sequence.
// This is to ensure all register settings are the same for all started measurement.
// Default settings are 0x20 for ALS register and 0x10 for PS register (both in Standby mode after power up).

```
Slave_Addr = 0x23 // Slave address of LTR-2568ALS-01 device
```

// Enable ALS

```
Register_Addr = 0x7F // ALS_CONFIG register
Command = 0x00 // Enable
```

```
Register_Addr = 0xAD // MAIN_CONTR register
Command = 0x18 // Enable
```

```
Register_Addr = 0x80 // ALS_CONTR register
Command = 0x21 // For Dynamic Range x1
```

OPTICAL SENSOR LTR-2568ALS-01

// For Dynamic Range x4 , Command = 0x25
 // For Dynamic Range x16 , Command = 0x29
 // For Dynamic Range x64 , Command = 0x2D

WriteByte(Slave_Addr, Register_Addr, Command)

//Dark Offset

//Dark count control is available via firmware to control fine offset of dark count.
 //To offset the dark count, upon power up, select and enable dark control register 0xB4.
 //Then, device dark count reference will available in Register_Addr 0xB9<7:5>.
 //Based on the value in 0xB9<7:5>, dark offset value needs to be deducted from ALS Count via firmware using the value in table below.

0xB9<7:5>	Dark Offset value
000	0
001	20
010	40
011	60
100	80
101	100
110	120
111	140

//Setting procedures below realizing the explanation

Register_Addr = 0xB4 // Dark Control register
 Command = 0x1C // For selecting Dark Offset register
 Command = 0x1D // To confirm Dark Offset register selection

Register_Addr = 0xB9 // ALS Dark Offset address
 ReadByte(Slave_Addr, Register_Addr, Data0)
 Data0 = (Data0 >> 5) & 7 //Obtain dark offset references in 0xB9<7:5>

Register_Addr = 0x81 // For IC Reset
 Command = 0x01

// Enable PS

Register_Addr = 0xAD // MAIN_CONTR register
 Command = 0x18 // Enable
// LED driver register 0xA4 must be set to 0x04 prior any PS LED setting.
 Register_Addr = 0xA4 // LED_DRIVE
 Command = 0x04 // Set to Vsel
// Register 0xB7 must be enabled if PS SAR is required.
 Register_Addr = 0xB7 // DSS_CONTR
 Command = 0x10 // Enable

OPTICAL SENSOR LTR-2568ALS-01

```
Register_Addr = 0x81 // PS_CONTR register
Command = 0x92 // For PS 11 bits active
Command = 0xB2 // For PS 16 bits active
```

// Enable PS REGISTER OFFSET (with default PS 11 bit)

```
Register_Addr = 0x81 // PS_CONTR register
Command = 0x1A // For PS active & enable PS REGISTER OFFSET
```

// Enable FTN/NTF (with default PS 11 bit)

```
Register_Addr = 0x81 // PS_CONTR register
Command = 0x1E // For PS active & enable FTN/NTF
```

```
WriteByte(Slave_Addr, Register_Addr, Command)
```

Data Registers (Read Only)

```
// The ALS and PS Data Registers contain the ADC output data.
// These registers should be read as a group, with the lower address being read first.
```

```
Slave_Addr = 0x23 // Slave address of LTR-2568ALS-01 device
```

// Read ALS_DATA

```
Register_Addr = 0x8B // ALS ADC low byte address
ReadByte(Slave_Addr, Register_Addr, Data0)
Register_Addr = 0x8C // ALS ADC high byte address
ReadByte(Slave_Addr, Register_Addr, Data1)
```

```
ALS_ADC_Data = (Data1 << 8) | Data0 // Combining lower and upper bytes to give 16-bit ALS ADC data
(Direct conversion to illuminance in lux).
```

```
Slave_Addr = 0x23 // Slave address of LTR-2568ALS-01 device
```

// Read PS_DATA

```
Register_Addr = 0x92 // PS_DATA low byte address (7:0)
ReadByte(Slave_Addr, Register_Addr, Data0)
Register_Addr = 0x93 // PS_DATA high byte address (2:0)
ReadByte(Slave_Addr, Register_Addr, Data1)
```

```
PS_ADC_Data = ((Data1 << 8) | Data0) // Combining lower and upper bytes to give 16-bit PS data
```

ALS Status Register (Read Only)

```
// The ALS_STATUS Register contains the information on Interrupt, ALS data gain, validity and status.
```

```
Slave_Addr = 0x23 // Slave address of LTR-2568ALS-01 device
```

```
Register_Addr = 0x88 // ALS_STATUS register address
ReadByte(Slave_Addr, Register_Addr, Data)
```

```
ALS valid = Data & 0x40 // ALS data valid = 0x80 → ALS data is invalid
// ALS data valid = 0x00 → ALS data is valid
```

```
ALS Gain Range= Data & 0x38 // Gain Range = 0x00 → Gain x1
// Gain Range = 0x08 → Gain x4
```

OPTICAL SENSOR LTR-2568ALS-01

// Gain Range = 0x10 → Gain x16
// Gain Range = 0x18 → Gain x64

ALS Data_Status = Data & 0x01

// NewData_Status = 0x00 → OLD data
// NewData_Status = 0x01 → NEW data

PS Status Register (Read Only)

// The PS_STATUS Register contains the information on Interrupt, NTF/FTN information, ambient saturation and PS status.

Slave_Addr = 0x23

// Slave address of LTR-2568ALS-01 device

Register_Addr = 0x91

// PS_STATUS register address

ReadByte(Slave_Addr, Register_Addr, Data)

FTN = Data & 0x20

// FTN = 0x20 → FTN detected
// FTN = 0x00 → No FTN detected
// NTF = 0x10 → NTF detected
// NTF = 0x00 → No NTF detected

NTF = Data & 0x10

Ambient Saturation = Data & 0x04

// Ambient Saturation = 0x04 → Ambient Saturation happens
// Ambient Saturation = 0x00 → No ambient Saturation

PS_Interrupt_Status = Data & 0x02

// Interrupt_Status = 0x02 → PS interrupt is triggered
// Interrupt_Status = 0x00 → PS interrupt is not triggered

PS Data_Status = Data & 0x01

// NewData_Status = 0x00 → OLD data
// NewData_Status = 0x01 → NEW data

OPTICAL SENSOR LTR-2568ALS-01

9. Recommended Leadfree Reflow Profile

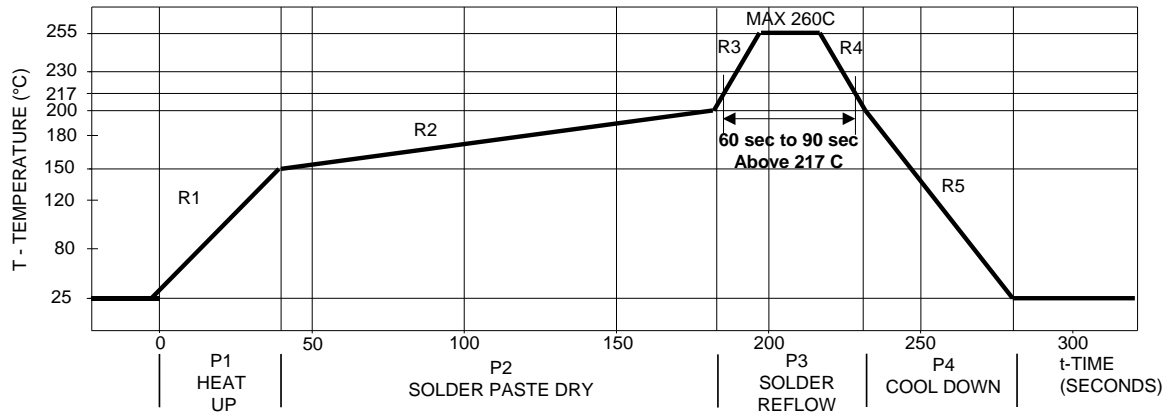

Process Zone	Symbol	ΔT	Maximum $\Delta T/\Delta$ time or Duration
Heat Up	P1, R1	25°C to 150°C	3°C/s
Solder Paste Dry	P2, R2	150°C to 200°C	100s to 180s
Solder Reflow	P3, R3	200°C to 260°C	3°C/s
	P3, R4	260°C to 200°C	-6°C/s
Cool Down	P4, R5	200°C to 25°C	-6°C/s
Time maintained above liquidus point , 217°C		> 217°C	60s to 90s
Peak Temperature		260°C	-
Time within 5°C of actual Peak Temperature		> 255°C	20s
Time 25°C to Peak Temperature		25°C to 260°C	8mins

It is recommended to perform reflow soldering no more than twice.

OPTICAL SENSOR LTR-2568ALS-01

10. Moisture Proof Packaging

All LTR-2568ALS-01 are shipped in moisture proof package. Once opened, moisture absorption begins. This part is compliant to JEDEC J-STD-033A Level 3.

10.1 Shelf Life

Device has the shelf life of 12 months if stored in an unopened moisture proof package. It is recommended to store in following condition.

- Shelf Life : 12 months
- Ambient Temperature : <40°C
- Relative Humidity: <90%

10.2 Floor Life

After removal from the moisture barrier bag, the parts should be stored at the recommended storage conditions and soldered within seven days.

- Floor Life : 168 hours
- Ambient Temperature : <30°C
- Relative Humidity: <60%

10.3 Rebaking information

When the moisture barrier bag is opened and the parts are exposed to the recommended storage conditions for more than seven days, the parts must be baked before reflow to prevent damage to the parts.

Baking Conditions

Package	Temperature	Time
In Reels	60°C	48 hours
In Bulk	100°C	4 hours

Baking should only be done once.

**OPTICAL SENSOR
LTR-2568ALS-01**

11. Recommended Land Pattern and Metal Stencil Aperture

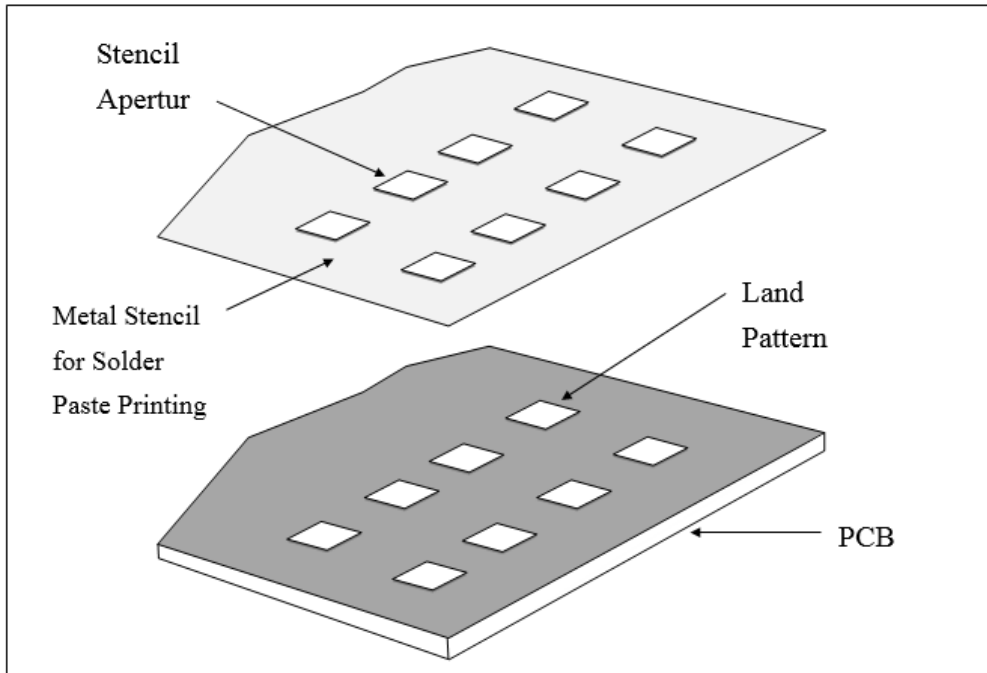

Recommended Land Pattern

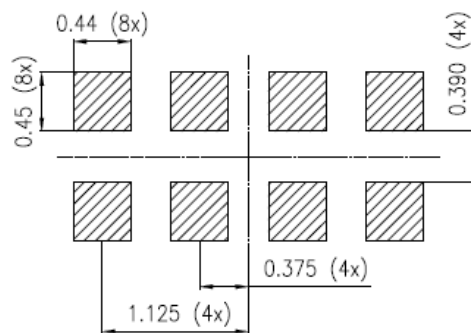

Note: All dimensions are in millimeters

**OPTICAL SENSOR
LTR-2568ALS-01**

12.Package Dimension for Tape and Reel

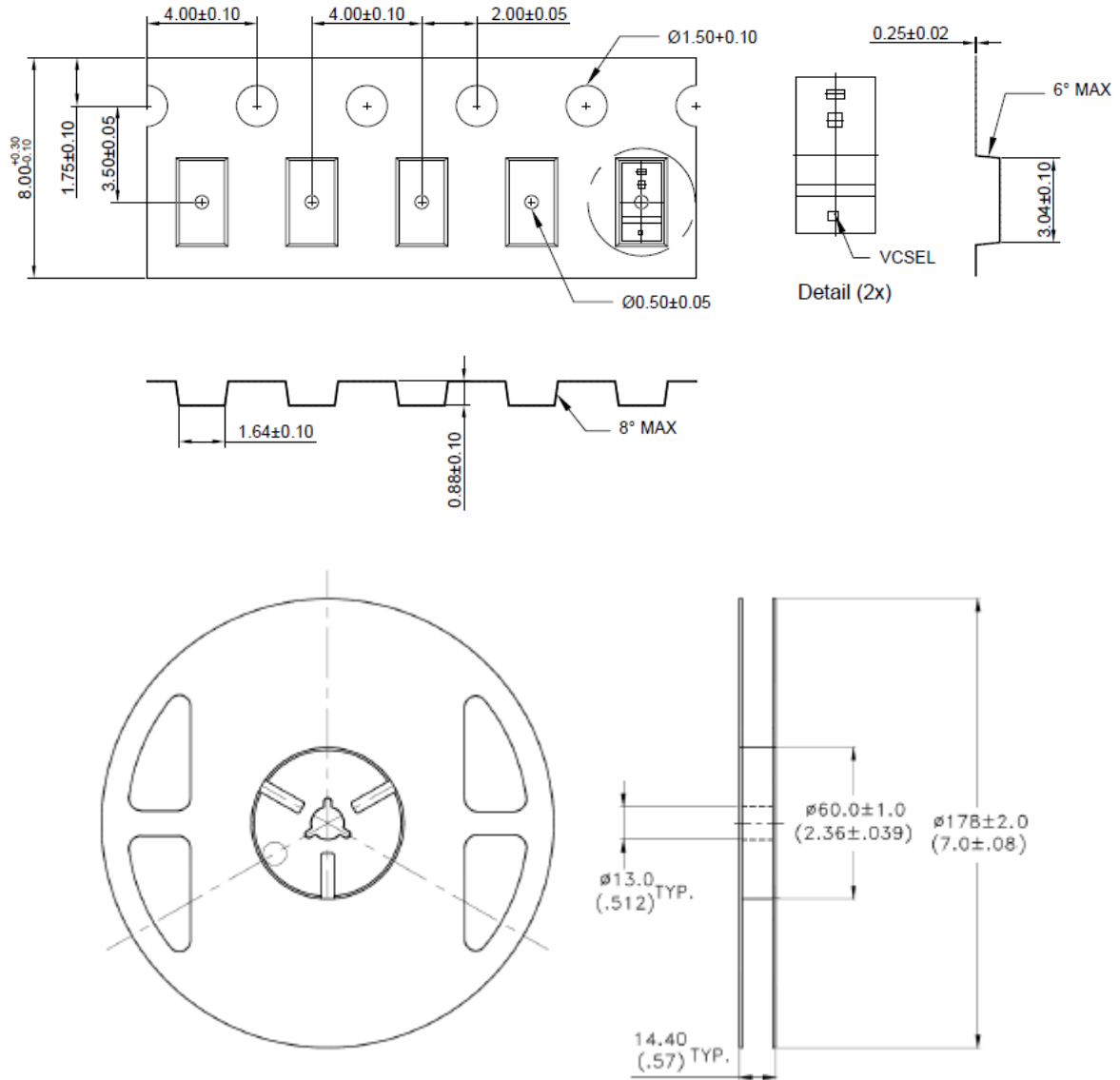

Notes:

1. All dimensions are in millimeters
2. Empty component pockets sealed with top cover tape
3. 7 inch reel - 4000 pieces per reel
4. In accordance with ANSI/EIA 481-1-A-1994 specifications

Part No. : LTR-2568ALS-01
BNS-

**OPTICAL SENSOR
LTR-2568ALS-01**

Revision Table:

Version	Update	Page	Date
1.0	Datasheet created	Total 46 pages	16/10/18
1.1	Added information for enabling PS and ALS	Page 14, 15, 16	17/10/18
1.2	Added related requirements from customer RFI	Page 5, 6, 7	21/10/18
1.3	Update on actual PS count min, max and typical & Vcsel viewing angle and sensitivity of ALS Add tolerance of the PS PD, VCSEL and ALS PD tolerance	Page 5, 6, 7	23/10/18
1.4	Update description to Pdata3-CT & Pdata5-CT	Page 7	30/10/18
1.5	Update the reel size 7 inches from 13 inches and reel qty to 4000	Page 1 , 47	21/12/18

单击下面可查看定价，库存，交付和生命周期等信息

[>>Lite-On\(光宝\)](#)