

Optical Sensor
Product Data Sheet
LTR-X1303-039

Spec No. :DS86-2022-0009
Effective Date: 05/28/2022
Revision: -

LITE-ON DCC

RELEASE

BNS-OD-FC001/A4

1. Description

The LTR-X1303-039 is an integrated low voltage I2C ambient light sensor (ALS), and proximity sensor (PS), with built-in emitter in a single miniature chip lead-free surface mount package.

The ALS provides a linear response over a wide dynamic range, which is well suited to applications under very low or bright ambient brightness. Besides, with built-in proximity sensor, this sensor offers the feature to detect object at a user configurable distance.

The sensor has a programmable interrupt with hysteresis to response to events and that removes the need to poll the sensor for a reading which improves system efficiency. This CMOS design and factory-set one time trimming capability ensure minimal sensor-to-sensor variations for ease of manufacturability to the end customers.

2. Features

- I²C interface (Standard mode @100kHz or Fast mode @400kHz)
- Ambient Light and Proximity Sensing in one ultra-small ChipLED package
- Very low power consumption with sleep mode capability
- Operating voltage ranges: 1.7V to 3.6V
- Operating temperature ranges: -40 to +85 °C
- Built-in temperature compensation circuit
- Programmable interrupt function for ALS and PS with upper and lower thresholds
- RoHS and Halogen free compliant

ALS Features

- 16 to 20 bits effective resolution
- Wide dynamic range with linear response
- Close to human eye spectral response
- Automatic rejection for 50Hz/60Hz lighting flicker

PS Features

- Built-in LED driver and detector
- High ambient light suppression
- 8 , 9, 10, 11-bit(selectable) effective resolution
- Cancellation of crosstalk
- Programmable LED drive settings

3. Applications

- Control brightness of display panel

Optical Sensor LTR-X1303-039

- Object detection in mobile, computing, and consumer devices.

4. Ordering Information

Part Number	Packaging Type	Package	Quantity
LTR-X1303-039	Tape and Reel	8-pin chipped package	1500

5. Outline Dimensions

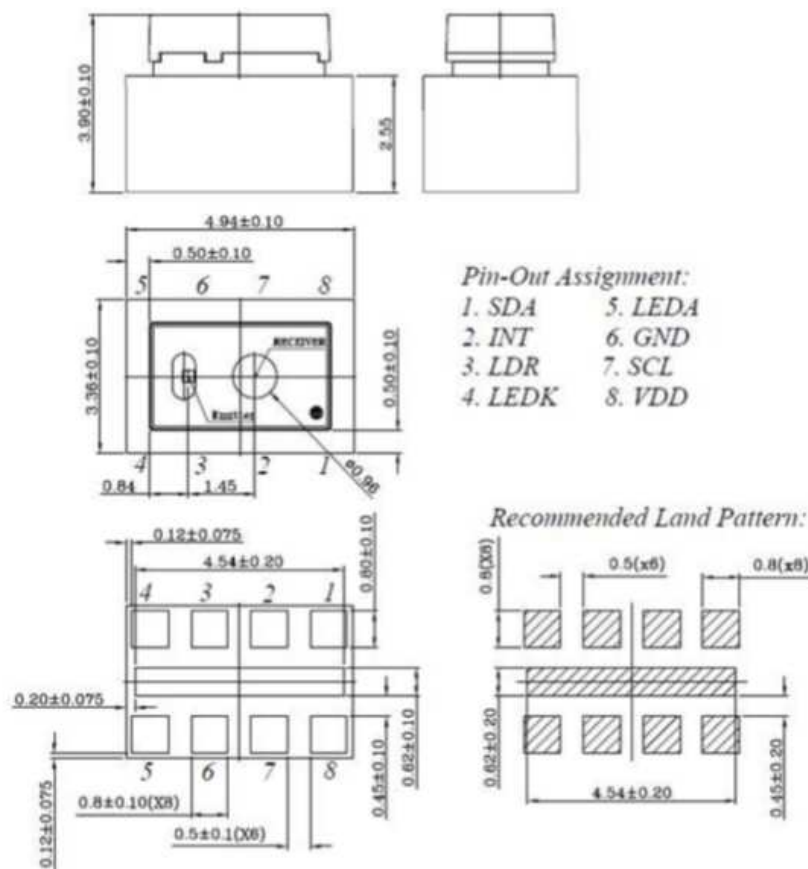

- Note: 1. All dimension in millimeter.
2. All dimension tolerance is 0.2mm unless specified.

6. Functional Block Diagram

LTR-X1303-039 contains 2 photodiodes (Visible and IR diode) for respective photocurrent measurement. The photodiode currents are converted to digital values by ADCs. The sensor also included an emitter LED, as well as some peripheral circuits such as an internal oscillator, a current source, voltage reference, and internal fuses to store trimming information.

**Optical Sensor
LTR-X1303-039**

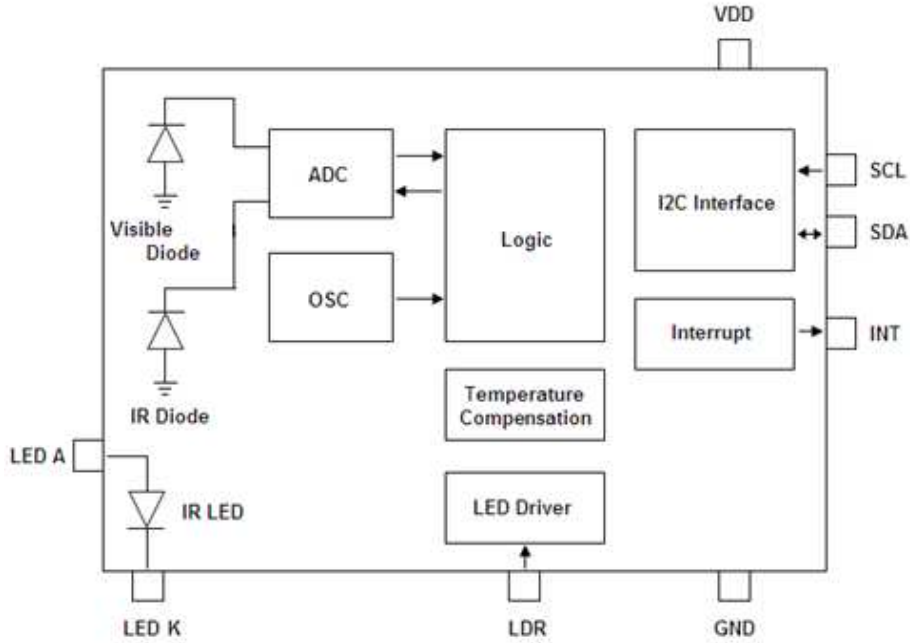

7. Application Circuit

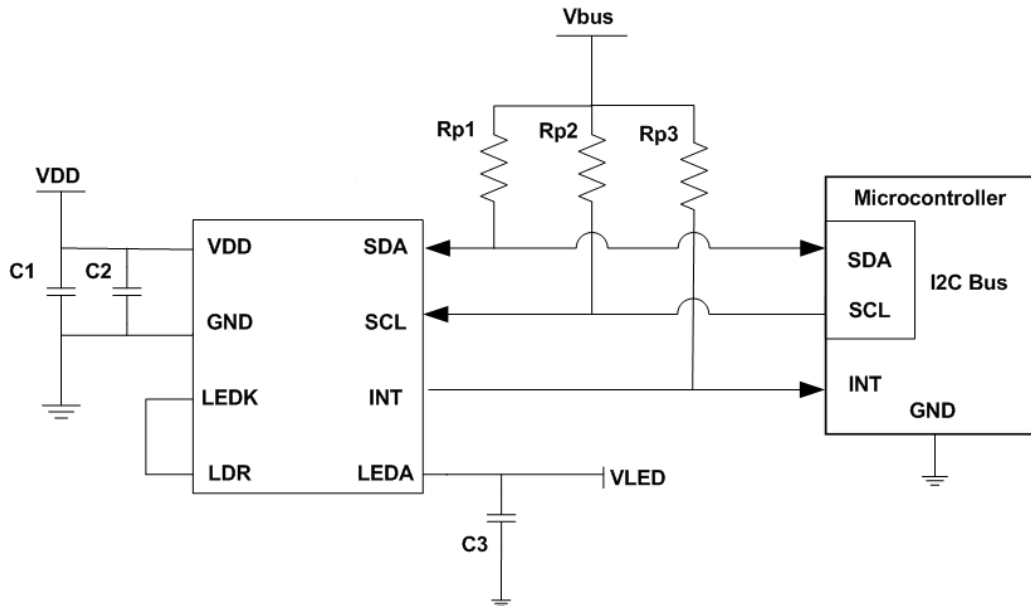

Note: It is a must that VDD and VLED to be separated.

I/O Pins Configuration Table

Pin	I/O Type	Symbol	Description
1	IN/OUT	SDA	I ² C serial data
2	OUT	INT	Interrupt
3	OUT	LDR	Connect to LED Cathode
4	OUT	LEDK	LED Cathode. Connect to LDR pin if internal LED driver circuit is used
5	IN	LEDA	LED Anode.
6	Ground	GND	Ground
7	IN	SCL	I ² C serial clock
8	Supply	VDD	Power Supply Voltage

Recommended Application Circuit Components

Component	Recommended Value
Rp1, Rp2, Rp3 [1]	1 kΩ to 10 kΩ
C1, C3	1uF ±20%, X7R / X5R Ceramic
C2	0.1uF

[1] Selection of pull-up resistors value is dependent on bus capacitance values. For more details, please refer to I²C Specifications: http://www.nxp.com/documents/user_manual/UM10204.pdf

8. Ratings and Specifications

Absolute Maximum Ratings at Ta = 25°C

Parameter	Symbol	Min.	Max	Unit
Supply Voltage	VDD		4.0	V
Digital Voltage Range	SCL, SDA, INT	-0.5	4.0	V
Max Voltage Range	LDR	-0.5	4.0	V
Storage Temperature	T _{stg}	-40	100	°C
Electrostatic Discharge Protection (Human Body Model JESD22-A114)	V _{HBM}		2000	V

Note: Exceeding these ratings could cause damage to the sensor. All voltages are with respect to ground. Currents are positive into, negative out of the specified terminal.

Recommended Operating Conditions

Description	Symbol	Min.	Typ.	Max.	Unit
Supply Voltage	VDD	1.7		3.6	V
LED Supply Voltage	V _{LED}	2.3		4.5	V
Interface signal input high	V _{I2Chigh}	1.5		VDD	V
Interface signal input low	V _{I2Clow}	0		0.4	V
Operating Temperature	T _{ope}	-40		85	°C

Electrical & Optical Specifications

All specifications are at VDD = 2.8V, T_{ope} = 25°C, unless otherwise noted.

Parameter	Min.	Typ.	Max.	Unit	Condition
Supply Current		150	260	uA	Active mode
ALS Active Supply Current		110		uA	Max. duty cycle, Vdd=2.8V, Gain3
PS Active Supply Current		95		uA	Max. duty cycle, Vdd=2.8V
Standby Current		1		uA	Shutdown Mode
Wakeup Time from Standby		5	10	ms	From Standby to Active mode where measurement can start

Characteristics Ambient Light

Parameter	Min.	Typ.	Max.	Unit	Condition
ALS Resolution	16		20	Bit	Programmable for 16, 17, 18, 19, 20 Bit
ALS Lux accuracy	-10		+10	%	
Dark Level Count		0	5	Count	0 Lux, 18-bit resolution

Optical Sensor LTR-X1303-039

Min. Integration time	50	400	ms	With 50/60Hz Rejection
50/60 Hz flicker noise error	-5	+5	%	
ALS Gain	1	18		Programmable to 1x,3x,6x,9x,18x
Sensitivity (White LED, CCT = 5000 K)		5.8	Count/lux	ALS Gain = 3x, Integration time = 100ms
Sensitivity (White LED, CCT = 5000 K)		35	Count/lux	ALS Gain = 18x, Integration time = 100ms
Sensitivity (White LED, CCT = 5000 K)		140	Count/lux	ALS Gain = 18x, Integration time = 400ms

Characteristics Proximity Sensor

Parameter	Min.	Typ.	Max.	Unit	Condition
PS Resolution	8		11	Bit	
Sensitivity Range		940		nm	
Detection Distance		10		cm	No window, 32 pulses, 60kHz, 100mA, 18% Gray Card
LED Pulse Current	2.5		125	mA	Configurable for 2.5,5,10,25,50,75,100 & 125mA
LED Pulse Frequency	60		100	kHz	
LED Duty Cycle		50		%	
Number of LED Pulses	1		255	Pulses	
Ambient Light Suppression			100	klux	Direct sunlight

Typical Device Parameter

(VDD = 2.8V, Ta=25°C, Default power-up settings, unless otherwise noted)

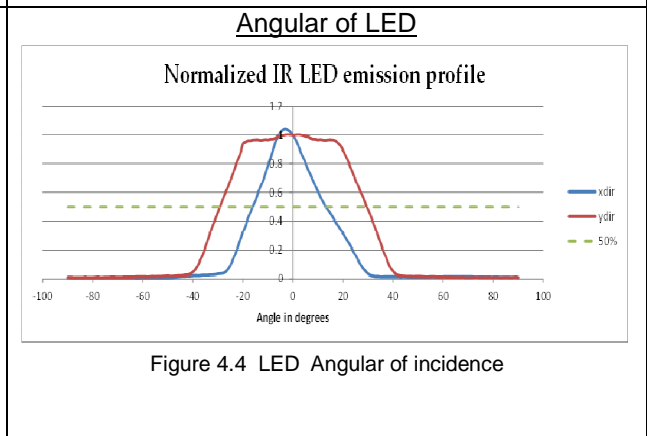
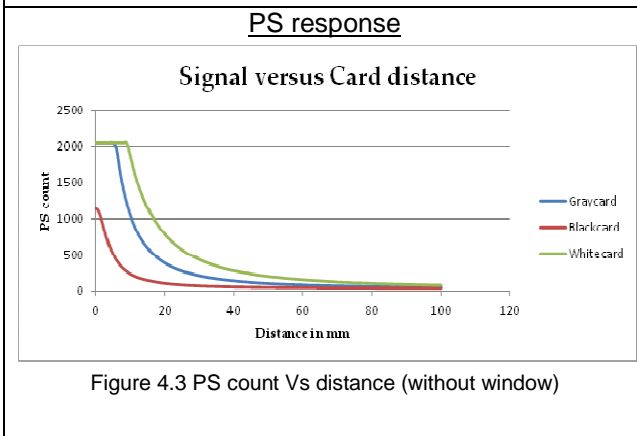
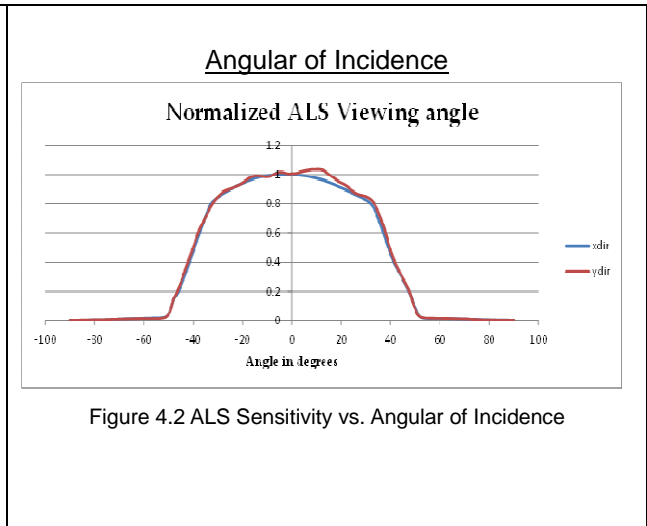
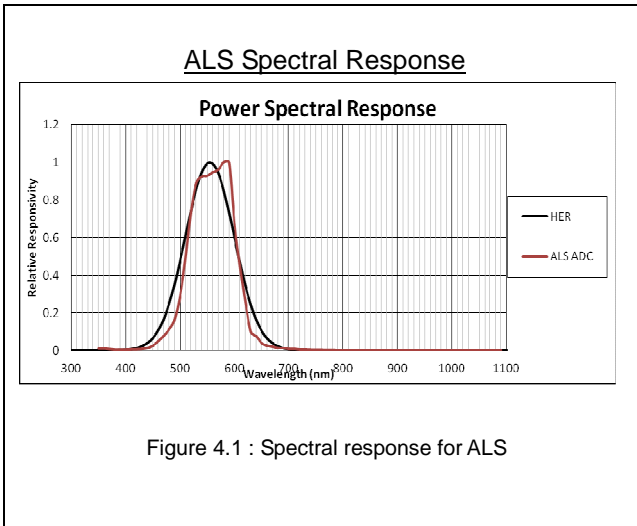

Optical Sensor LTR-X1303-039

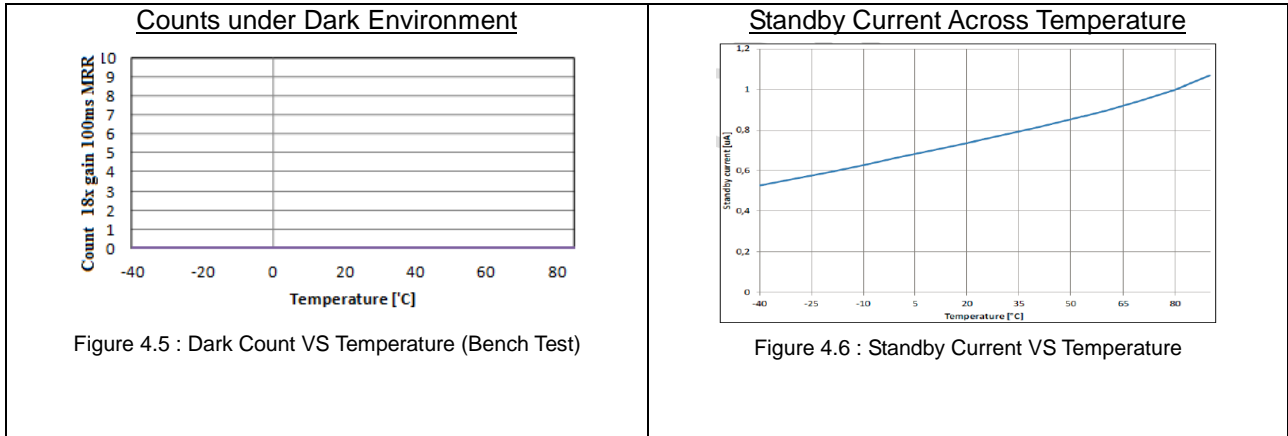

AC Electrical Characteristics

All specifications are at VBus = 1.7V, T_{ope} = 25°C, unless otherwise noted.

Parameter	Symbol	Min.	Max.	Unit
SCL clock frequency	f_{SCL}	1	400	kHz
Bus free time between a STOP and START condition	t_{BUF}	1.3		µs
Hold time (repeated) START condition. After this period, the first clock pulse is generated	$t_{HD;STA}$	0.6		µs
LOW period of the SCL clock	t_{LOW}	1.3		µs
HIGH period of the SCL clock	t_{HIGH}	0.6		µs
Set-up time for a repeated START condition	$t_{SU;STA}$	0.6		µs
Set-up time for STOP condition	$t_{SU;STO}$	0.6		µs
Rise time of both SDA and SCL signals	t_r	--	300	ns
Fall time of both SDA and SCL signals	t_f	--	300	ns
Data hold time	$t_{HD;DAT}$	0		µs
Data setup time	$t_{SU;DAT}$	100		ns
Pulse width of spikes which must be suppressed by the input filter	t_{SP}	0	50	ns

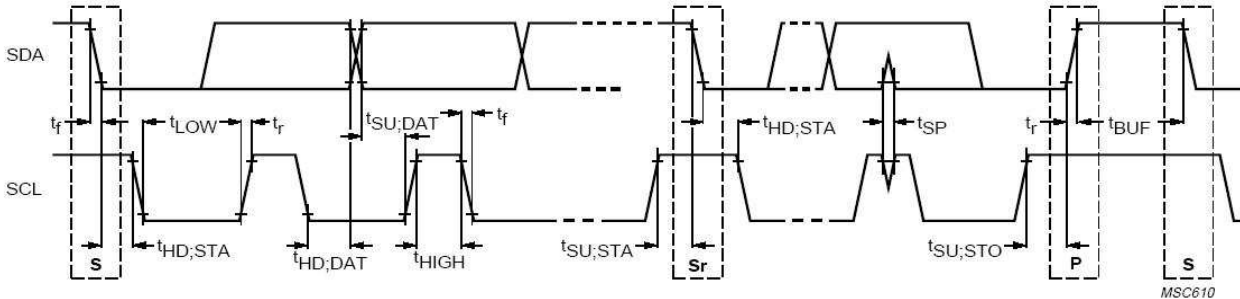

Definition of timing for I²C bus

9. Principles of Operation

I²C Protocols

- I²C Write Protocol (type 1):

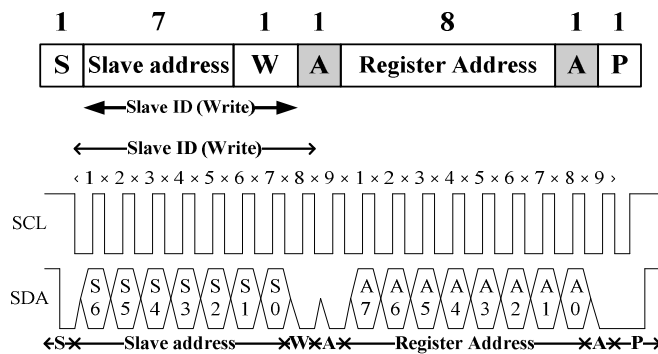

- I²C Write Protocol (type 2):

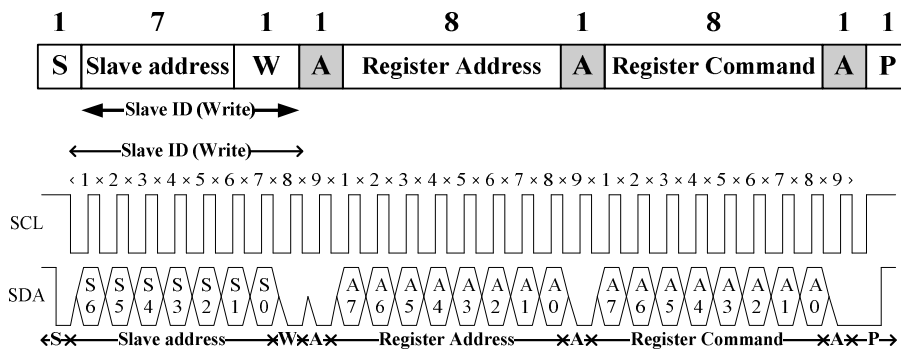

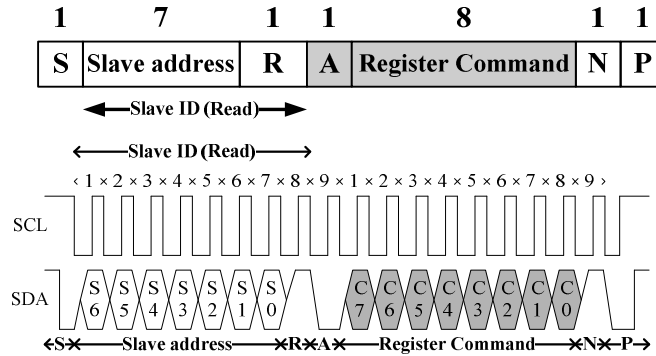

- I²C Read Protocol:

Optical Sensor LTR-X1303-039

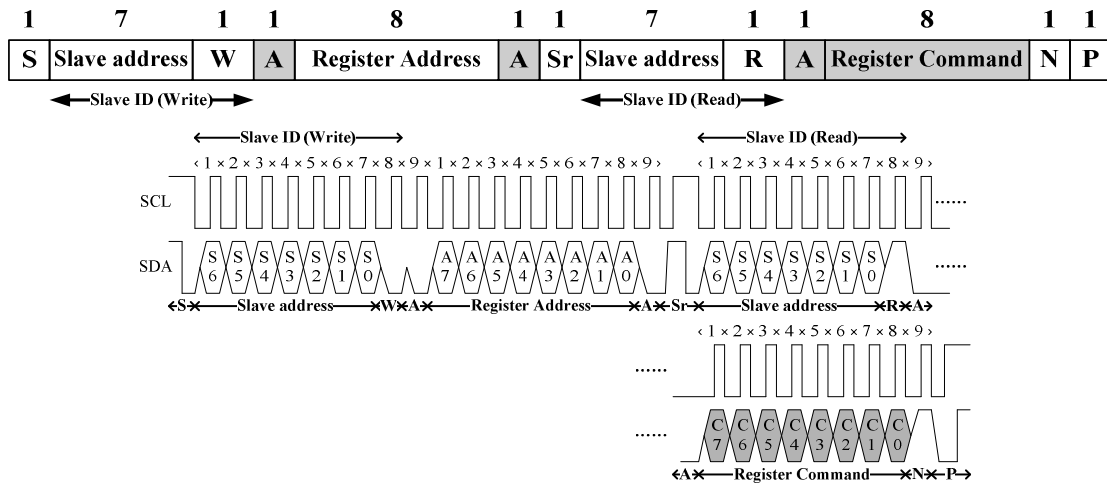

I²C Read (Combined format) Protocol:



A Acknowledge (0 for an ACK)
S Start condition
P Stop condition
W Write (0 for writing)
 Slave-to-master

N Non-Acknowledge (1 for an NACK)
Sr Repeated Start condition
R Read (1 for read)
 Master-to-Slave

I²C Slave Address

The 7 bits slave address for this sensor is 0x53H. A read/write bit should be appended to the slave address by the master device to properly communicate with the sensor.

I ² C Slave Address									
Command Type	(0x53H)							W/R	value
	Bit7	Bit6	Bit5	Bit4	Bit3	Bit2	Bit1	Bit0	
Write	1	0	1	0	0	1	1	0	0xA6H
Read	1	0	1	0	0	1	1	1	0xA7H

Register Set

Addr	R / W	Register Name	Description	Reset Value
0x00	RW	MAIN_CTRL	ALS, PS operation mode control, SW reset	0x00
0x01	R/W	PS_LED	PS LED settings	0x36
0x02	R/W	PS_PULSES	PS number of LED pulses	0x08
0x03	R/W	PS_MEAS_RATE	PS measurement rate in active mode	0x45
0x04	R/W	ALS_MEAS_RATE	ALS measurement rate and resolution in Active Mode	0x22
0x05	R/W	ALS_GAIN	ALS analog Gain	0x01
0x06	R	PART_ID	Part number ID and revision ID	0xB1
0x07	R	MAIN_STATUS	Power-On status, Interrupt status, Data status	0x20
0x08	R	PS_DATA_0	PS measurement data, least significant bits	0x00
0x09	R	PS_DATA_1	PS measurement data, most significant bits, and overflow	0x00
0x0D	R	ALS_DATA_0	ALS ADC measurement data, LSB	0x00
0x0E	R	ALS_DATA_1	ALS ADC measurement data	0x00
0x0F	R	ALS_DATA_2	ALS ADC measurement data, MSB	0x00
0x19	R/W	INT_CFG	Interrupt configuration	0x10
0x1A	R/W	INT_PST	Interrupt persist setting	0x00
0x1B	R/W	PS_THRES_UP_0	PS interrupt upper threshold, LSB	0xFF
0x1C	R/W	PS_THRES_UP_1	PS interrupt upper threshold, MSB	0x07
0x1D	R/W	PS_THRES_LOW_0	PS interrupt lower threshold, LSB	0x00
0x1E	R/W	PS_THRES_LOW_1	PS interrupt lower threshold, MSB	0x00
0x1F	R/W	PS_CAN_0	PS intelligent cancellation level setting, LSB	0x00
0x20	R/W	PS_CAN_1	PS intelligent cancellation level setting, MSB	0x00
0x21	R/W	ALS_THRES_UP_0	ALS interrupt upper threshold, LSB	0xFF
0x22	R/W	ALS_THRES_UP_1	ALS interrupt upper threshold, intervening bits	0xFF
0x23	R/W	ALS_THRES_UP_2	ALS interrupt upper threshold, MSB	0x0F
0x24	R/W	ALS_THRES_LOW_0	ALS interrupt lower threshold, LSB	0x00
0x25	R/W	ALS_THRES_LOW_1	ALS interrupt lower threshold, intervening bits	0x00
0x26	R/W	ALS_THRES_LOW_2	ALS interrupt lower threshold, MSB	0x00

MAIN_CTRL Register (0x00) (Read/Write)

This register controls the operation modes of ALS, which can be set to either standby or active mode. When writing to this register, it will cause a stop to any ongoing measurements (both ALS and PS) and start new measurement.

0x00	MAIN_CTRL (default = 0x00)							
	B7	B6	B5	B4	B3	B2	B1	B0
	Reserved			Software Reset	Reserved	Reserved	ALS Enable	PS Enable

Field	Bits	Default	Description	
Reserved	7:5	000	--	--
SW Reset	4	0	0	Software reset is NOT triggered (default)

Optical Sensor LTR-X1303-039

			1	Software reset is triggered
Reserved	2:3	00	--	--
ALS Enable	1	0	0	ALS standby(default)
			1	ALS active
PS Enable	0	0	0	PS standby(default)
			1	PS active

PS_LED Register (0x01) (Read/Write)

This register controls the LED driving current and the LED pulse modulation frequency.

0x01	PS_LED (default = 0x36)							
	B7	B6	B5	B4	B3	B2	B1	B0
	<i>Reserved</i>	<i>LED Pulse Modulation Frequency</i>			<i>Reserved</i>	<i>LED Current</i>		

Field	Bits	Default	Description	
Reserved	7	0	-	-
LED pulse modulation Frequency	4:6	011	000	Reserved
			001	Reserved
			010	Reserved
			011	LED pulse period = 60kHz(default)
			100	LED pulse period = 70kHz
			101	LED pulse period = 80kHz
			110	LED pulse period = 90kHz
			111	LED pulse period = 100kHz
Reserved	3	0	-	-
LED current	2:0	110	000	LED pulsed current level = 2.5mA
			001	LED pulsed current level = 5.0mA
			010	LED pulsed current level = 10mA
			011	LED pulsed current level = 25mA
			100	LED pulsed current level = 50mA
			101	LED pulsed current level = 75mA
			110	LED pulsed current level = 100mA (default)
			111	LED pulsed current level = 125mA

PS_PULSES Register (0x02) (Read/Write)

This register controls number of PS LED pulses emitted.

0x02	PS_PULSES (default = 0x08)							
	B7	B6	B5	B4	B3	B2	B1	B0
	<i>Number of LED Pulses</i>							

Field	Bits	Default	Description	
Number of LED pulses	7:0	0000 1000	00 0000	0 pulse (no light emission)
			00 0001	1 pulse
			00 0010	2 pulses
		
			00 1000	8 pulses (default)
		
			10 0000	32 pulses
			1111 1111	255 pulses

PS_MEAS_RATE Register (0x03) (Read/Write)

This register controls the timing of the periodic measurements of the PS during active mode. When the measurement rate is programmed to be faster than possible for the programmed ADC measurement, the rate will be lowered than programmed (maximum speed).

0x03	PS_MEAS_RATE (default = 0x45)							
	B7	B6	B5	B4	B3	B2	B1	B0
	0	1	0	<i>PS Resolution/Bit Width</i>		<i>PS Measurement Rate</i>		

Field	Bits	Default	Description	
Reserved	7:5	010	Must write 010	
PS Resolution/Bit Width	4:3	00	00	8 bit(default)
			01	9 bit
			10	10 bit
			11	11 bit
PS Measurement Rate	2:0	101	000	Reserved
			001	6.25ms
			010	12.5ms
			011	25 ms

Optical Sensor LTR-X1303-039

			100	50ms
			101	100ms(default)
			110	200ms
			111	400ms

ALS_MEAS_RATE Register (0x04) (Read/Write)

This register controls ALS measurement resolution, Gain setting and measurement rate. When the measurement rate is programmed to be faster than possible for the programmed ADC measurement, the rate will be lowered than programmed (maximum speed).

0x04	ALS_MEAS_RATE (default = 0x22)							
	B7	B6	B5	B4	B3	B2	B1	B0
	<i>Reserved</i>	<i>ALS/C Resolution/Bit Width</i>			<i>Reserved</i>	<i>ALS Measurement Rate</i>		

Field	Bits	Default	Description	
Reserved	7	0	--	--
ALS Resolution	6:4	010	000	20 Bit, Conversion time = 400ms
			001	19 Bit, Conversion time = 200ms
			010	18 Bit, Conversion time = 100ms(default)
			011	17 Bit, Conversion time = 50ms
			100	16 Bit, Conversion time = 25ms
			101/110/111	Reserved
Reserved	3	0	--	--
ALS Measurement Rate	2:0	010	000	25ms
			001	50ms
			010	100ms (default)
			011	500ms
			101	1000ms
			110/111	2000ms

ALS_GAIN Register (0x05) (Read/Write)

This register controls ALS measurement Gain Range.

0x05	ALS_GAIN (default = 0x01)							
	B7	B6	B5	B4	B3	B2	B1	B0
	<i>Reserved</i>					<i>ALS Gain Range</i>		

Field	Bits	Default	Description	
Reserved	7:3	00000	--	--
ALS Gain Range	2:0	001	000	Gain Range: 1
			001	Gain Range: 3 (default)
			010	Gain Range: 6
			011	Gain Range: 9
			100	Gain Range: 18

PART_ID Register (0x06) (Read Only)

This register defines the part number and revision identification of the sensor.

0x06	PART_ID (default = 0xB1)							
	B7	B6	B5	B4	B3	B2	B1	B0
	<i>Part Number ID</i>				<i>Revision ID</i>			

Field	Bits	Default	Description
Part Number ID	7:4	1011	Part Number ID
Revision ID	3:0	0001	Revision ID

MAIN_STATUS Register (0x07) (Read Only)

This register stores the information about the ALS and PS interrupts and data status. The interrupt status in Bit 4 and Bit 1 determines if the ALS and PS interrupt criteria are met in Normal Interrupt Mode. It triggers when the ALS and/or PS data is above the upper or below the lower threshold for a specified number of consecutive measurements in respective interrupt persist settings. This register also provides PS logic signal status, which is used for indicating whether the detected object is near (PS data larger than PS upper threshold settings) or far (PS data smaller than PS lower threshold settings). For details interrupt behavior, refer to Section 10.

0x07	MAIN_STATUS (default = 0x20)							
	B7	B6	B5	B4	B3	B2	B1	B0

Optical Sensor LTR-X1303-039

	<i>Reserved</i>	<i>Power ON Status</i>	<i>ALS Interrupt Status</i>	<i>ALS Data Status</i>	<i>PS Logic Signal Status</i>	<i>PS Interrupt Status</i>	<i>PS Data Status</i>
--	-----------------	------------------------	-----------------------------	------------------------	-------------------------------	----------------------------	-----------------------

Field	Bits	Default	Description	
Reserved	7:6	00	--	--
Power On Status	5	0	0	Power on event and All interrupt threshold settings in the registers have been rest to power on default states (either due to part turned on or power supply voltage glitch). Flag is cleared after read.
ALS Interrupt Status	4	0	0	Interrupt is NOT triggered (default)
			1	Interrupt is triggered and will be cleared after read
ALS Data Status	3	0	0	ALS data is old data (Data has been read)
			1	ALS data is new data (Data has not been read and will be cleared after read)
PS Logic Signal Status	2	0	0	Object is far (default)
			1	Object is near
PS Interrupt Status	1	0	0	Interrupt is NOT triggered (default)
			1	Interrupt is triggered and will be cleared after read
PS Data Status	0	0	0	PS data is old data (Data has been read)
			1	PS data is new data (Data has not been read and will be cleared after read)

PS_DATA Register (0x08 / 0x09) (Read Only)

The PS ADC channel data are expressed as an 11-bit data spread over 2 registers. The PS_DATA_0 and PS_DATA_1 registers provide the lower and upper byte respectively. An overflow bit is available to check if the PS data overflows. When I2C read operation is active and points to any of the register address between 0x07 and 0x18, both registers PS_DATA_0 and PS_DATA_1 will be locked until the I2C read operation has been completed or the specified address range is left. New measurement data is stored into temporary registers and the PS_DATA registers will be updated as soon as there is no on-going I2C read operation to the address range 0x07 to 0x18.

0x08	PS_DATA_0 (default = 0x00)							
	B7	B6	B5	B4	B3	B2	B1	B0
	<i>PS Data Low</i>							

Optical Sensor LTR-X1303-039

0x09	PS_DATA_1 (default = 0x00)							
	B7	B6	B5	B4	B3	B2	B1	B0
	<i>Reserved</i>				<i>Overflow</i>	<i>PS Data High</i>		

Field	Address	Bits	Default	Description	
PS Data, Low	0x08	7:0	00000000	--	PS ADC lower byte data
Reserved	0x09	7:4	000	--	--
Overflow	0x09	3	0	0	Valid PS data (default)
				1	Overflow of PS data
PS Data, High	0x09	2:0	000	--	PS ADC upper byte data

ALS_DATA Register (0x0D / 0x0E / 0x0F) (Read Only)

The ALS Channel digital output data are expressed as a 16 to 20 bit unsigned integer data. When I2C read operation is active and points to any of the register address between 0x07 and 0x18, all 3 registers will be locked until the I2C read operation has been completed or the specified address range is left. This is to ensure that the data in the registers is from the same measurement even if an additional measurement cycle ends during the read operation. New measurement data is stored into temporary registers and the ALS_DATA registers will be updated as soon as there is no on-going I2C read operation to the address range 0x07 to 0x18.

0x0D	ALS_DATA_0 (default = 0x00)							
	B7	B6	B5	B4	B3	B2	B1	B0
	<i>ALS DATA, Low</i>							

0x0E	ALS_DATA_1 (default = 0x00)							
	B7	B6	B5	B4	B3	B2	B1	B0
	<i>ALS DATA, Middle</i>							

0x0F	ALS_DATA_2 (default = 0x00)							
	B7	B6	B5	B4	B3	B2	B1	B0
	<i>Reserved</i>				<i>ALS DATA, High</i>			

Optical Sensor LTR-X1303-039

Field	Address	Bits	Default	Description
ALS Data, Low	0x0D	7:0	00000000	ALS Data lower byte data
ALS Data, Middle	0x0E	7:0	00000000	ALS Data Middle byte data
ALS Data, High	0x0F	7:4	0000	Reserved
		3:0	0000	ALS Data Higher byte data

INT_CFG Register (0x19) (Read/Write)

This register controls the operation of the interrupt pin and functions. ALS and PS have independent interrupt signal and both ALS and PS interrupts are active low. PS interrupt is enabled by Bit 0, and it is threshold triggered based. Besides, ALS interrupt is enabled by Bit 2, and its output pin can be selected as either Normal Interrupt Mode or PS Logic Output Mode through Bit 1. Under Normal Interrupt Mode, the edge-triggered interrupt signal output will be maintains at active level until MAIN_STATUS register is read. While for PS Logic Output Mode, the interrupt pin output is updated after every measurement and output state is maintained between measurements.

0x19	INT_CFG (default = 0x10)							
	B7	B6	B5	B4	B3	B2	B1	B0
	Reserved		ALS INT SELECT		Reserved	ALS INT PIN ENABLE	PS OUTPUT MODE	PS INT PIN ENABLE

Field	Bits	Default	Description	
Reserved	7:6	00	--	--
ALS Interrupt Select	4:5	01	00	Reserved
			01	ALS Channel(Default)
Reserved	3	0	0	Must be 0
ALS Interrupt Pin Enable	2	0	0	ALS interrupt disabled (default)
			1	ALS interrupt enabled
PS OUTPUT MODE	1	0	0	Normal Interrupt Mode: After interrupt event, INT output pin maintains active level until MAIN_STATUS register is read (default)
			1	PS Logic Output Mode: INT output pin is updated after every measurement and maintains output state between measurements.
PS Interrupt Pin Enable	0	0	0	PS interrupt enabled (default)
			1	PS interrupt enabled

INT_PST Register (0x1A) (Read/Write)

This register controls the N number of times the measurement data is outside the range defined by the upper and lower threshold limits before asserting the interrupt.

0x1A	INT_PST (default = 0x00)							
	B7	B6	B5	B4	B3	B2	B1	B0
	<i>ALS Persist</i>				<i>PS Persist</i>			

Field	Bits	Default	Description	
ALS Persist	7:4	0000	0000	Every ALS value out of threshold range asserts an interrupt (default)
			0001	2 consecutive ALS values out of threshold range assert an interrupt
		
			1111	16 consecutive ALS values out of threshold range assert an interrupt
PS Persist	3:0	0000	0000	Every PS value out of threshold range asserts an interrupt (default)
			0001	2 consecutive PS values out of threshold range assert an interrupt
		
			1111	16 consecutive PS values out of threshold range assert an interrupt

PS_THRES Register (0x1B / 0x1C / 0x1D / 0x1E) (Read/Write)

The PS_THRES_UP and PS_THRES_LOW registers determines the upper and lower limit of the interrupt threshold value respectively. Interrupt will be triggered if measurement data in PS_DATA registers is exceeding the upper and lower limits.

0x1B	PS_THRES_UP_0 (default = 0xFF)							
	B7	B6	B5	B4	B3	B2	B1	B0
	<i>PS Upper Threshold, Low</i>							

0x1C	PS_THRES_UP_1 (default = 0x07)							
------	--------------------------------	--	--	--	--	--	--	--

Optical Sensor LTR-X1303-039

	B7	B6	B5	B4	B3	B2	B1	B0
	Reserved					PS Upper Threshold, High		

0x1D	PS_THRES_LOW_0 (default = 0x00)							
	B7	B6	B5	B4	B3	B2	B1	B0
	PS Lower Threshold, Low							

0x1E	PS_THRES_LOW_1 (default = 0x00)							
	B7	B6	B5	B4	B3	B2	B1	B0
	Reserved					PS Lower Threshold, High		

Field	Address	Bits	Default	Description
PS Upper Threshold, Low	0x1B	7:0	11111111	PS Upper Interrupt Threshold, Low byte
Reserved	0x1C	7:3	00000	--
PS Upper Threshold, High	0x1C	2:0	111	PS Upper Interrupt Threshold, High byte
PS Lower Threshold, Low	0x1D	7:0	00000000	PS Lower Interrupt Threshold, Low byte
Reserved	0x1E	7:3	00000	--
PS Lower Threshold, High	0x1E	2:0	000	PS Lower Interrupt Threshold, High byte

PS_CAN Register (0x1F / 0x20) (Read/Write)

This register defines the offset compensation value for proximity offsets caused by device variations, optical crosstalk and other environment factors. This register sets the PS cancellation value to be subtracted from the measured PS data before the data is transferred to the PS_DATA registers.

0x1F	PS_CAN_0 (default = 0x00)							
	B7	B6	B5	B4	B3	B2	B1	B0
	PS Cancellation Level, Low							

Optical Sensor LTR-X1303-039

0x20	PS_CAN_1 (default = 0x00)							
	B7	B6	B5	B4	B3	B2	B1	B0
	<i>Reserved</i>					<i>PS Cancellation Level, High</i>		

Field	Address	Bits	Default	Description
PS Cancellation Level, Low	0x1F	7:0	00000000	PS Cancellation Level, Low byte
Reserved	0x20	7:3	00000	--
PS Cancellation Level, High	0x20	2:0	000	PS Cancellation Level, High byte

ALS_THRES Register (0x21 / 0x22 / 0x23 / 0x24 / 0x25 / 0x26) (Read/Write)

The ALS_THRES_UP (up to 20-bits) and ALS_THRES_LOW (up to 20-bits) registers determines the upper and lower limit of the interrupt threshold value respectively. Interrupt will be triggered if measurement data in ALS_DATA is exceeding the upper and lower limits.

0x21	ALS_THRES_UP_0 (default = 0xFF)							
	B7	B6	B5	B4	B3	B2	B1	B0
	<i>ALS Upper Threshold, Low</i>							

0x22	ALS_THRES_UP_1 (default = 0xFF)							
	B7	B6	B5	B4	B3	B2	B1	B0
	<i>ALS Upper Threshold, Mid</i>							

0x23	ALS_THRES_UP_2 (default = 0x0F)							
	B7	B6	B5	B4	B3	B2	B1	B0
	<i>Reserved</i>				<i>ALS Upper Threshold, High</i>			

0x24	ALS_THRES_LOW_0 (default = 0x00)							
	B7	B6	B5	B4	B3	B2	B1	B0
	<i>ALS Lower Threshold, Low</i>							

Optical Sensor LTR-X1303-039

0x25	ALS_THRES_LOW_1 (default = 0x00)							
	B7	B6	B5	B4	B3	B2	B1	B0
	<i>ALS Lower Threshold, Mid</i>							

0x26	ALS_THRES_LOW_2 (default = 0x00)							
	B7	B6	B5	B4	B3	B2	B1	B0
	<i>Reserved</i>				<i>ALS Lower Threshold, High</i>			

Field	Address	Bits	Default	Description
ALS Upper Threshold, Low	0x21	7:0	11111111	ALS upper interrupt threshold, Low byte
ALS Upper Threshold, Mid	0x22	7:0	11111111	ALS upper interrupt threshold, Mid byte
ALS Upper Threshold, High	0x23	7:4	0000	Reserved
		3:0	1111	ALS upper interrupt threshold, High byte
ALS Lower Threshold, Low	0x24	7:0	00000000	ALS lower interrupt threshold, Low byte
ALS Lower Threshold, Mid	0x25	7:0	00000000	ALS lower interrupt threshold, Mid byte
ALS Lower Threshold, High	0x26	7:4	0000	Reserved
		3:0	0000	ALS lower interrupt threshold, High byte

10. Application Information

10.1 Lux Formula

Lux_Calc is the calculated lux reading and ALS DATA is the digital representation (output ADC) of ambient light level stored in the registers (Address: 0x0D-0x0F) regardless of light sources.

For no window (Clear window)

$$LUX_{Calc} = \frac{0.51 * ALS_{DATA}}{GAIN * INT}$$

For device under window (eg: Tinted window)

Window Factor is needed when device under Window glass with coated tinted ink. This is to compensate the light loss due to the lower transmission rate of the window glass.

$$LUX_{Calc} = \frac{0.51 * ALS_{DATA}}{GAIN * INT} * WindowFactor$$

Where:

ALS Gain	GAIN
X1	1
X3	3
X6	6
X9	9
X18	18

Resolution (bit) / Integration Time (ms)	INT
16-bit, 25ms	0.25
17-bit, 50ms	0.5
18-bit, 100ms	1
19-bit, 200ms	2
20-bit, 400ms	4

10.2 Device Operation (State Machine and Interrupt Features)

State Machine

Below diagram is the main state machine of LTR-X1303-039.

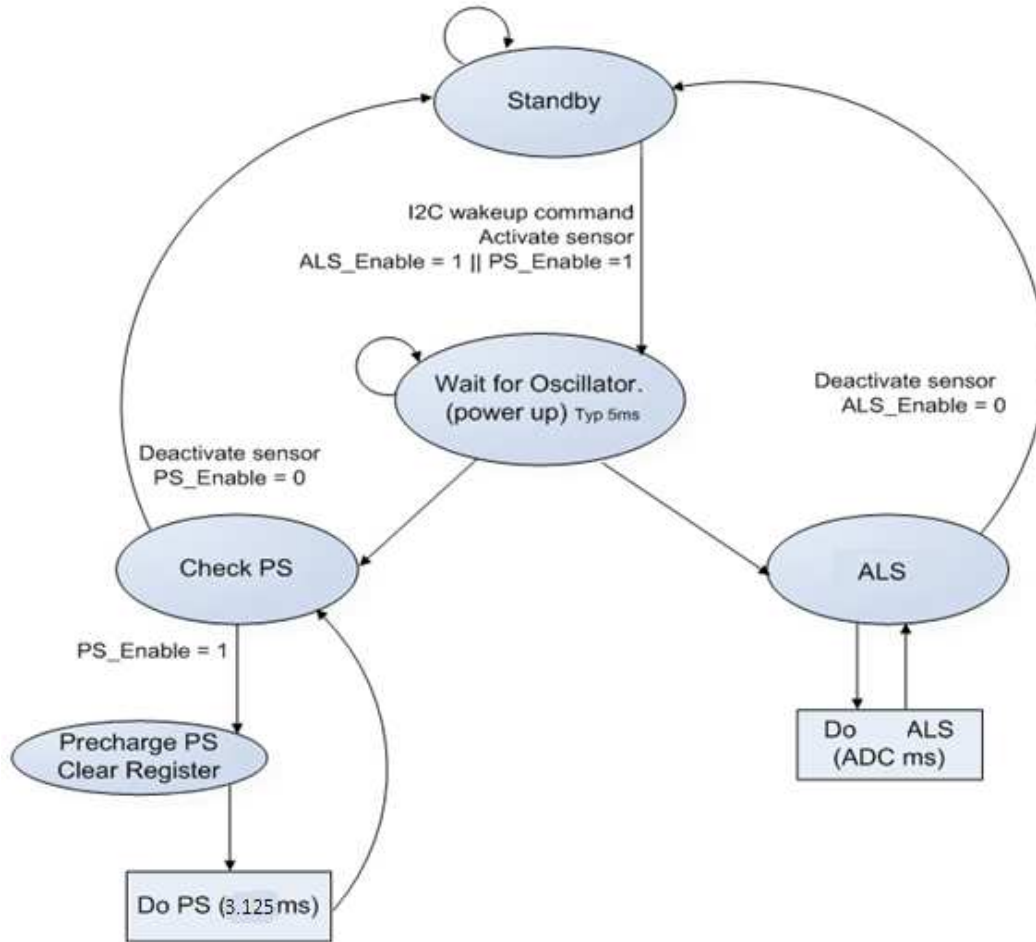

During the ALS and PS Operation, ALS measurements can be activated by setting the ALS_Enable bit to 1, and PS measurement can be activated by setting the PS_Enable bit to 1. As soon as the PS and/or the ALS sensors become activated through an I2C command, the internal support blocks are powered on. Once the voltages and currents are settled (typically after 5ms), the state machine checks for trigger events from a measurement scheduler to start ALS or PS conversions according to the selected measurement repeat rates. Once PS_Enable or ALS_Enable is changed back to 0, a running conversion on the respective channel will be completed and the relevant ADCs and support blocks will move to power-down state.

Interrupt Features

This device generates independent ALS and PS interrupt signals that can be multiplexed and output to the INT output pin. The interrupt conditions are always evaluated after completion of a new conversion of the ALS and PS channels. The PS Logic Mode has priority over any other interrupt signal. If selected (PS Logic Mode = 1), no ALS interrupt can be signaled at the INT pad. ALS and PS interrupts as well as PS Logic Mode are active low at the INT pin.

Optical Sensor LTR-X1303-039

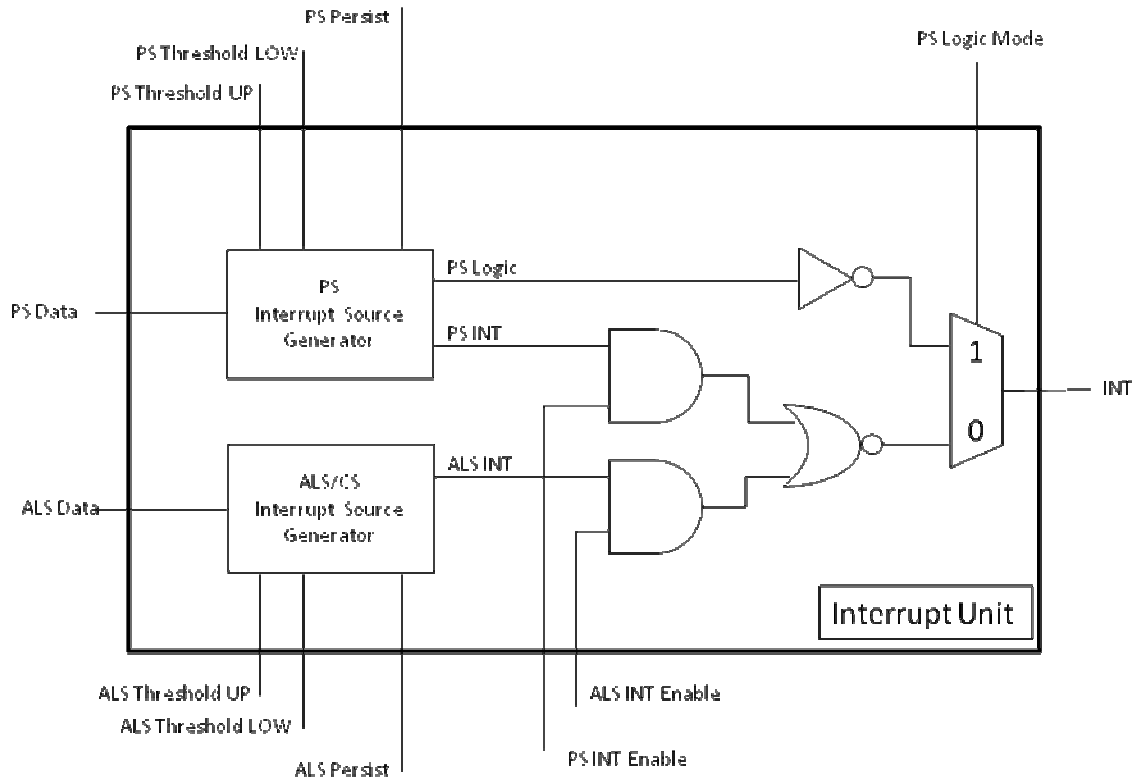

ALS Interrupt

The ALS interrupt is enabled by Bit 2 (ALS INT Pin Enabled) of INT_CFG register (0x19). The ALS interrupt source is ALS channel. The INT is set when the data of the selected interrupt source is above the upper or below the lower threshold for a specified number of consecutive measurements set in ALS Persist in INT_PST register (0x1A). The Interrupt signal is also stored in MAIN_STATUS register (0x07) as flag bit in Bit 4 (ALS INT Status). This status flag bit is cleared by reading the MAIN_STATUS register. A cleared flag will also clear the interrupt signal on the INT pin.

PS Interrupt

The PS interrupt is enabled by Bit 0 (PS Interrupt Pin Enable). It triggers when the PS conversion result is above the upper or below PS threshold for a specified number of consecutive measurements set in PS Persist in INT_PST register (0x1A). The PS Logic Signal, Bit 2 of MAIN_STATUS register (0x07), is set to 0 when the PS data is below the lower PS threshold and it set to 1 if the PS data is above the upper PS threshold.

There are two options to indicate a PS interrupt signal on the INT pin: as a continuous logic signal or as an edge-triggered interrupt signal, which is cleared with the next read-out of the MAIN-STATUS register. The PS interrupt signal is also stored in MAIN_STATUS register (0x07) as flag bit in Bit 1 (PS INT Status). This status flag bit is cleared by reading the MAIN_STATUS register. The PS interrupt behavior is as shown below.

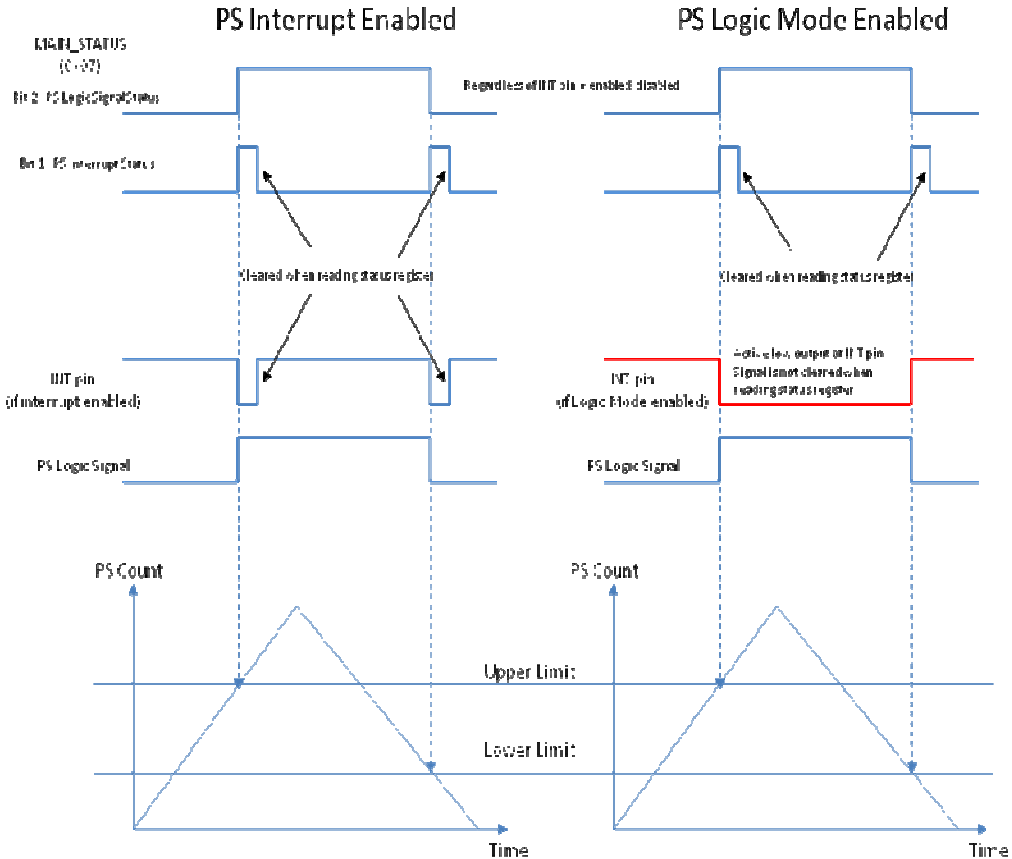

11. Pseudo Codes Examples

Slave address
Slave_Addr = 0xA6

MAIN_CTRL Register
// This defines the operating modes of the ALS
// Default settings is 0x00 (ALS standby, PS standby)

Register_Addr = 0x00 // MAIN_CTRL register
Command = 0x03 // ALS/PS in Active Mode,

WriteByte(Slave_Addr, Register_Addr, Command);

PS_LED Register
// This defines the LED pulse modulation frequency and Peak current.
// Default setting is 0x36 (Pulse Freq = 60kHz, peak current = 100mA).

Register_Addr = 0x01 // PS_LED register
Command = 0x36 // Pulse Freq = 60kHz, Peak Current =100mA

Optical Sensor LTR-X1303-039

```
// Command = 0x46      Pulse Freq = 70kHz, Peak Current =100mA
// Command = 0x44      Pulse Freq = 70kHz, Peak Current = 50mA
// Command = 0x76      Pulse Freq = 100kHz, Peak Current = 100mA
// Command = 0x77      Pulse Freq = 100kHz, Peak Current = 125mA
```

WriteByte(Slave_Addr, Register_Addr, Command)

PS_PULSES Register

// This controls the number of PS LED pulses emitted.
// Default setting of the register is 0x08 (8 Pulses)

```
Register_Addr = 0x02      // PS_PULSES register
Command = 0x08           //
                        // Command = 0x00      8 pulses
                        // Command = 0x04      0 (no light)
                        // Command = 0x20      4 pulses
                        // Command = 0x20      32 pulses
```

WriteByte(Slave_Addr, Register_Addr, Command)

PS_MEAS_RATE Register

//This controls the PS Resolution and measurement rate.
// Default setting of the register is 0x45 (PS Resolution = 8 bit, Measurement Rate = 100ms)

```
Register_Addr = 0x03      // PS_MEAS_RATE register
Command = 0x45           //
                        // Command = 0x47      Resolution = 8 bit, Meas Rate = 100ms
                        // Command = 0x47      Resolution = 8 bit Meas Rate = 400ms
                        // Command = 0x5D      Resolution = 11 bit Meas Rate = 100ms
```

WriteByte(Slave_Addr, Register_Addr, Command)

ALS_MEAS_RATE Register

// This controls the ALS measurement resolution and measurement rate.
// Default setting of the register is 0x22 (Resolution = 18 Bit, Measurement rate of 100ms)

```
Register_Addr = 0x04      // ALS_MEAS_RATE register
Command = 0x41           //
                        // Command =0x25      Resolution = 16 bit, Meas Rate =50ms
                        // Command =0x02      Resolution = 18 bit, Meas Rate =1000ms
                        // Command =0x02      Resolution = 20 bit, Meas Rate =100ms
```

WriteByte(Slave_Addr, Register_Addr, Command)

ALS_GAIN Register

// This controls the ALS Gain Range.
// Default setting of the register is 0x01 (Gain Range = 3)

```
Register_Addr = 0x05      // ALS_GAIN register
Command = 0x00           //
                        // Command =0x04      Gain = 1
                        // Command =0x04      Gain = 18
```

WriteByte(Slave_Addr, Register_Addr, Command)

MAIN_STATUS Register (Read Only)

// This Register contains the information on Interrupt, ALS and PS data status.

```
Register_Addr = 0x07      // MAIN_STATUS register address
Data = ReadByte(Slave_Addr, Register_Addr)
```

```
Power_ON_Status = Data & 0x20      // If 0x20 Part went through power-up event
// If 0x00 Normal
```

```
ALS_Interrupt_Status = Data & 0x10 // If 0x10 Interrupt triggered
// If 0x00 Interrupt condition not fulfilled
```

Optical Sensor LTR-X1303-039

```

ALS_Data_Status = Data & 0x08           // If 0x08 ALS data is new
                                           // If 0x00 Old (previously read) Data
PS_Logic_Signal_Status = Data & 0x04    // If 0x04 Object is near
                                           // If 0x00 Object is far
PS_Interrupt_Status = Data & 0x02       // If 0x02 Interrupt triggered
                                           // If 0x00 Interrupt condition not fulfilled
PS_Data_Status = Data & 0x01           // If 0x01 PS data is new
                                           // If 0x00 Old (previously read) Data

```

PS_DATA Registers (Read Only)

//The register 0x08 contains PS ADC lower byte data.
//The register 0x09 contains PS ADC 3 bits of upper byte data and PS Overflow flag
//These registers should be read as a group, with the lower address being read first.

```

Register_Addr = 0x08                     // PS_DATA0 low byte address
Data0=ReadByte(Slave_Addr, Register_Addr) // Data= PS ADC lower byte data

Register_Addr = 0x09                     // PS_DATA1 high byte address
Data=ReadByte(Slave_Addr, Register_Addr) // Data= PS ADC high byte data
Data1=Data&0x03                          // Mask with 0x03 to extract data

PS_ADC_Data = (Data1 << 8) | Data0       // Shift and combine lower and upper bytes to give 11-bit PS data
Overflow_status = Data & 0x08           // If 0x08 PS Data is overflow
                                           // If 0x00 PS Data is valid

```

CLEAR_DATA Registers (Read Only)

//The register 0x0A contains CLEAR_DATA ADC 0 lower byte data.
//The register 0x0B contains CLEAR_DATA ADC 1 middle byte data.
//The register 0x0C contains CLEAR_DATA ADC 2 upper byte data.
//These registers should be read as a group, with the lower address being read first.

```

Register_Addr = 0x0A                     // CLEAR_DATA_0 low byte address
Data0=ReadByte(Slave_Addr, Register_Addr)

Register_Addr = 0x0B                     // CLEAR_DATA_1 middle byte address
Data1=ReadByte(Slave_Addr, Register_Addr)

Register_Addr = 0x0C                     // CLEAR_DATA_2 upper byte address
Data2=ReadByte(Slave_Addr, Register_Addr)
CLEAR_Data =(Data2<<16)|(Data1 << 8) | Data0
                                           // Shift and combine all register data to get CLEAR ADC Data

```

ALS_DATA Registers (Read Only)

// The register 0x0D contains ALS ADC lower byte data.
// The register 0x0E contains ALS ADC 1 middle byte data.
// The register 0x0F contains ALS ADC 2 upper byte data.
// These registers should be read as a group, with the lower address being read first.

```

Register_Addr = 0x0D                     // ALS_DATA_0 low byte address
Data0=ReadByte(Slave_Addr, Register_Addr)

Register_Addr = 0x0E                     // ALS_DATA_1 middle byte address
Data1=ReadByte(Slave_Addr, Register_Addr)

Register_Addr = 0x0F                     // ALS_DATA_2 upper byte address
Data2=ReadByte(Slave_Addr, Register_Addr)
ALS_ADC_Data =(Data2<<16)|(Data1 << 8) | Data0
                                           // Shift and combine all register data to get ALS ADC Data

```

ALS_DATA_COMP Registers (Read Only)

// The register 0x16 contains ALS_COMP ADC lower byte data.

Optical Sensor LTR-X1303-039

// The register 0x17 contains ALS_COMP ADC 1 middle byte data.
 // The register 0x18 contains ALS_COMP ADC 2 upper byte data.
 // These registers should be read as a group, with the lower address being read first.

```
Register_Addr = 0x16 // ALS_DATA_COMP_0 low byte address
Data0=ReadByte(Slave_Addr, Register_Addr)
Register_Addr = 0x17 // ALS_DATA_COMP_1 middle byte address
Data1=ReadByte(Slave_Addr, Register_Addr)
Register_Addr = 0x18 // ALS_DATA_COMP_2 upper byte address
Data2=ReadByte(Slave_Addr, Register_Addr)
ALS_COMP_ADC_Data =(Data2<<16)|(Data1 << 8) | Data0
// Shift and combine all register data to get ALS_COMP ADC Data
```

INT_CFG Register

//This register controls the operation of the interrupt pins and options to trigger interrupt for ALS and PS.
 //The default value for this INT_CFG register is 0x10 (Interrupts inactive for both ALS and PS)

```
Register_Addr = 0x19 // INT_CFG Register address
Command = 0x15 // Interrupt CH = ALS, ALS Interrupt Enable, Normal trigger mode; PS Interrupt Enable
// Command = 0x17 // Interrupt source CH = ALS, ALS Interrupt Enable, PS Logic Output Mode; PS Interrupt Enable
// Command = 0x05 // Interrupt source CH = CLEAR, ALS Interrupt Enable, Normal Trigger Mode; PS Interrupt Enable
// Command = 0x14 // Interrupt CH = ALS, ALS Interrupt Enable, Normal Trigger Mode; PS Interrupt Disable
// Command = 0x11 // Interrupt CH = ALS, ALS Interrupt Disable, Normal Trigger Mode; PS Interrupt Enable
```

WriteByte(Slave_Addr, Register_Addr, Command)

INTERRUPT_PERSIST Register

// This register sets the ALS and PS persist level.
 // The default setting is 0x00. Interrupt at every ALS and PS reading outside set thresholds.

```
Register_Addr = 0x1A // INT_PST register
Command = 0x00 // Interrupt for every ALS and PS value outside threshold
// Command =0x10 // Subsequent 2 ALS and every PS value, outside threshold range
// Command =0x11 // Subsequent 2 ALS and 2 PS values, outside threshold range
// Command =0x35 // Subsequent 4 ALS and subsequent 6 PS values, outside threshold range
```

WriteByte(Slave_Addr, Register_Addr, Command)

PS_THRES Registers

// The register 0x1B contains PS Interrupt upper threshold lower byte data (PS_THRES_UP_0)
 // The register 0x1C contains PS Interrupt upper threshold upper byte data (PS_THRES_UP_1)
 // The register 0x1D contains PS Interrupt lower threshold lower byte data (PS_THRES_LOW_0)
 // The register 0x1E contains PS Interrupt lower threshold upper byte data (PS_THRES_LOW_1)

// To set PS Upper threshold for Interrupt

Optical Sensor LTR-X1303-039

```
Upper_Threshold_Value=1000 // Example 1000
Data1 = Upper_Threshold_Value >> 8 // Shift right to extract the upper byte
Data0 = Upper_Threshold_Value & 0xFF // Mask to extract lower byte.
Register_Addr = 0x1B // PS_THRES_UP_0 Register address
WriteByte(Slave_Addr, Register_Addr, Data0)
Register_Addr = 0x1C // PS_THRES_UP_1 Register address
WriteByte(Slave_Addr, Register_Addr, Data1)
```

```
// To set PS Lower threshold for Interrupt
Lower_Threshold_Value=100 // Example 100
Data1 = Lower_Threshold_Value >> 8 // Shift right to extract the upper byte
Data0 = Lower_Threshold_Value & 0xFF // Mask to extract lower byte.
Register_Addr = 0x1D // PS_THRES_LOW_0 Register address
WriteByte(Slave_Addr, Register_Addr, Data0)
Register_Addr = 0x1E // PS_THRES_LOW_1 Register address
WriteByte(Slave_Addr, Register_Addr, Data1)
```

PS_CAN Registers

```
//The register 0x1F contains PS cancellation lower byte data (PS_CAN_0)
//The register 0x20 contains 3 bits of PS cancellation upper byte data (PS_CAN_1)
```

```
//To set PS Cancellation Value (0 to 2047)
PS_Cancel_Value=100 // Example 100
Data1 = PS_Cancel_Value >> 8 // Shift right to extract the upper byte
Data0 = PS_Cancel_Value & 0xFF // Mask to extract lower byte.
Register_Addr = 0x1F // PS_CAN_0 Register address
WriteByte(Slave_Addr, Register_Addr, Data0)
Register_Addr = 0x20 // PS_CAN_1 Register address
WriteByte(Slave_Addr, Register_Addr, Data1)
```

ALS_THRES Registers

```
//The register 0x21 contains ALS Interrupt upper threshold lower byte data (ALS_THRES_UP_0)
//The register 0x22 contains ALS Interrupt upper threshold 1 upper byte data (ALS_THRES_UP_1)
//The register 0x23 contains ALS Interrupt upper threshold 2 upper byte data (ALS_THRES_UP_2)
```

```
//The register 0x24 contains ALS Interrupt lower threshold lower byte data (ALS_THRES_LOW_0)
//The register 0x25 contains ALS Interrupt lower threshold 1 upper byte data (ALS_THRES_LOW_1)
//The register 0x26 contains ALS Interrupt lower threshold 2 upper byte data (ALS_THRES_LOW_2)
```

```
// To set ALS Upper threshold for Interrupt
Upper_Threshold_Value=1000 // Example 1000
Data2 = Upper_Threshold_Value >> 16 // Shift right to extract the 2 upper byte
Data1 = Upper_Threshold_Value >> 8 // Shift right to extract the 1 upper byte
Data0 = Upper_Threshold_Value & 0xFF // Mask to extract lower byte.

Register_Addr = 0x21 // ALS_THRES_UP_0 Register address
WriteByte(Slave_Addr, Register_Addr, Data0)
Register_Addr = 0x22 // ALS_THRES_UP_1 Register address
WriteByte(Slave_Addr, Register_Addr, Data1)
Register_Addr = 0x23 // ALS_THRES_UP_2 Register address
WriteByte(Slave_Addr, Register_Addr, Data2)
```

```
// To set ALS Lower threshold for Interrupt
Lower_Threshold_Value=100 // Example 100
Data2 = Lower_Threshold_Value >> 16 // Shift right to extract the 2 upper byte
```

Optical Sensor LTR-X1303-039

```
Data1 = Lower_Threshold_Value >> 8           // Shift right to extract the 1 upper byte
Data0 = Lower_Threshold_Value & 0xFF         // Mask to extract lower byte.
```

```
Register_Addr = 0x24                          // ALS_THRES_LOW_0 Register address
WriteByte(Slave_Addr, Register_Addr, Data0)
Register_Addr = 0x25                          // ALS_THRES_LOW_1 Register address
WriteByte(Slave_Addr, Register_Addr, Data1)
Register_Addr = 0x26                          // ALS_THRES_LOW_2 Register address
WriteByte(Slave_Addr, Register_Addr, Data2)
```

12. Recommended Leadfree Reflow Profile

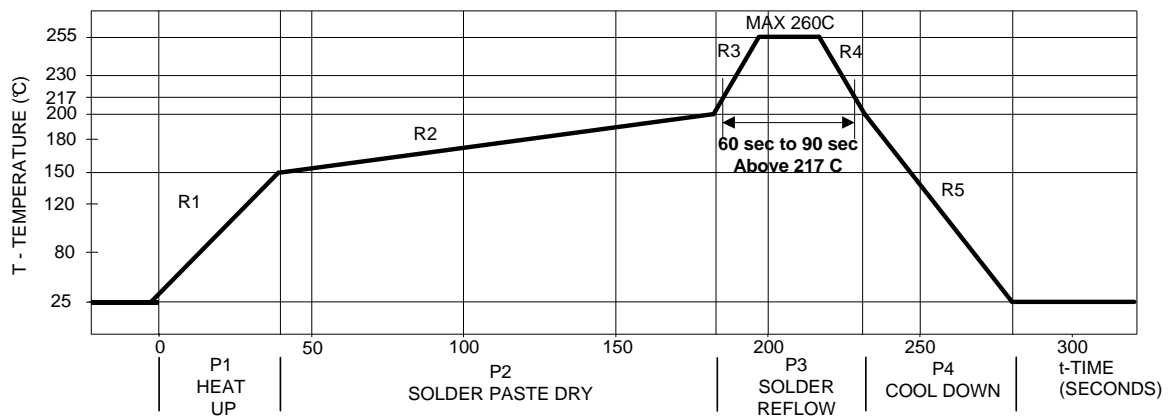

Process Zone	Symbol	ΔT	Maximum ΔT/Δtime or Duration
Heat Up	P1, R1	25°C to 150°C	3°C/s
Solder Paste Dry	P2, R2	150°C to 200°C	100s to 180s
Solder Reflow	P3, R3	200°C to 260°C	3°C/s
	P3, R4	260°C to 200°C	-6°C/s
Cool Down	P4, R5	200°C to 25°C	-6°C/s
Time maintained above liquidus point , 217°C		> 217°C	60s to 90s
Peak Temperature		260°C	-
Time within 5°C of actual Peak Temperature		> 255°C	20s
Time 25°C to Peak Temperature		25°C to 260°C	8mins

It is recommended to perform reflow soldering no more than twice.

13. Moisture Proof Packaging

All LTR-X1303-039 are shipped in moisture proof package. Once opened, moisture absorption begins. This part is compliant to JEDEC J-STD-033A Level 3.

Time from Unsealing to Soldering

After removal from the moisture barrier bag, the parts should be stored at the recommended storage conditions and soldered within seven days. When the moisture barrier bag is opened and the parts are exposed to the recommended storage conditions for more than seven days, the parts must be baked before reflow to prevent damage to the parts.

Recommended Storage Conditions

Storage Temperature	10°C to 30°C
Relative Humidity	Below 60% RH

Baking Conditions

Package	Temperature	Time
In Reels	60°C	48 hours
In Bulk	100°C	4 hours

Baking should only be done once.

14. Recommended Land Pattern and Metal Stencil Aperture

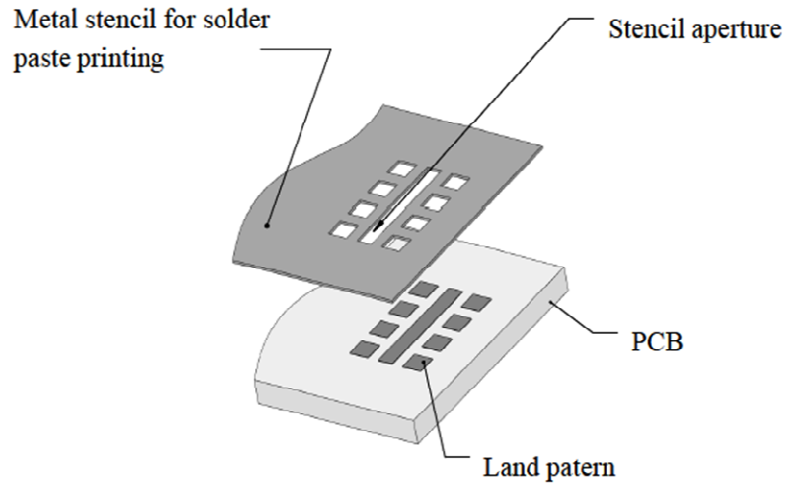

Recommended Land Pattern for LTR-X1303-039

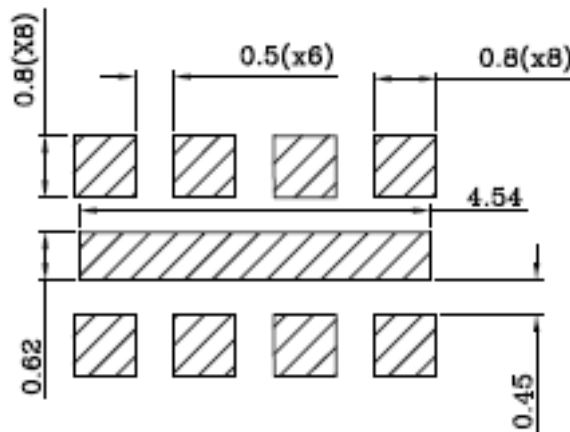

Note: All dimensions are in millimeters

Recommended Metal Stencil Aperture

It is recommended that the metal stencil used for solder paste printing has a thickness (t) of 0.11mm (0.004 inches / 4

Optical Sensor LTR-X1303-039

mils) or 0.127mm (0.005 inches / 5 mils).

The stencil aperture opening for LTR-X1303-039 pads is recommended to be 0.80mm x 0.80mm which has the same dimension as the land patterns. For the center pad stencil aperture opening will be 4.54 mm x 0.62 mm. This is to ensure adequate printed solder paste volume and yet no shorting.

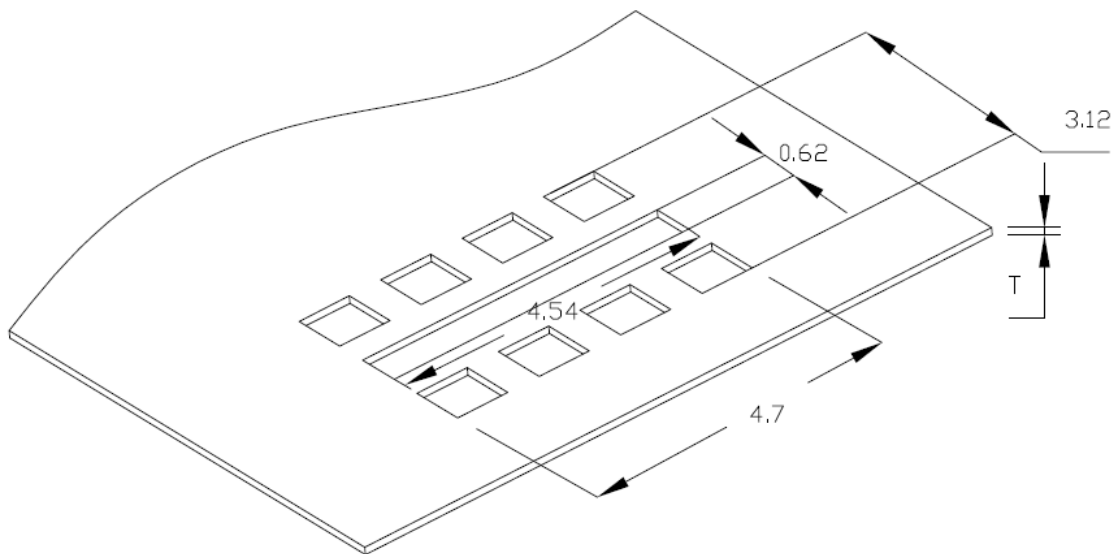

Note:

1. All dimensions are in millimeters

15. Package Dimension for Tape and Reel

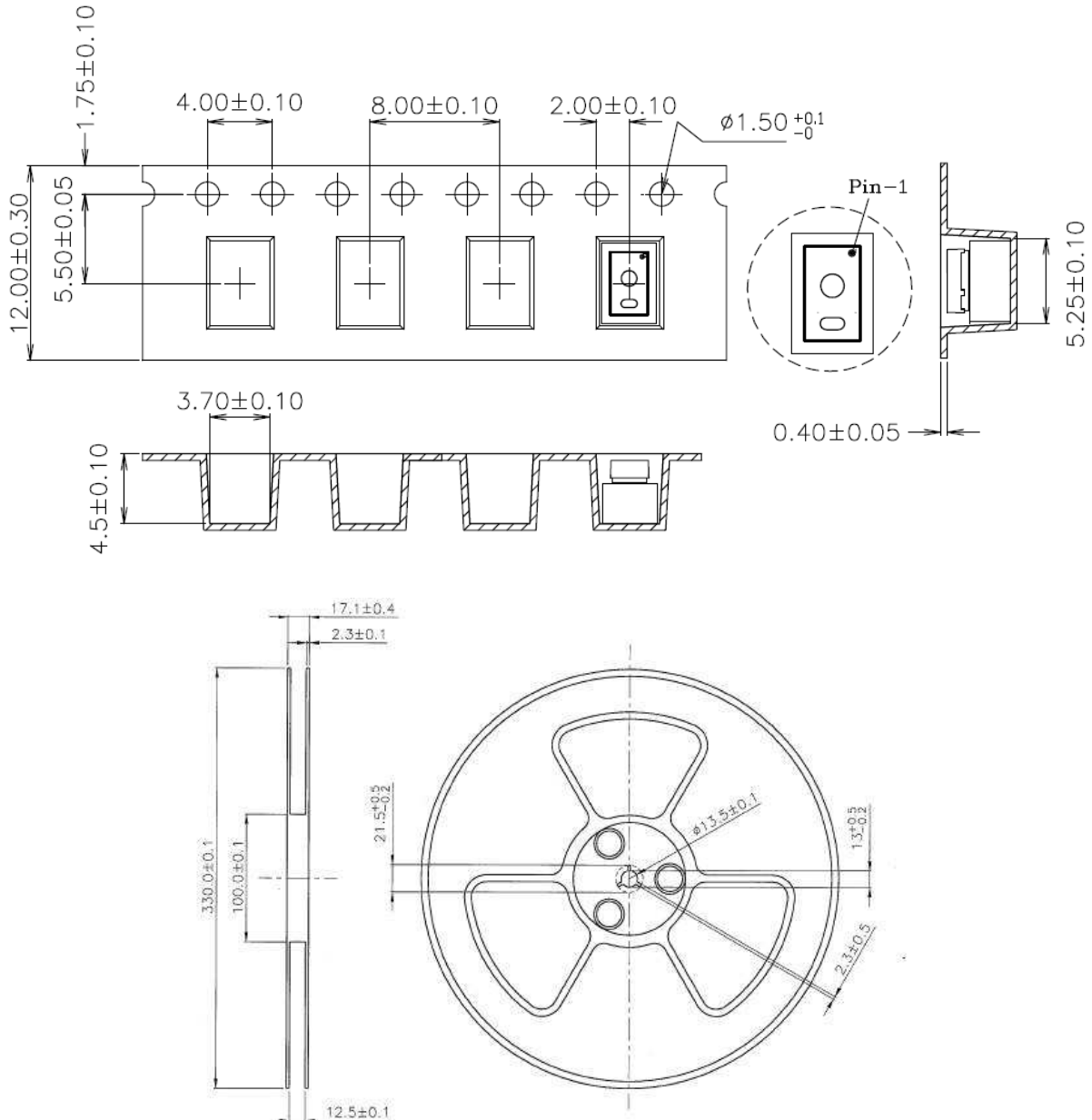

Notes:

1. All dimensions are in millimeters
2. Empty component pockets sealed with top cover tape
3. 13 inch reel – 1500 pieces per reel
4. In accordance with ANSI/EIA 481-1-A-1994 specifications

Optical Sensor LTR-X1303-039

Revision Table:

Version	Update	Page	Date
1.0	Datasheet as created	Total 40	13-Mar-2020
1.1	Updated PS Spec	Total 36	12-Apr-2022
1.2	Update Tape and Reel Spec	Total 36	26-May-2022

单击下面可查看定价，库存，交付和生命周期等信息

[>>Lite-On\(光宝\)](#)