

# MPU-32 SERIES (PGR-6200)

## Motor Protection Unit



### Description

The MPU-32 Motor Protection Unit is used to provide current- and temperature-based protection, metering, and data logging for three-phase low-voltage medium-horsepower induction motors. This relay is ideal for retrofitting and upgrading obsolete or aging motor protection using existing CTs. See the PMA Family of Panel Mount Adapter Kits to replace common obsolete relays.

#### 1 Motor Protection Unit

- Three ac-current inputs
- Earth-leakage-CT input
- Programmable digital input
- 24-Vdc source for digital input
- Programmable 4-20-mA analog output
- On-board temperature-sensor input,
- 100-Ω-Platinum RTD or PTC
- Three programmable output relays
- Local RS-232 communications, optional Network Communications
- PC-interface software (SE-Comm-RIS)
- 4 line x 20 character backlit LCD display
- Keypad for programming and display selection
- 4 LEDs; 1 user programmable

### Simplified Circuit Diagram

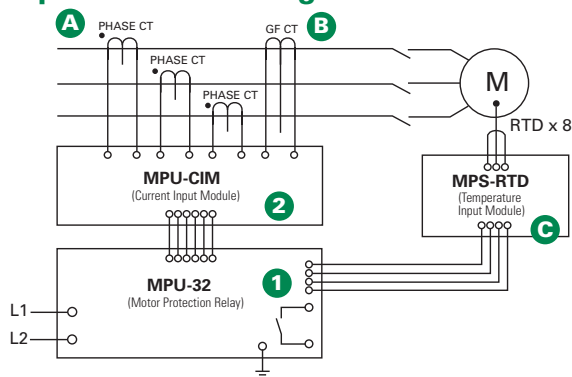

#### 2 Current Input Module (MPU-CIM)

The MPU-CIM Current Input Module is the interface between the MPU-32 relay and the 5-A-secondary, 1-A-secondary, and sensitive current transformers. The MPU-CIM is ordered separately from the MPU-32 and can be surface- or DIN-rail mounted. Wire-clamping terminals are standard but the MPU-CTI is available for those who require ring-tongue terminals.

### Accessories

**A Phase Current Transformers**  
Phase CTs are required to detect phase currents. For upgrade applications, existing CTs can be used.

**B Ground-Fault Current Transformer**  
Optional zero-sequence current transformer detects ground-fault current. Available with 5-A and 30-A primary ratings for low-level pickup.

**C MPS-RTD Temperature Input Module**  
Optional module provides 8 inputs to connect Pt100, Ni100, Ni120, and Cu10 RTDs.

**D MPS-DIF Differential Current Module**  
Optional motor differential protection, compatible with core balance and summation current transformer connections.

### Ordering Information

ORDERING NUMBER	COMMUNICATION
MPU-32-00-00	TIA-232
MPU-32-01-00	TIA-232 & TIA-485
MPU-32-02-00	TIA-232 & DeviceNet™
MPU-32-04-00	TIA-232 & EtherNet/IP™ & Modbus® TCP

NOTE: One of the following is required: MPU-CIM-00-00 Current Input Module, or MPU-CTI-RT-00 Current Input Module with ring-tongue terminals.

ACCESSORIES	REQUIREMENT
Phase CTs	Required
MPS-RTD-01-00	Optional
MPS-DIF-01-00	Optional
MPU-32-SMK	Optional
CA-945	Optional
MPU-16A-Y92A-96N	Optional

# MPU-32 SERIES (PGR-6200)

## Motor Protection Unit

### Features & Benefits

FEATURES	IEEE #	BENEFITS
<b>Overload</b>	49, 51	Extends motor life and prevents insulation failures and fires
<b>Dynamic thermal model</b>		Provides protection through starting, running, and cooling cycles
<b>Communications</b>		Remotely view measured values and event records, reset trips, and access setpoints
<b>Ground fault</b>	50G/N, 51G/N	Prevents catastrophic failures and fires
<b>Current unbalance/ Phase loss/Phase reverse</b>	46	Prevents overheating due to unbalanced phases
<b>RTD temperature</b>	38, 49	RTD temperature protection (MPS-RTD module) for high-ambient or loss-of-ventilation protection
<b>Phase loss/Phase reverse (current)</b>	46	Detects unhealthy supply conditions
<b>Overcurrent</b>	50, 51	Prevents catastrophic failures and fires; extends motor life
<b>Jam</b>		Prevents motor damage by detecting mechanical jams or excessive loading
<b>Undercurrent</b>	37	Detects low level or no-load conditions
<b>PTC overtemperature</b>	49	Overtemperature (PTC) protection for high-ambient or loss-of-ventilation detection
<b>Starts per hour</b>	66	Limits the motor starts per hour to prevent overheating
<b>Differential</b>	87	Optional MPS-DIF module for sensitive winding-fault protection
<b>Reduced overcurrent mode</b>		Minimizes arc-flash hazards during maintenance
<b>Metering</b>		View measured and calculated parameters with on-board display
<b>MPU-CIM</b>		Separate current input module to reduce risk of open-CT hazard and for convenient installation
<b>Analog output</b>		Provides means for metering selectable parameters
<b>Data logging</b>		On-board 100-event recorder for data logging
<b>Conformal coating</b>		Internal circuits are conformally coated to protect against corrosion and moisture

### Wiring Diagram



### Specifications

<b>Protective Functions (IEEE Device Numbers)</b>	Overload (49, 51) Phase reverse (current) (46) Overcurrent (50, 51) Jam Ground fault (50G/N, 51G/N) PTC overtemperature (49)	RTD temperature (38, 49) Unbalance (current) (46) Starts per hour (66) Differential (87) Phase loss (current) (46) Undercurrent (37)
<b>Input Voltage</b>	65-265 Vac, 25 VA; 80-275 Vdc, 25 W	
<b>Power-Up Time</b>	800 ms at 120 Vac	
<b>Ride-Through Time</b>	100 ms minimum	
<b>24-Vdc Source</b>	100 mA maximum	
<b>AC Measurements</b>	True RMS and DFT, Peak, 16 samples/cycle, and positive and negative sequence of fundamental 50, 60 Hz or ASD	
<b>Frequency</b>	50, 60 Hz or ASD	
<b>Output Contacts</b>	Three Form C programmables	
<b>Communications</b>	TIA-232 (standard); TIA-485, DeviceNet™, Ethernet (optional)	
<b>Analog Output</b>	4-20 mA, programmable	
<b>Conformally Coated</b>	Standard feature	
<b>Warranty</b>	10 years	
<b>Mounting (Control Unit)</b>	Panel (standard) Surface (with MPU-32-SMK converter kit)	
<b>(Current Input Module)</b>	DIN, Surface	
<b>Approvals</b>	CSA certified, CE (European Union), UL Recognized, C-Tick (Australian)	

单击下面可查看定价，库存，交付和生命周期等信息

[>>Littelfuse\(美国力特\)](#)