

THD1B410.5S



Description

The THD1B410.5S combines accurate timing circuitry with high power solid-state switching. It can switch motors, lamps, and heaters directly without a contactor. You can reduce labor, component cost, and increase reliability with these small, easy-to-use, timers.

Operation (Delay-on-Make)

Upon application of input voltage, the time delay begins. The output is de-energized before and during the time delay. At the end of the time delay, the output energizes and remains energized until input voltage is removed.

Reset: Removing input voltage resets the time delay and output.

Features & Benefits

FEATURES	BENEFITS
Microcontroller based	Repeat Accuracy +/- 0.5%, Factory calibration +/- 1%
Compact, low cost design	Allows flexibility for OEM applications and reduces labor and component costs
High load currents up to 20A, 200A inrush	Allows direct operation of motors, lamps, and heaters directly without a contactor
Totally solid state and encapsulated	No moving parts to arc and wear out over time and encapsulated to protect against shock, vibration, and humidity
Metalized mounting surface	Facilitates heat transfer for high current applications

Wiring Diagram

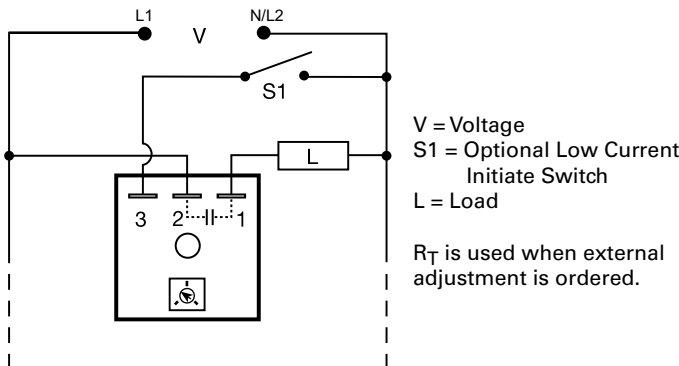

Accessories



P1004-95, P1004-95-X Versa-Pot
Panel mountable, industrial potentiometer recommended for remote time delay adjustment.



P0700-7 Versa-Knob
Designed for 0.25 in. (6.35 mm) shaft of Versa-Pot. Semi-gloss industrial black finish.



P1015-13 (AWG 10/12), P1015-64 (AWG 14/16) Female Quick Connect
These 0.25 in. (6.35 mm) female terminals are constructed with an insulator barrel to provide strain relief.



P1015-18 Quick Connect to Screw Adapter
Screw adapter terminal designed for use with all modules with 0.25 in. (6.35 mm) male quick connect terminals.

THD1 SERIES

Specifications

Time Delay

Range 0.1s - 1000m in 6 adjustable ranges or fixed
Repeat Accuracy ±0.5% or 20ms, whichever is greater

Tolerance (Factory Calibration) ≤ ±1%

Recycle Time ≤ 150ms

Time Delay vs Temp. & Voltage ≤ ±2%

Input

Voltage 24, 120, or 230VAC

Tolerance ±20%

Line Frequency 50/60 Hz

Power Consumption ≤ 2VA

Output

Type Solid state

Form NO, open during timing

Maximum Load Current	Output	Steady State	Inrush**
	A	6A	60A
	B	10A	100A
	C	20A	200A

Minimum Load Current 100mA

Voltage Drop ≅ 2.5V @ rated current

OFF State Leakage Current ≅ 5mA @ 230VAC

Protection

Circuitry Encapsulated

Dielectric Breakdown ≥ 2000V RMS terminals to mounting surface

Insulation Resistance ≥ 100 MΩ

Mechanical

Mounting ** Surface mount with one #10 (M5 x 0.8) screw

Dimensions **H** 50.8 mm (2.0"); **W** 50.8 mm (2.0");

D 38.4 mm (1.51")

Termination 0.25 in. (6.35 mm) male quick connect terminals

Environmental

Operating/Storage

Temperature -40° to 60°C / -40° to 85°C

Humidity 95% relative, non-condensing

Weight ≅ 3.9 oz (111 g)

**Must be bolted to a metal surface using the included heat sink compound. The maximum mounting surface temperature is 90°C. Inrush: Non-repetitive for 16ms.

External Resistance vs. Time Delay

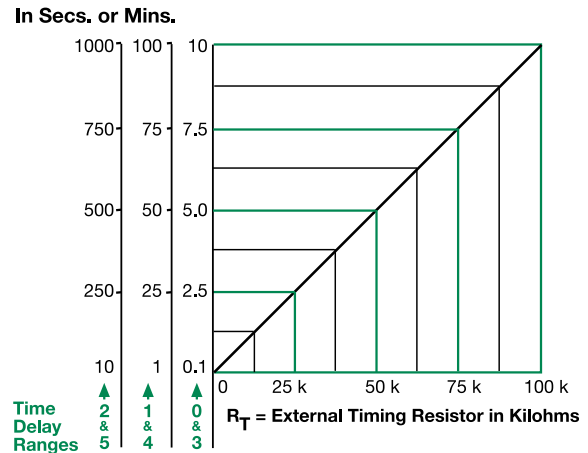

This chart applies to externally adjustable part numbers.

The time delay is adjustable over the time delay range selected by varying the resistance across the R_T terminals; as the resistance increases the time delay increases.

When selecting an external R_T , add the tolerances of the timer and the R_T for the full time range adjustment.

Examples: 1 to 50 S adjustable time delay, select time delay range 1 and a 50 K ohm R_T . For 1 to 100 S use a 100 K ohm R_T .

Function Diagram

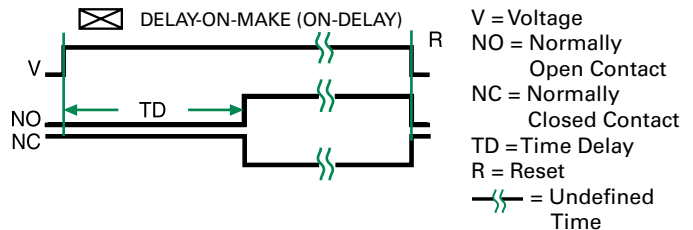

单击下面可查看定价，库存，交付和生命周期等信息

[>>Littelfuse\(美国力特\)](#)