

SP3042 Series 0.35pF 30kV Bidirectional Discrete TVS



Description

The SP3042 includes back-to-back TVS diodes fabricated in a proprietary silicon avalanche technology to provide protection for electronic equipment that may experience destructive electrostatic discharges (ESD). These robust diodes can safely absorb repetitive ESD strikes up to the maximum level specified in IEC 61000-4-2 international standard ($\pm 30\text{kV}$ contact discharge) without performance degradation. The back-to-back configuration provides symmetrical ESD protection for data lines when AC signals are present and the low loading capacitance makes it ideal for protecting high speed data lines such as HDMI, USB2.0, USB3.0 and eSATA.

Pinout

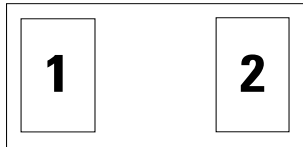

Features

- ESD protection of $\pm 30\text{kV}$ contact discharge, $\pm 30\text{kV}$ air discharge, (IEC 61000-4-2)
- EFT, IEC 61000-4-4, 40A (5/50ns)
- Lightning, IEC 61000-4-5 2nd edition, 2A ($t_p=8/20\mu\text{s}$)
- Low capacitance of 0.35pF @ $V_R=0\text{V}$ (TYP)
- Low leakage current of 100nA at 5.3V (MAX)
- Space efficient 01005 footprint
- Lead free and RoHS compliant

Functional Block Diagram



Applications

- USB 3.0/USB 2.0/MHL
- MIPI Camera and Display
- HDMI 2.0, DisplayPort 1.3, eSATA
- IoT Modules
- Smart Phones
- External Storage
- Ultrabooks, Notebooks
- Tablets, eReaders
- Security Modules

Life Support Note:

Not Intended for Use in Life Support or Life Saving Applications

The products shown herein are not designed for use in life sustaining or life saving applications unless otherwise expressly indicated.

Absolute Maximum Ratings

Symbol	Parameter	Value	Units
P_{PK}	Peak Pulse Power ($t_p=8/20\mu s$)	20	W
I_{PP}	Peak Current ($t_p=8/20\mu s$)	2.0	A
T_{OP}	Operating Temperature	-40 to 125	°C

CAUTION: Stresses above those listed in "Absolute Maximum Ratings" may cause permanent damage to the component. This is a stress only rating and operation of the component at these or any other conditions above those indicated in the operational sections of this specification is not implied.

Electrical Characteristics ($T_{OP}=25^\circ C$)

Parameter	Symbol	Test Conditions	Min	Typ	Max	Units
Reverse Standoff Voltage	V_{RWM}	-	-	-	5.3	V
Breakdown Voltage	V_{BR}	$I_R=1mA$	-	7.8	-	V
Reverse Leakage Current	I_{LEAK}	$V_R=5.3V$	-	-	100	nA
Clamp Voltage ¹	V_C	$I_{PP}=1A, t_p=8/20\mu s, Fwd$	-	12.5	-	V
Dynamic Resistance ²	R_{DYN}	TLP, $t_p=100ns, I/O$ to GND	-	0.5	-	Ω
ESD Withstand Voltage ¹	V_{ESD}	IEC 61000-4-2 (Contact)	± 30	-	-	kV
		IEC 61000-4-2 (Air)	± 30	-	-	kV
Diode Capacitance ¹	C_D	Reverse Bias=0V	-	0.35	0.5	pF

Note:

- Parameter is guaranteed by design and/or component characterization.
- Transmission Line Pulse (TLP) with 100ns width, 2ns rise time, and average window $t_1=70ns$ to $t_2=90ns$

8/20 μs Pulse Waveform

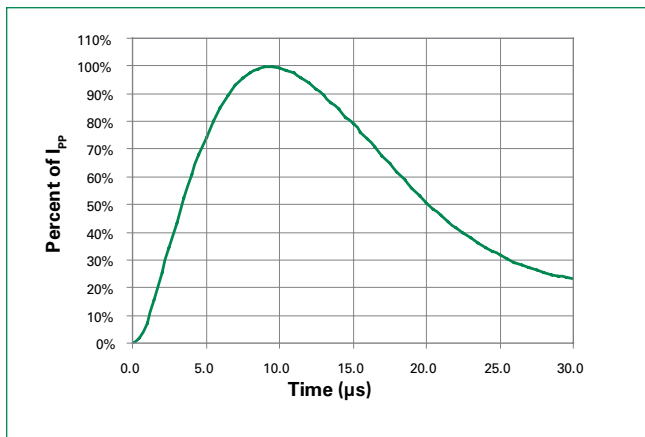

Capacitance vs Reverse Bias

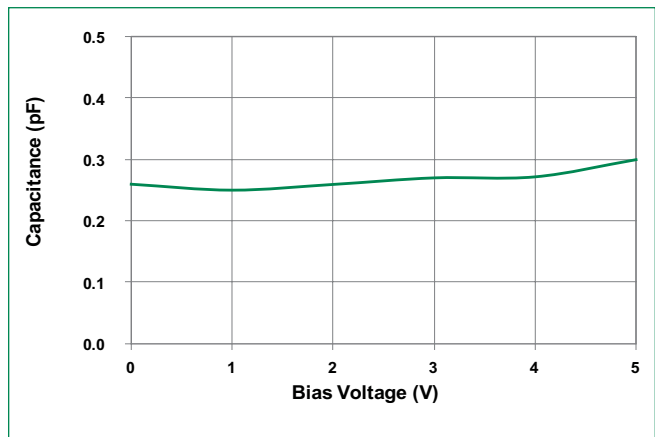

Positive Transmission Line Pulsing (TLP) Plot

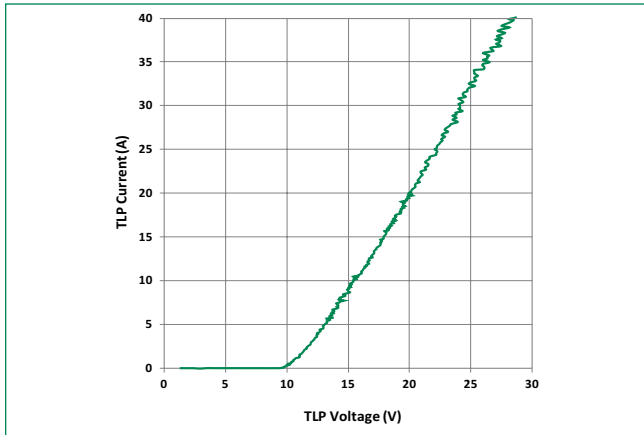

Negative Transmission Line Pulsing (TLP) Plot

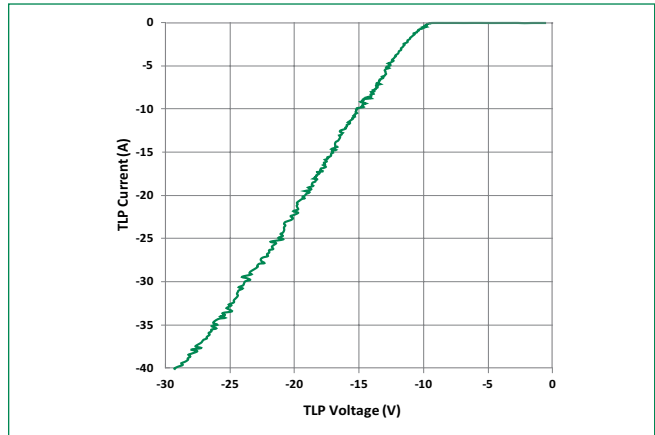

Soldering Parameters

Reflow Condition		Pb - Free assembly
Pre Heat	- Temperature Min ($T_{s(min)}$)	150°C
	- Temperature Max ($T_{s(max)}$)	200°C
	- Time (min to max) (t_s)	60 - 180 secs
Average ramp up rate (Liquidus) Temp (T_L) to peak		3°C/second max
$T_{s(max)}$ to T_L - Ramp-up Rate		3°C/second max
Reflow	- Temperature (T_L) (Liquidus)	217°C
	- Temperature (t_l)	60 - 150 seconds
Peak Temperature (T_p)		260 ^{+0/-5} °C
Time within 5°C of actual peak Temperature (t_p)		20 - 40 seconds
Ramp-down Rate		6°C/second max
Time 25°C to peak Temperature (T_p)		8 minutes Max.
Do not exceed		260°C

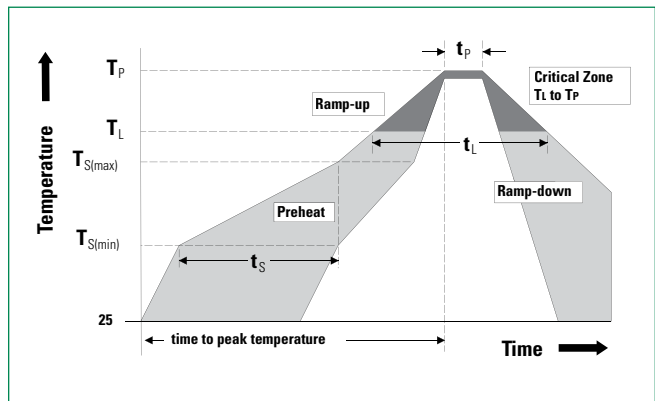

Product Characteristics of 01005 Flipchip

Lead Plating	Sn
Lead Material	Copper
Lead Coplanarity	6µm(max)
Substrate material	Silicon
Body Material	Silicon

Notes :

1. All dimensions are in millimeters
2. Dimensions include solder plating.
3. Dimensions are exclusive of mold flash & metal burr.

Ordering Information

Part Number	Package	Marking	Min. Order Qty.	Packaging Option	P0/P1	Packaging Specification
SP3042-01WTG	01005 Flipchip	+	15000	Tape & Reel - 8mm tape/7" reel	4mm/2mm	EIA RS-481

Part Numbering System

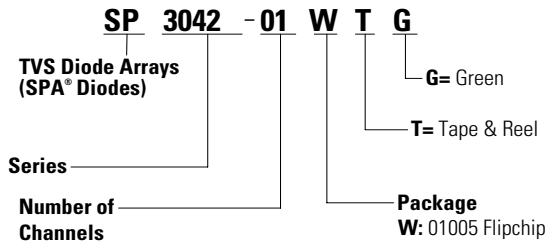

Part Marking System

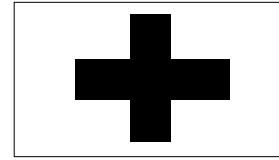

Package Dimensions — 01005 Flipchip

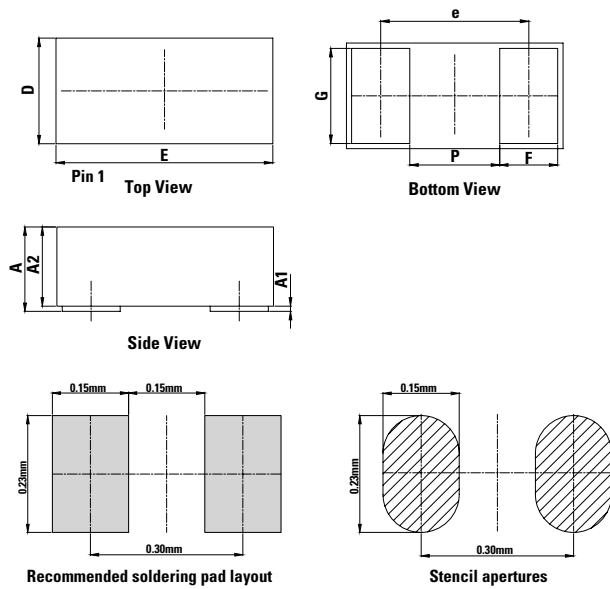

Symbol	01005 Flipchip					
	Millimeters			Inches		
	Min	Typ	Max	Min	Typ	Max
A	0.168	0.181	0.194	0.0066	0.0071	0.0076
A1	0.008	0.011	0.014	0.0003	0.0004	0.0006
A2	0.160	0.170	0.180	0.0063	0.0067	0.0071
e	0.280 BSC			0.011 BSC		
D	0.200	0.230	0.260	0.0079	0.0091	0.0102
E	0.400	0.430	0.460	0.0157	0.0169	0.0181
F	0.110	0.130	0.150	0.0043	0.0051	0.0059
G	0.180	0.200	0.220	0.0071	0.0079	0.0087
P	0.130	0.150	0.170	0.0051	0.0059	0.0067

Embossed Carrier Tape & Reel Specification — 01005 Flipchip

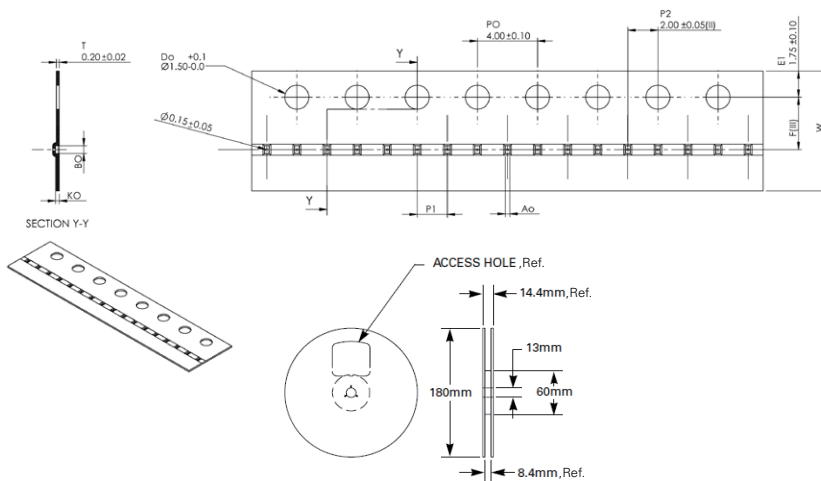

Symbol	Millimeters
A0	0.30+/-0.03
B0	0.51+/-0.03
K0	0.20 + 0.03
F	3.50 +/- 0.05
P1	2.00+/-0.10
W	8.00+/-0.10

Disclaimer Notice - Information furnished is believed to be accurate and reliable. However, users should independently evaluate the suitability of and test each product selected for their own applications. Littelfuse products are not designed for, and may not be used in, all applications. Read complete Disclaimer Notice at: www.littelfuse.com/disclaimer-electronics

© 2020 Littelfuse, Inc.
Specifications are subject to change without notice.
Revised: 06/17/20

单击下面可查看定价，库存，交付和生命周期等信息

[>>Littelfuse\(美国力特\)](#)