

承认书
APPROVAL SHEET

厂商：丽智电子（昆山）有限公司 客户：_____

Supplier:

customer:

核准 Approved by	审核 Checked by	制作 Prepared by

核准 Approved by	审核 Checked by	制作 Prepared by

地址：江苏省昆山市汉浦路 989 号

Address: No. 989, Hanpu Road Kunshan City Jiangsu Province

Tel:0086-0512-57780531

Fax:0086-0512-57789581

汽车厚膜晶片电阻承认书-AQ 系列

Approval Specification for Automotive Thick Film Chip Resistors - Type **AQ**

1. 范围 (scope) :

1.1 适用于本公司所生产的无铅、汽车厚膜晶片电阻 AQ 系列

This specification applies to Automotive thick film chip resistors which meet requirements of Pb free.

1.2 本公司的无铅产品指的晶片电阻端电极无铅，而存在于电阻层的玻璃中的符合 RoHS 豁免条款。

There no lead exists in terminal of resistor, and lead which exist in glass of resistor layer meets RoHS exemption.

1.3 符合 AEC-Q200 條款

The relevant provisions of the AEC-Q200

2. 产品料号 (part number) :

0603 1/10W 5% 100 Ω

AQ0603JA0101G

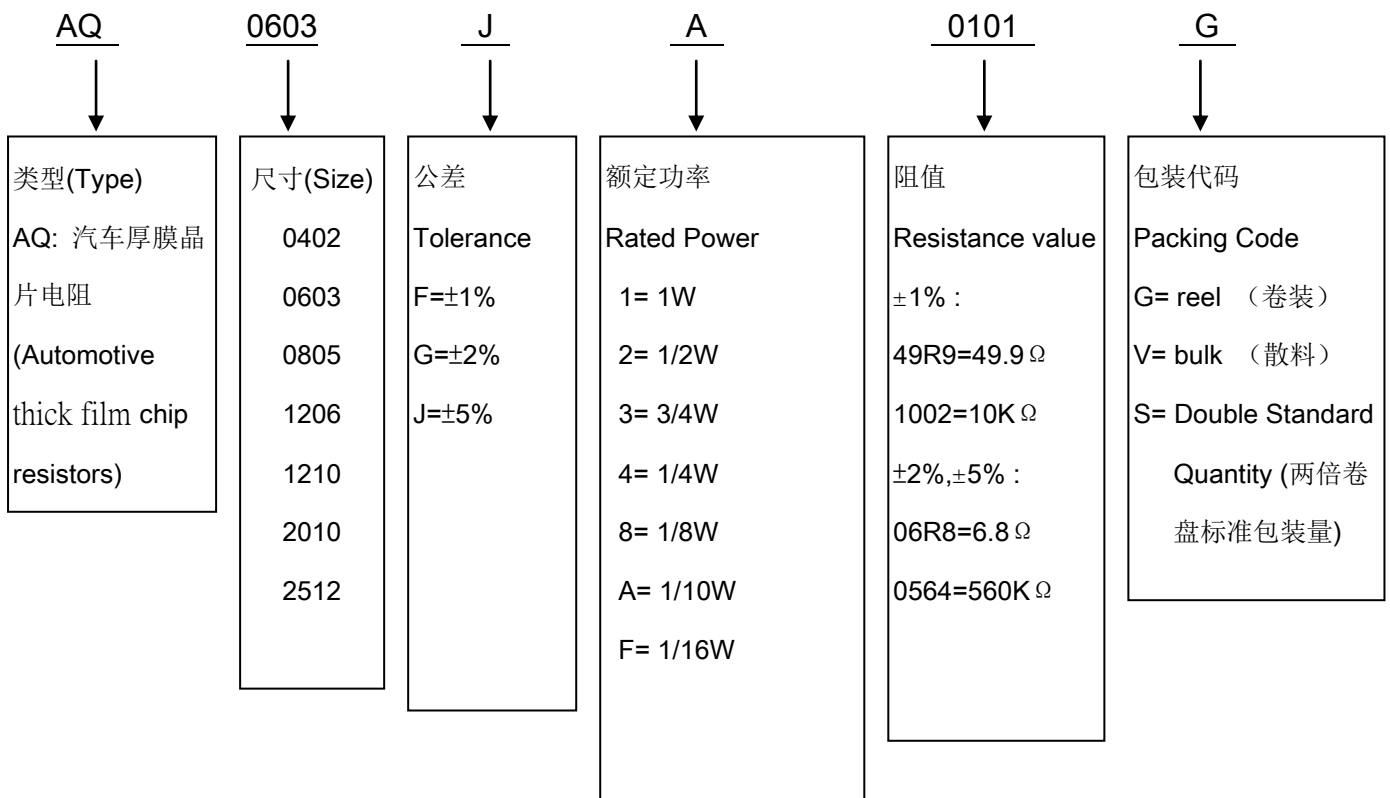

汽车厚膜晶片电阻承认书-AQ 系列

Approval Specification for Automotive Thick Film Chip Resistors - Type **AQ**

3. 电阻本体字码标示 (Marking on the Resistor's Body):

<p>※AQ0402 因本体太小，本体上无字码标示 For AQ0402 size, no marking on the body due to the small size of the resistor</p> <p>※ 公差±5%的产品，以三字码标示，前两位表示阻值的有效数字，最后一位表示 10 的乘幂 ±5% tolerance product: the marking is 3 digits, the first 2 digits are significant figures of resistance value and the 3rd one denotes the power number of 10, (10^x)</p> <p>※ ±1%的产品，以四字码标示，前三位表示阻值的有效数字，最后一位表示 10 的乘幂 ±1% tolerance product: the marking is 4 digits, the first 3 digits are significant figures of resistance value and the 4th one denotes the power number of 10, (10^x)</p> <p>※ AQ0603 ±1% E96 系列的标准阻值，因电阻本体太小，采用三位代码标示。 Standard E96 series values of AQ0603 ±1%: due to the small size of the resistor's body, use 3digits code to indicate the resistance value.</p>		<p>472=47×10²=4.7K Ω</p> <hr/> <p>10Ω 以下标示：5R6=5.6Ω Below 10Ω: 5R6=5.6Ω</p> <hr/> <p>4992=499×10²=49.9K Ω</p> <hr/> <p>100Ω 以下标示：6R81=6.81Ω Below 100Ω: 6R81=6.81Ω</p>
--	---	--

AQ0603 ±1% E96 系列的标准阻值代码(Standard E96 Series Resistance Value Code for 0603 ±1% Marking)

代码 Code	阻值 Value	代码 Code	阻值 Value	代码 Code	阻值 Value	代码 Code	阻值 Value	代码 Code	阻值 Value	代码 Code	阻值 Value
1	100	17	147	33	215	49	316	65	464	81	681
2	102	18	150	34	221	50	324	66	475	82	698
3	105	19	154	35	226	51	332	67	487	83	715
4	107	20	158	36	223	52	340	68	499	84	732
5	110	21	162	37	237	53	348	69	511	85	750
6	113	22	165	38	243	54	357	70	523	86	768
7	115	23	169	39	249	55	365	71	536	87	787
8	118	24	174	40	255	56	374	72	549	88	806
9	121	25	178	41	261	57	383	73	562	89	825
10	124	26	182	42	267	58	392	74	576	90	845
11	127	27	187	43	274	59	402	75	590	91	866
12	130	28	191	44	280	60	412	76	604	92	887
13	133	29	196	45	287	61	422	77	619	93	909
14	137	30	200	46	294	62	432	78	634	94	931
15	140	31	205	47	301	63	442	79	649	95	953
16	143	32	210	48	309	64	453	80	665	96	976

Approval Specification for Automotive Thick Film Chip Resistors - Type **AQ**

AQ0603 ±1% E96 系列的指数代码(Multiplier Code for AQ0603 ±1% Marking)

代码 Code	Y	X	A	B	C	D	E	F
指数 Multiplier	10^{-2}	10^{-1}	10^0	10^1	10^2	10^3	10^4	10^5

阻值标示如下(So the resistance value are marked as the following examples)



$10D=124 \times 10^3=124K \Omega$



$38Y=243 \times 10^2=2.43 \Omega$

AQ0603 ±1%的产品，在标准 E24 系列中，但不属于 E96 系列，标示与 5%的字码相同，但是在字码下加一条线
 Standard E24 and not belong to E96 series values of AQ0603 ±1%, the marking is the same as 5% tolerance but marking as underline



$\underline{331}=33 \times 10^1=330 \Omega$



$\underline{560}=56 \times 10^0=56 \Omega$

4. 尺寸 (dimension) :

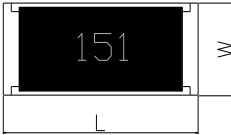
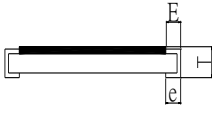
尺寸 dimension					
	单位 (unit) : mm				
型别 (Type)	L	W	T	E	e
AQ0402	1.00±0.05	0.50±0.05	0.30±0.05	0.15±0.10	0.20±0.10
AQ0603	1.60±0.10	0.80±0.10	0.45±0.10	0.25±0.20	0.30±0.20
AQ0805	2.00±0.15	1.25±0.15	0.50±0.10	0.35±0.20	0.40±0.20
AQ1206	3.10±0.15	1.60±0.15	0.55±0.10	0.45±0.25	0.40±0.25
AQ1210	3.10±0.15	2.50±0.15	0.55±0.15	0.35±0.25	0.60±0.25
AQ2010	5.00±0.20	2.50±0.20	0.55±0.15	0.65±0.25	0.50±0.25
AQ2512	6.25±0.20	3.10±0.20	0.55±0.15	0.85±0.25	0.95±0.25

5. 功率衰减曲线 (Derating Curve) :

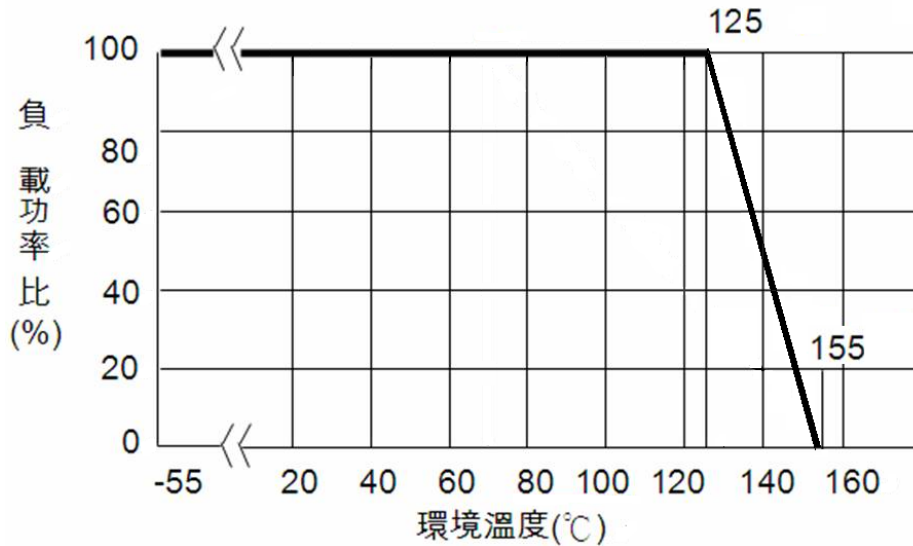

工作温度范围 (Operating Temperature Range) : $-55^{\circ}\text{C} \sim +155^{\circ}\text{C}$;

储存条件 (storage condition) : $5 \sim 30^{\circ}\text{C}$, $30 \sim 75\% \text{RH}$.

6. 电阻结构 (Construction) :

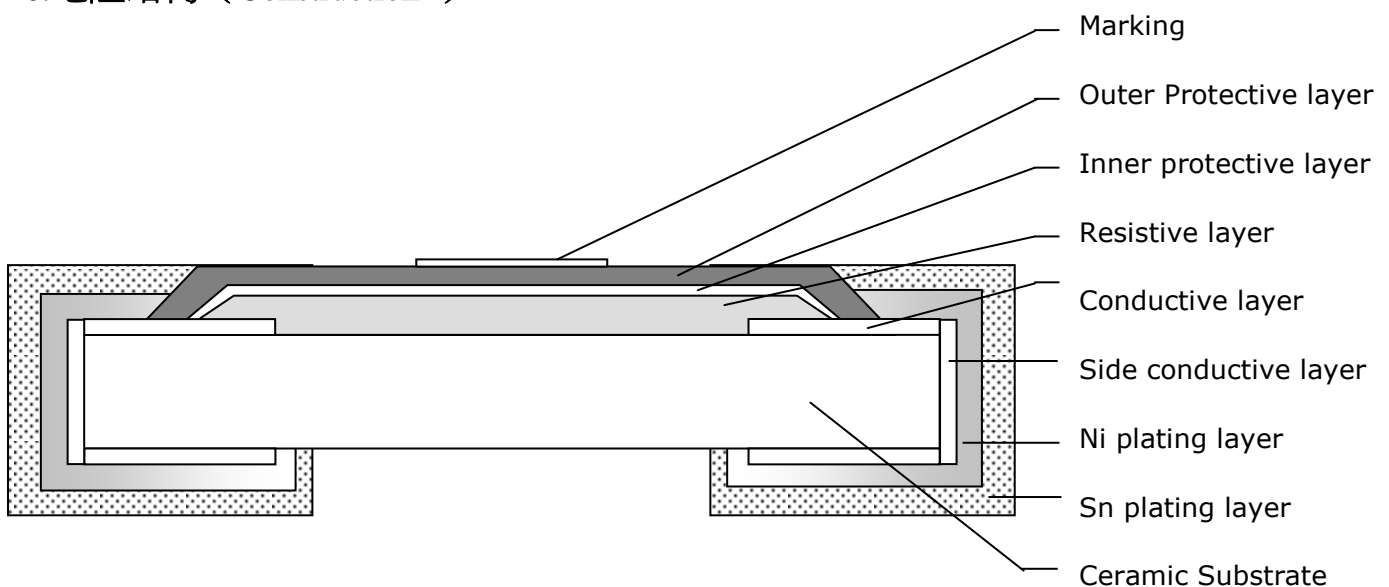

汽车厚膜晶片电阻承认书-AQ 系列

Approval Specification for Automotive Thick Film Chip Resistors - Type **AQ**

No.	结构 construction	主要材料 Major material
1	陶瓷基板 Ceramic substrate	三氧化二铝 Al ₂ O ₃
2	银电极 Conductive layer	银钯 AgPd
3	侧电极 Side conductive layer	镍铬合金 NiCr
4	阻体层 Resistive layer	氧化钌+玻璃 RuO ₂ + glass
5	内保护层 Inner protective layer	玻璃 Glass
6	外保护层 Outer Protective layer	环氧树脂 Epoxy
7	文字 Marking	环氧树脂 Epoxy
8	镍电极 Ni plating layer	镍 Ni
9	锡电极 Sn plating layer	雾锡 Matte Tin

7. 阻值范围 (resistance range) :

型别 Type	阻值范围 Resistance Range		
	1%	2%	5%
AQ0402	1Ω~10MΩ, jumper	1Ω~10MΩ, jumper	1Ω~10MΩ, jumper
AQ0603	1Ω~10MΩ, jumper	1Ω~10MΩ, jumper	1Ω~10MΩ, jumper
AQ0805	1Ω~10MΩ, jumper	1Ω~10MΩ, jumper	1Ω~10MΩ, jumper
AQ1206	1Ω~10MΩ, jumper	1Ω~10MΩ, jumper	1Ω~10MΩ, jumper
AQ1210	1Ω~10MΩ, jumper	1Ω~10MΩ, jumper	1Ω~10MΩ, jumper
AQ2010	1Ω~10MΩ, jumper	1Ω~10MΩ, jumper	1Ω~10MΩ, jumper
AQ2512	1Ω~10MΩ, jumper	1Ω~10MΩ, jumper	1Ω~10MΩ, jumper

8. 电气特性 (electrical characteristics) :

型别 Type	AQ0402	AQ0603	AQ0805	AQ1206	AQ1210	AQ2010	AQ2512
额定功率 Rated power	1/16W	1/10W	1/8W	1/4W	1/2W	3/4W	1W
最大工作电压 Max Working Voltage	50V	50V	150V	200V	200V	200V	200V
最大过负荷电压 Max Overload Voltage	100V	100V	300V	400V	400V	400V	400V
绝缘耐压 Dielectric Withstanding Voltage	100V	100V	300V	500V	500V	500V	500V
零欧姆阻值 Resistance Value of Jumper	<50mΩ	<50mΩ	<50mΩ	<50mΩ	<50mΩ	<50mΩ	<50mΩ
零欧姆额定电流 Rated Current of Jumper	1A	1A	1.5A	1.9A	2.2A	3A	3A
零欧姆电阻最大电流 Max Current of Jumper	2A	2A	3.5A	5A	5.5A	7.5A	7.5A

备注 (remark) :

※ 额定电压计算公式 (The rated voltage is calculated by the following formula) :

$$E = \sqrt{RP}$$

E : 额定电压 (Rated Voltage) (V)

P : 额定功率 (Rated Power) (W)

R : 电阻阻值 (Resistance) (ohm)

※ 如果计算出的电压超过此型别的最大工作电压, 则此型别的最大工作电压为此电阻的额定电压。
 In case the value calculated by the formula exceed the maximum working voltage as above table 8, the maximum working voltage shall be regarded as rated voltage.

9. 性能(Performance Specifications)

内容 Item	规格 Specification Limits	测试方法 Test Methods
温度系数 Temperature Coefficient	1Ω~10Ω产品 (Product) : -250~+500PPM/°C ±2%&±5%产品 (Product) : ±200 PPM/°C ±1%产品 (Product) : ±100 PPM/°C	JIS C5201 4.8
焊锡性 Solderability	最少 95%面积上锡(Min 95% coverage)	J-STD-002
绝缘电阻 Insulation resistance	>10GΩ	JIS C5201 4.6
绝缘耐压 Dielectric withstanding voltage	无击穿、飞弧及可见机械性损伤 No evidence of flashover, mechanical damage arcing or insulation breakdown	JIS C5201 4.7
短时间过负荷 Short-time overload	±(1.0% +0.05 Ω) Max (最大)	JIS C5201 4.13
端子弯曲 Board Flex	±(1.0% +0.05 Ω) Max (最大)	AEC-Q200-005
抗焊锡热 Resistance to soldering heat	±(1.0% +0.05 Ω) Max (最大)	MIL-STD-202 METHOD 210
负荷寿命 Operational life	±(2.0% +0.05 Ω) Max (最大)	MIL-STD-202 METHOD 108
耐湿特性 Biased Humidity	±(2.0% +0.05 Ω) Max (最大)	MIL-STD-202 METHOD 103
温度循环 Temperature cycling	±(1.0% +0.05 Ω) Max (最大)	JESD22 METHOD JA-104
温湿循环 Moisture resistance	±(2.0% +0.05 Ω) Max (最大)	MIL-STD-202 METHOD 106
温湿度敏感等级 Moisture sensitive level	Level 1	J-STD-020
高温储存 High Temperature Exposure(Storage)	±(1.0% +0.05 Ω) Max (最大)	MIL-STD-202 METHOD 108
ESD 试验 ESD test	±(3.0% +0.05 Ω) Max (最大)	AEC-Q200-002

Approval Specification for Automotive Thick Film Chip Resistors - Type AQ
10. 包装规格 (Tapping Specification)
10.1 卷盘尺寸 (reel dimension)

尺寸 Dimensions		A	B	C	F	W
AQ0402 AQ0603 AQ0805 AQ1206 AQ1210	mm	178±2.0	60.0±1.0	13.5±0.5	11.4±0.1	9.00±0.3
	Inch	7.008±0.079	2.362±0.039	0.531±0.020	0.449±0.039	0.354±0.012
AQ2010 AQ2512	mm	178±2.0	60.0±1.0	13.5±0.5	15.4±1.0	13.0±0.3
	Inch	7.008±0.079	2.362±0.039	0.531±0.020	0.606±0.039	0.512±0.012

※ 备注 (Remark) : (1)0402 每卷 10,000 pcs

0402 Quantity per Reel 10,000 pcs/Reel

(2) 2010/2512 每卷 4,000 pcs

2010/2512 Quantity per Reel 4,000 pcs/Reel

(3) 0603/0805/1206/1210 每卷 5,000pcs

0603/0805/1206/1210 Quantity per Reel 5,000 pcs/Reel

(4) 0402 可依客户要求每卷 20,000pcs

0402 Quantity per Reel 20,000 pcs/Reel as customer requirement

Reel

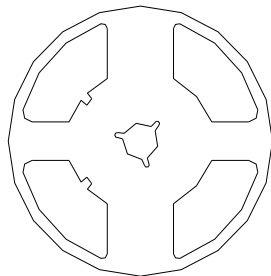

Standard Quantity per Reel
5,000 pcs/Reel

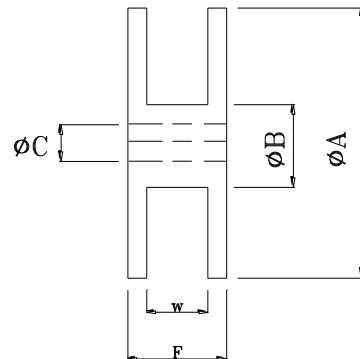

Approval Specification for Automotive Thick Film Chip Resistors - Type **AQ**

10.2 包装尺寸 (packing dimension)

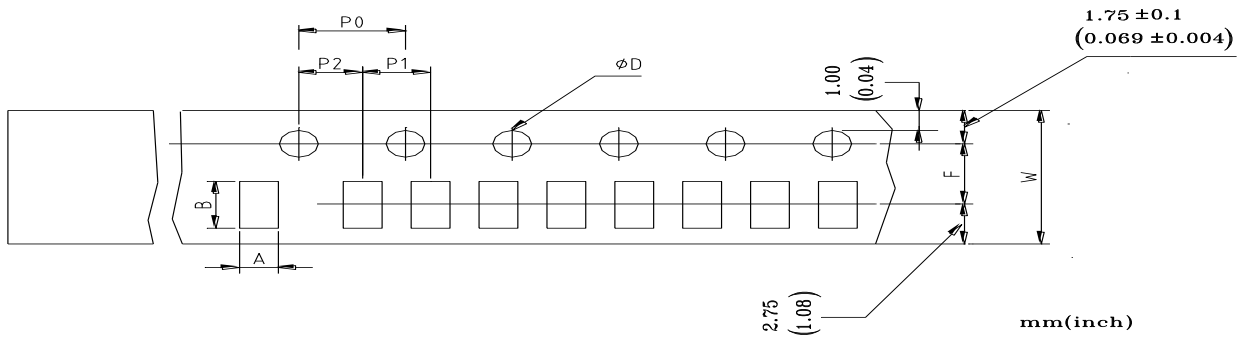

Unit: mm

尺寸 Dimensions	A	B	D	F	P0	P1	P2	W
AQ0402	0.65±0.10	1.15±0.10	1.50± ^{0.1} / _{0.0}	3.50±0.05	4.00±0.10	2.00±0.10	2.00±0.05	8.00±0.20
AQ0603	1.10±0.10	1.90±0.10	1.50± ^{0.1} / _{0.0}	3.50±0.05	4.00±0.10	4.00±0.10	2.00±0.05	8.00±0.20
AQ0805	1.65±0.20	2.40±0.20	1.50± ^{0.1} / _{0.0}	3.50±0.05	4.00±0.10	4.00±0.10	2.00±0.05	8.00±0.20
AQ1206	1.90±0.20	3.50±0.20	1.50± ^{0.1} / _{0.0}	3.50±0.05	4.00±0.10	4.00±0.10	2.00±0.05	8.00±0.20
AQ1210	2.80±0.20	3.50±0.20	1.50± ^{0.1} / _{0.0}	3.50±0.05	4.00±0.10	4.00±0.10	2.00±0.05	8.00±0.20
AQ2010	2.90±0.10	5.30±0.10	1.50± ^{0.1} / _{0.0}	5.50±0.05	4.00±0.10	4.00±0.10	2.00±0.05	12.0±0.10
AQ2512	3.40±0.10	6.60±0.10	1.50± ^{0.1} / _{0.0}	5.50±0.05	4.00±0.10	4.00±0.10	2.00±0.05	12.0±0.10

11. 信赖性测试 (Reliability Test Methods)

内容 Item	测试条件 Test Conditions
温度系数 Temperature Coefficient	$TCR = \frac{(R - R_0)}{(t - t_0)} R_0 \times 10^6 \text{ (ppm)}$ <p> R_0 电阻在室温下的阻值(resistance at room temperature) R 电阻在 125°C 或 -55°C 下的阻值(resistance at 125°C or -55°C) t_0 室温(room temperature) t 测试温度 (test temperature 125°C or -55°C) </p>
焊锡性 Solderability	<p>For both Leaded & SMD. Electrical test not required. Magnification 50X. Conditions: Leaded: Method A@235°C, category 3. SMD: a) Method B, 4 hrs @ 155°C dry heat @ 235°C. b) Method B @ 215°C category 3. c) Method D category 3 @ 260°C. 用于引脚型和表面贴装型元件, 不需要电气测试. 放大倍数 50 倍。 测试条件: 引脚型: 方法 A@215°C, 类别 3. 表面贴装型: a) 方法 B, 4 小时@155°C 干热@235°C. b) 方法 B@215°C 类别 3. c) 方法 D 类别 3@260°C.</p>
绝缘电阻 Insulation resistance	<p>电阻本体上加载最大的工作电压 60 秒后, 测量绝缘阻抗 Applied the maximum DC working voltage on the center of body for 60±5seconds. Then measure insulation resistance</p>
绝缘耐压 Dielectric withstanding voltage	<p>电阻本体上加载最大的工作电压 60 秒。 Applied the maximum DC working voltage on the center of body for 60±5seconds.</p>
短时间过负荷 Short-time overload	<p>加载 2.5 倍的额定电压, 时间 5 秒后测量试验前后的阻值变化率。 Applied 2.5 times of rated voltage for 5 second. Measure the variation of resistance.</p> $\Delta R\% = \frac{R_2 - R_1}{R_1} * 100 \text{----- (\%)}$ <p> R_1 = 试验前阻值(resistance before test) R_2 = 试验后阻值(resistance after test) </p>
端子弯曲 Board Flex	<p>持续时间最少 60 秒。 60 sec minimum holding time</p>

汽车厚膜晶片电阻承认书-AQ 系列

Approval Specification for Automotive Thick Film Chip Resistors - Type **AQ**

内容 Item	测试条件 Test Conditions
抗焊锡热 Resistance to soldering heat	<p>锡炉温度 260±5℃,时间 10±0.5 秒,样品不进行预热。注意:单一波峰焊-表面贴装元件按程序 2:引脚产品按程序 1 进行焊接,浸入器件本体的 1.5mm 的深度. Soldering bath at 260±5℃ for 10±0.5sec. No pre-heat of samples. Note: Single Wave Solder-Procedure 2 for SMD and Procedure 1 for Leaded with solder within 1.5mm of device body.</p> $\Delta R\% = \frac{R_2 - R_1}{R_1} * 100 \text{-----} (\%)$ <p>R1 = 试验前阻值(resistance before test) R2 = 试验后阻值(resistance after test)</p>
负荷寿命 Operational life	<p>条件 D,恒定温度 125℃,加载额定功率,试验结束 24±4 小时后进行测试. Condition D Steady State TA=125℃ at rated power. Measurement at 24±4 hours after test conclusion.</p> $\Delta R\% = \frac{R_2 - R_1}{R_1} * 100 \text{-----} (\%)$ <p>R1 = 试验前阻值(resistance before test) R2 = 试验后阻值(resistance after test)</p>
耐湿特性 Biased Humidity	<p>加载 10%额定功率, 85℃/85%RH, 持续通电 1000H,试验结束 24±4 小时后进行测试 1000 hours 85℃/85%RH. Note: Specified conditions: 10% of operating power. Measurement at 24±4 hours after test conclusion.</p> $\Delta R\% = \frac{R_2 - R_1}{R_1} * 100 \text{-----} (\%)$ <p>R1 = 试验前阻值(resistance before test) R2 = 试验后阻值(resistance after test)</p>

汽车厚膜晶片电阻承认书-AQ 系列

Approval Specification for Automotive Thick Film Chip Resistors - Type **AQ**

温度循环 Temperature cycling	<p>-55℃~+ 125℃, 循环 1000 次, 在每一个极限温度持续时间不超过 30 分钟, 且温度转换时间不超过 1 分钟, 试验结束 24±4 小时后进行测试.</p> <p>1000 Cycles (-55℃ to +125℃) Measurement at 24±4 hours after test conclusion. 30min maximum dwell time at each temperature extreme. 1min. maximum transition time.</p> $\Delta R\% = \frac{R_2 - R_1}{R_1} * 100 \text{-----} (\%)$ <p>R1 = 试验前阻值(resistance before test) R2 = 试验后阻值(resistance after test)</p>
温湿循环 Moisture resistance	<p>25℃~65℃,90~100%RH, 2.5小时; 65℃ 90~100%RH, 3小时; 65℃~25℃,80~100%RH,2.5小时,10个循环,试验结束24±4小时后进行测试.</p> <p>25℃~65℃,90~100%RH, 2.5H; 65℃ 90~100%RH, 3H; 65℃~25℃ 80~100%RH, 2.5H, 10 cycles, Measurement at 24±4 hours after test conclusion.</p> $\Delta R\% = \frac{R_2 - R_1}{R_1} * 100 \text{-----} (\%)$ <p>R1 = 试验前阻值(resistance before test) R2 = 试验后阻值(resistance after test)</p>
温湿度敏感等级 Moisture sensitive level	<p>电阻放入恒温恒湿箱, 温度 85℃, 湿度 90~95 %RH;时间 168 小时, 再进行回流焊测试</p> <p>Put the specimen in a chamber at 85℃ temperature and 85% relative humidity for 168H, then apply reflow test</p>
高温储存 High Temperature Exposure(Storage)	<p>125℃ 下放置 1000h, 不加载功率, 试验结束 24±4 小时后进行测试.</p> <p>1000 hrs. @ T=125℃. Unpowered. Measurement at 24±4 hours after test conclusion</p> $\Delta R\% = \frac{R_2 - R_1}{R_1} * 100 \text{-----} (\%)$ <p>R1 = 试验前阻值(resistance before test) R2 = 试验后阻值(resistance after test)</p>
ESD 试验 ESD test	<p>加载规定静电电压2次/间隔1秒, 0402规格:0.5KV, 0603规格:1KV, 其它规格2KV.</p> <p>0402: 0.5KV, 0603: 1.0KV, Other:2KV, 2times/1s</p>

12. 上胶带剥离力测试 (Peel force of top cover tape)

上胶带以 200mm/分钟的速度，沿 165~180 度角的方向进行剥离，如下图所示。纸带的剥离力范围为 10g~70g；载带的剥离力范围为 30~100g

The top cover tape is pulled at a speed of 200 mm/min with the angle between the tape during peel and the direction of unreeling maintained at 165 to 180 degree as following picture. The peel force of paper carrier tape shall be 0.1N to 0.7N(10 to 70 g), the peel force of plastic carrier tape shall be 0.3N to 1N (30 to 100 g)

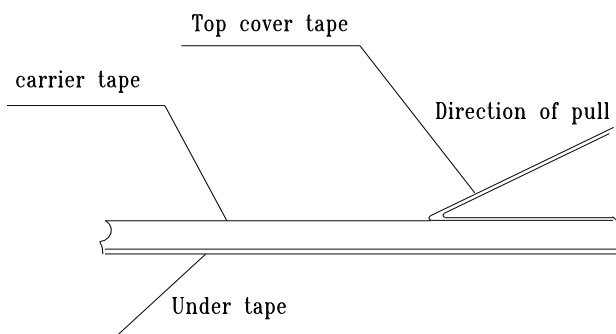

13. 焊接 (soldering)

13.1 建议回流焊曲线 (Recommend reflow soldering profile)

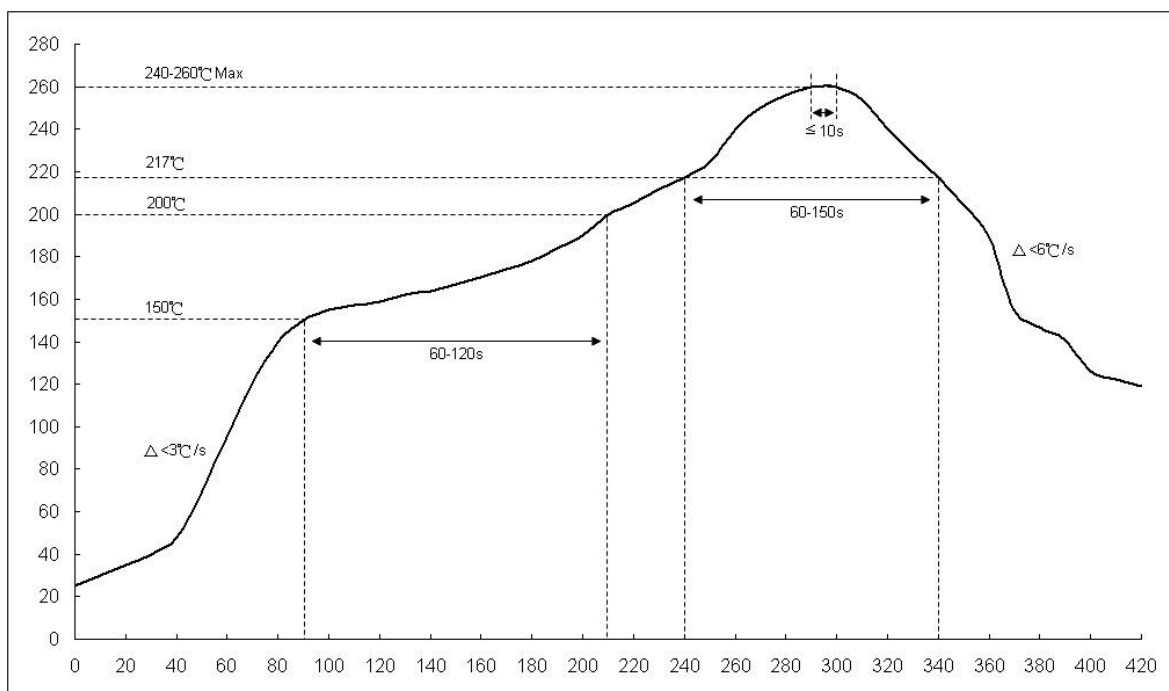

13.2 建议波峰焊曲线 (Recommend wave soldering profile)

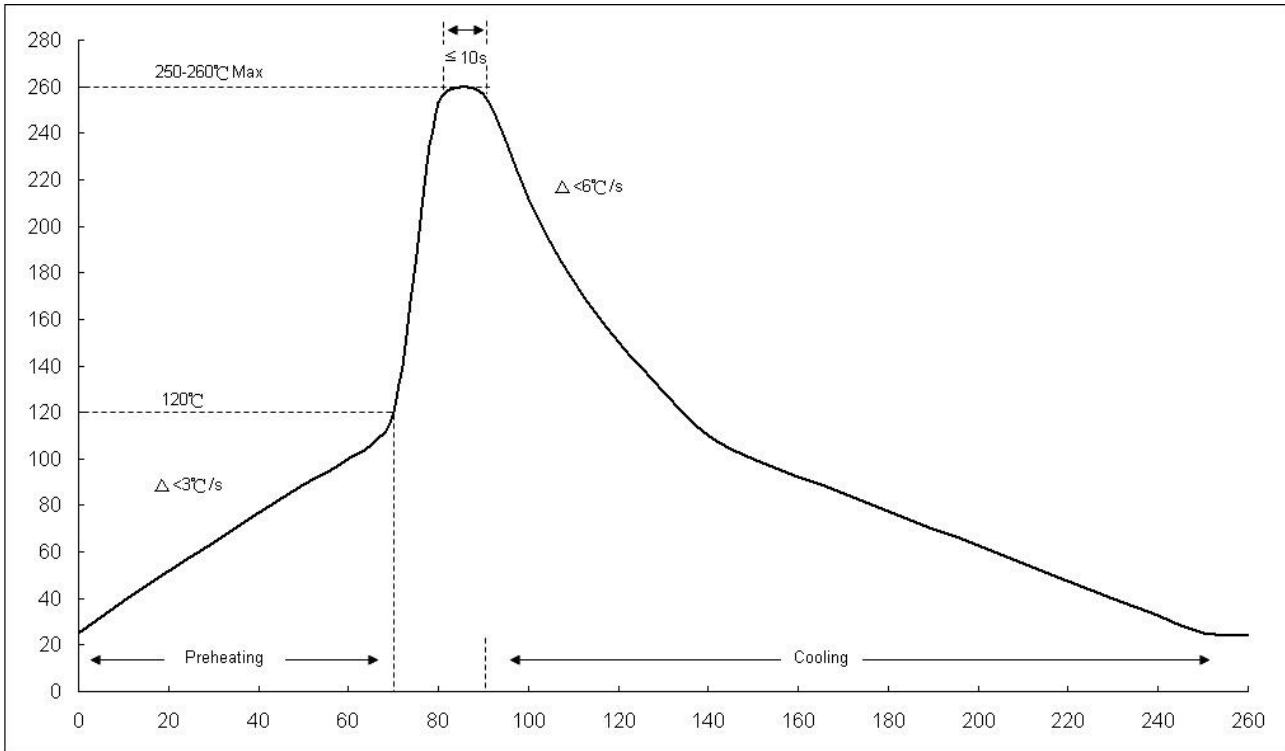

13.3 手工焊温度 (hand soldering temperature)

烙鐵溫度 $350 \pm 10^\circ\text{C}$ 3 秒之內，避免烙鐵接觸電阻本體

The iron temperature is $350 \pm 10^\circ\text{C}$, hand soldering time less than 3S. Avoid solder iron tip direct touch the components body

单击下面可查看定价，库存，交付和生命周期等信息

[>>LIZ\(丽智\)](#)