



1A Buck/Boost Charge Pump LED Driver

General Description

The LP3367 buck/boost charge pump LED driver is designed for powering high brightness white LEDs for camera flash applications. The LP3367 automatically switches modes between step-up and step-down ensuring that LED current does not depend on the forward voltage. The LP3367 provides two current levels for TORCH and FLASH modes. In TOUCH mode, The LED current sense reference voltage is 50mV. The LED current can be determined by current sense resistor. In FLASH mode, the current sense reference voltage can be adjusted by external resistor. The maximum LED current can be set up to 1A. The LP3367 is available in a 10-lead 3mm*3mm TDFN-10 package and is rated over the -40°C to 85°C temperature range.

Order Information

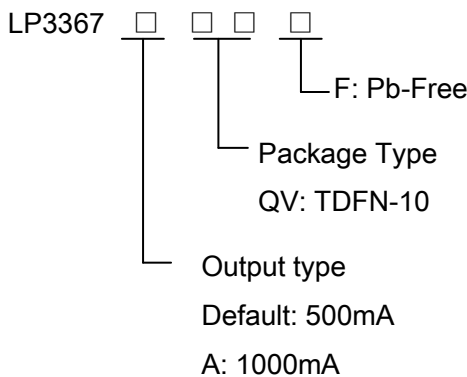

Features

- ◆ Input Voltage Range: 2.7V to 5.5V
- ◆ Adjustable FLASH Mode Current
- ◆ Output Current up to 1A
- ◆ Up to 95% Efficiency in TORCH Mode
- ◆ Automatic Buck/Boost Mode Switchover
- ◆ Minimum External Components: No Inductors
- ◆ <1uA Quiescent Current
- ◆ 2 MHz High Frequency Operation
- ◆ 50mV Reference for Low Loss Sensing
- ◆ PWM Dimming Control
- ◆ Automatic Soft Start Limits Inrush Current
- ◆ Over-Voltage Protection
- ◆ Over-Current protection
- ◆ Thermal Fault Protection
- ◆ Low Ripple and EMI
- ◆ Ultra-Low Dropout Voltage in Buck Mode
- ◆ 1.6 Second Timeout in FLASH Mode
- ◆ 3mm×3mm TDFN-10 Package
- ◆ RohS Compliant and 100% Lead (Pb)-Free

Applications

- ✧ WLED Backlight driver
- ✧ OLED Backlight driver
- ✧ PDA
- ✧ MID/PTV

Marking information

Device	Marking	Package	Shipping
LP3367	LPS LP3367 XXXX	TDFN-10	3K/REEL
Y: Year code. W: Weeks code. X: Series number code.			



Functional Pin Description

Package Type	Pin Configurations
TDFN-10	<p>The diagram shows a top-down view of the TDFN-10 package. The pins are numbered 1 through 10. On the left side, pins 1, 2, 3, 4, and 5 are labeled VIN, C1, C2, FLASH, and EN respectively. On the right side, pins 10, 9, 8, 7, and 6 are labeled VOUT, PGND, SGND, FB, and RSET respectively. A dashed pink line outlines the package footprint.</p>

Pin Description

Pin	Name	Description
1	VIN	Input voltage for the charge pump, Decouple with 1uF ceramic capacitor close to the pins of the IC.
2	C1	Positive input for the external flying capacitor. Connect a ceramic 1uF capacitor close to the pins of the IC.
3	C2	Negative input for the external flying capacitor. Connect a ceramic 1uF capacitor close to the pins of the IC.
4	FLASH	Logic input to toggle operation between FLASH and TORCH mode. In TORCH mode FB is regulated to the internal 50mV reference. In FLASH mode FB reference voltage can be adjusted by changing the resistor from RSET pin to ground. Choose the external current sense resistor (RSENSE) based on desired current in TORCH mode and FLASH mode.
5	EN	Shutdown control Input. Connect to VIN for normal operation, connect to ground for shutdown.
6	RSET	Connect a resistor from this pin to ground, When in FLASH mode (FLASH = High) this resistor sets the current regulation point according to the following: $V_{FB} = (1.26V / RSET) \times 11.2k\Omega$
7	FB	Feedback input for the current control loop. Connect directly to the current sense resistor.
8	SGND	Internal ground pin. Control circuitry returns current to this pin.
9	PGND	Power ground pin. Flying capacitor current returns through this pin.
10	VOUT	Charge pump output voltage. Decouple with an external capacitor. At least 1uF is recommended. If Higher value capacitor is used output ripple is smaller.



Typical Application Circuit

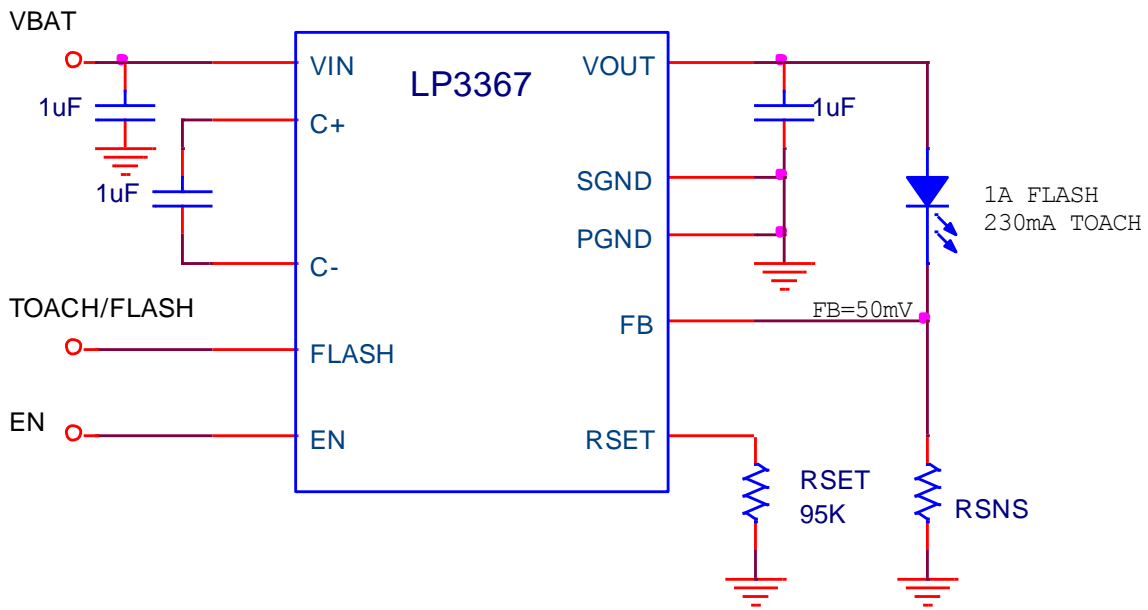

Function Block Diagram

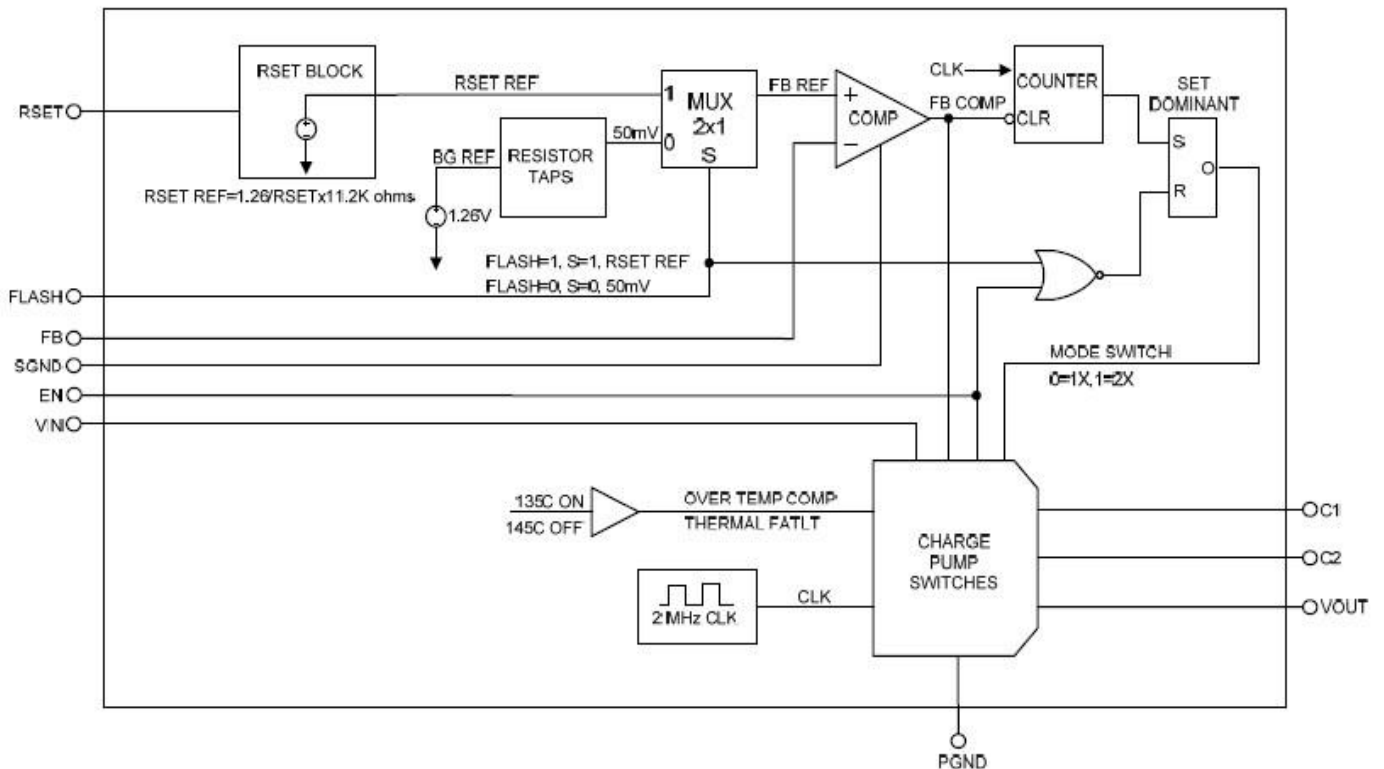



Absolute Maximum Ratings

✧ Input Voltage to GND -----	0.3V to +6V
✧ Other Pin to GND -----	0.3V to +6V
✧ Output Current Pulse(Flash) -----	1200mA
✧ Output Current Continuous(Torch) -----	400mA
✧ Operating Junction Temperature Range (TJ) -----	150°C
✧ Maximum Soldering Temperature (at leads, 10sec) -----	260°C
✧ Storage Temperature Range -----	-65°C to 165°C
✧ Operation Ambient Temperature Range -----	-20°C to 85°C
✧ QFN 4x4-16 Thermal Resistance (θ_{JA}) -----	65°C/W
✧ QFN 4x4-16 Power Dissipation at TA=25°C (PDmax) -----	1.5W





Electrical Characteristics

(VIN = VEN = 3.6V, CIN = CFC = COUT = 1uF, Typical values are TA=25°C)

Symbol	Parameter	Conditions	Min.	Typ.	Max.	Unit
VIN	Input Voltage		2.7		5.5	V
RCH1	Charge Pump Equivalent Resistance (2×mode)	VIN = 3.6V, VFB = 0V		5		Ω
RCH2	Charge Pump Equivalent Resistance (1×mode)	VIN = 3.6V		0.4	0.7	Ω
IQ	Quiescent Current	VIN=2.7V-5.5V, FLASH = GND, 1×mode, ILOAD = 100uA		0.48	3	mA
		FLASH = High, 2×mode		2	3.5	
ISHDN	Shutdown Current	EN = GND, VIN = 5.5V			1	μA
VFB	FB Reference Voltage	FLASH = GND	45	50	55	mV
		FLASH = High, RSET = 95kΩ	138	150	162	
	FB Reference Voltage Range	FLASH = High, Guaranteed by design	100		400	mV
IFB	FB Current	VFB = 0.3V			0.5	uA
FOSC	Oscillator Frequency			2		MHz
VOH	EN,FLASH Logic Low				0.4	V
VOL	EN,FLASH Logic High		1.3			V
IEN	EN,FLASH Pin Current				0.5	uA
TOUT	VOUT Turn-On Time	VIN = 3.6V, FB within 90% of regulation		250	500	us
TFLASH_ON	Maximum Flash on time	FLASH = High		1.6		s
TSD	Thermal Shutdown Temperature			145		°C



Typical Operating Characteristics

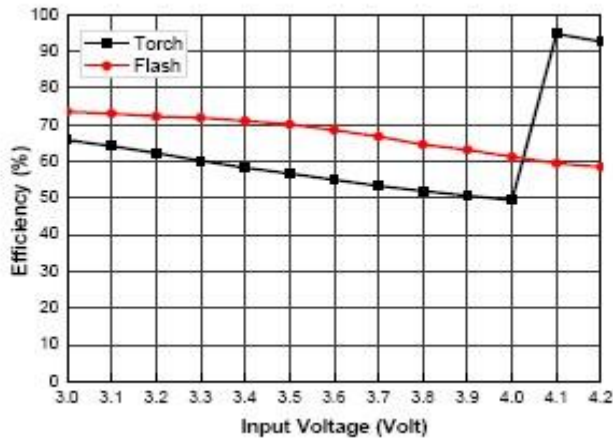

Efficiency vs. Input Voltage
(200mA Torch, 300mA Flash, $V_F=4V$)

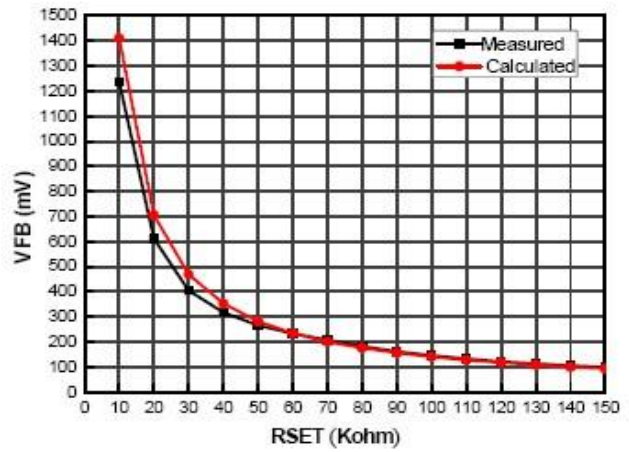

V_{FB} vs. RSET

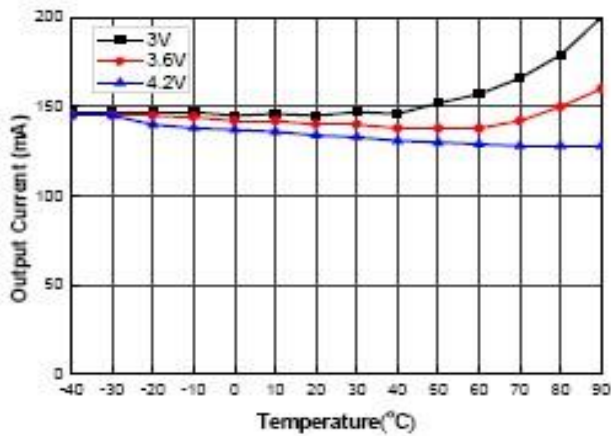

Toach Mode Output Current vs. Temperature
($C_{IN}=C_{FC}=C_{OUT}=1\mu F$)

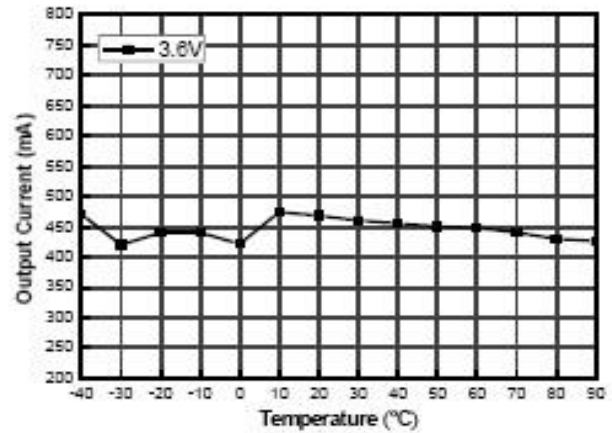

Flash Mode Output Current vs. Temperature
($C_{IN}=C_{FC}=C_{OUT}=1\mu F$)

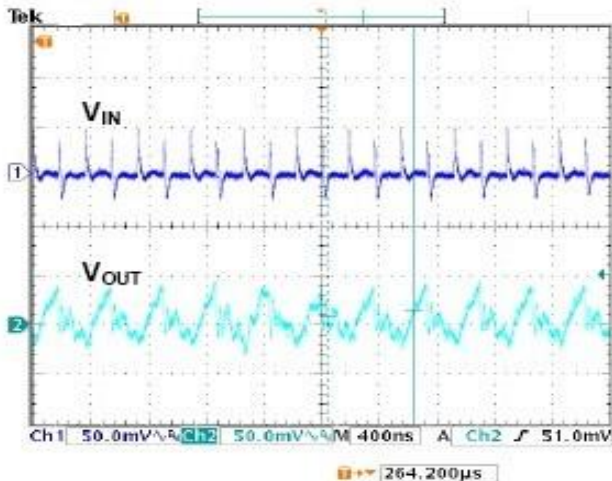

Ripple 2X Torch 150mA, $V_{IN}=3V$

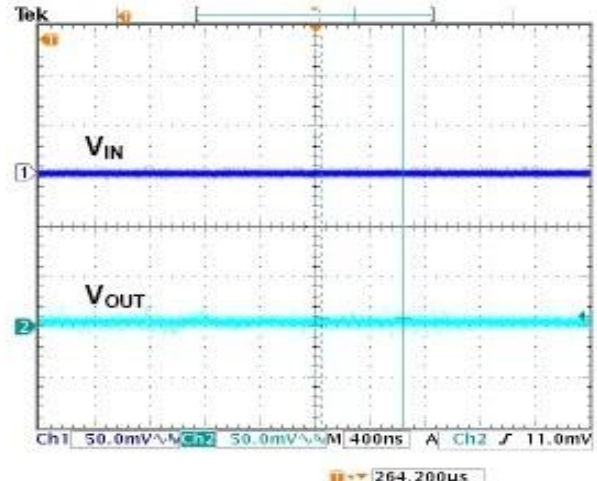

Ripple 1X Torch 150mA, $V_{IN}=3.6V$

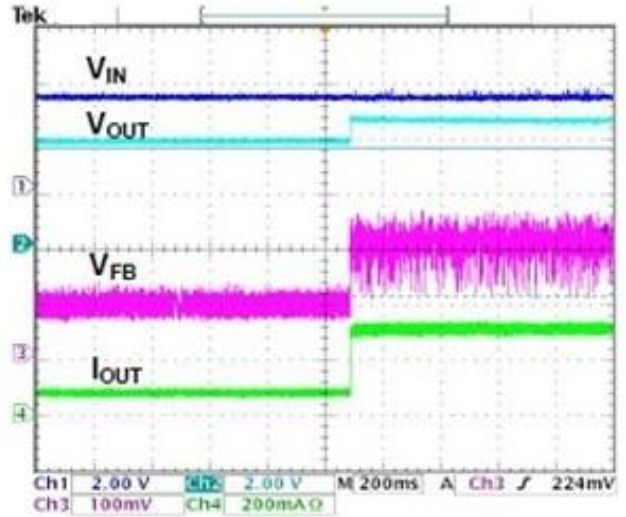
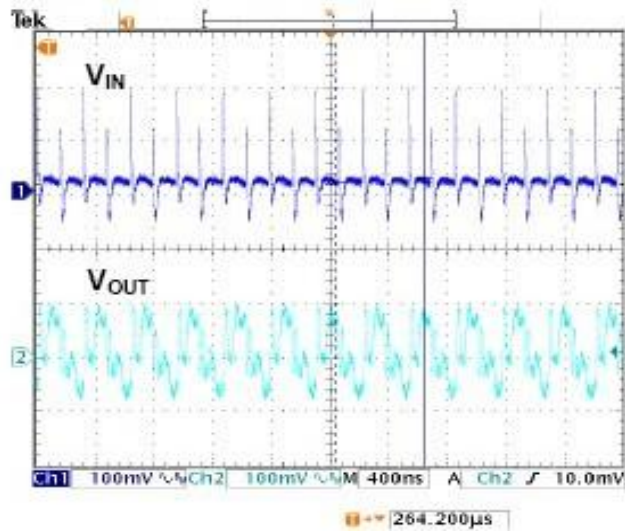
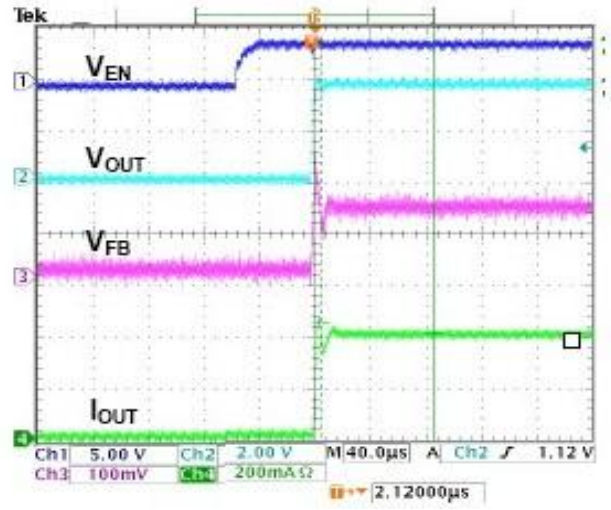
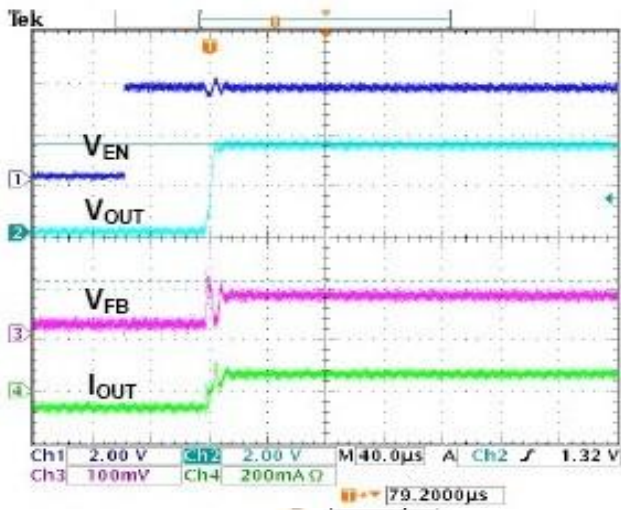



Function Description

The LP3367 Buck/Boost charge pump is designed for converting a Li-Ion battery voltage of 2.7V to 4.2V to drive a white LED used in digital still camera Flash and Torch applications. The LP3367 has two modes (Torch and Flash). Torch mode can be used continuously at a lower output current than Flash and is often used for several seconds in a digital still camera “movie” mode. Flash mode is usually used with a pulse of about 200 to 300 milliseconds to generate a high intensity Flash.

The LP3367 also has two modes of operation to control the output current. The 1x mode and 2x mode. Operation begins after the enable pin EN receives a logic high, then LP3367 starts in the 1x mode, which acts like a linear regulator to control the output current by continuously monitoring the feedback pin FB. In 1x mode, if the LP3367 auto detects a dropout condition, which is when the FB pin is below the regulation point for more than 32 cycles of the internal clock, the LP3367 automatically switches to the 2x mode. The LP3367 remains in the 2x mode until one of four things happens: 1.the enable pin EN has been toggled, 2.the Flash pin has changed from high to low. 3.Vin is cycled or, 4.a thermal fault occurs.

The 2x mode is the charge pump mode where the output can be pumped as high as two times the input voltage, provided the output does not exceed the maximum voltage for the LP3367, which is internally limited to about 5.5V. In the 2x mode, as in the 1x mode, the output current is regulated by the voltage at the FB pin.

In the TORCH mode (FLASH=GND), the FLASH pin is set to logic low and the LP3367 FB pin regulates to 50mV output:

$$V_{FB}=50\text{mV (Touch mode)}$$

In the FLASH mode, (FLASH=VIN), the FB regulation voltage is set by the external resistor (RSET) connected between the RSET pin and SGND and the equation:

$$V_{FB}=1.26\times 11.2\text{k}\Omega/\text{RSET} , \text{ (Flash mode)}$$

Where 1.26V is the internal band gap reference voltage and 11.2kΩ is an internal resistance used to scale the RSET current. Typical values of RSET are 40kΩ to 180kΩ for a range of VFB=300mV to 75mV in Flash mode.

The output current is then set in either Flash or Torch mode by the equation:

$$I_{OUT}= V_{FB}/R_{SENSE}$$

Flash Timeout Protection

Due to the high currents typically available in Flash mode, it is necessary to protect the white LED from damage if left on too long. The LP3367 has a timeout in Flash mode of approximately 1.6 seconds after which it will shut down operation. Operation will not begin again in Flash mode until the EN pin or FLASH pin have been set Low and then High again.

Over-Voltage Protection

The Over-Voltage Protection monitors the output voltage. When the output voltage rises above 5.5V, the Over-Voltage Protection shuts off all of the output switches to prevent the output voltage from rising further. When the output decreases below 5.5V, the device resumes normal operation.



Over-Current Protection

The Over-Current Protection circuitry monitors the average current out of the FB pin. If the average current exceeds the two times set current, then the over current protection circuitry shuts off the output switches to protect the chip.

Brightness Control Using PWM

Dimming control can be achieved by applying a PWM control signal to the EN pin. The brightness of the white LEDs is controlled by increasing and decreasing the duty cycle of the PWM signal. While the operating frequency range of the PWM control is from 60Hz to 700Hz, the recommended maximum brightness frequency range of the PWM signal is from 60Hz to 200Hz. A repetition rate of at least 60Hz is required to prevent flicker.



Application Information

The LP3367 charge pump circuit requires 3 capacitors: 1 μ F input, 1 μ F output and 1 μ F fly capacitors are typically recommended. For the input capacitor, a value of 10 μ F will help reduce input voltage ripple for applications sensitive to ripple on the battery voltage. All the capacitors should be surface mount for low lead inductance necessary at the 2MHz switching frequency of the LP3367 and to obtain low ESR, which improves bypassing on the input and output and improves output voltage drive by reducing output resistance. The input and output capacitors should be located as close to the VIN and VOUT pins as possible to obtain best bypassing, and the returns should be connected directly to the PGND pin or to the thermal pad ground located under the LP3367. The fly capacitor should be located as close to the C1 and C2 pins as possible.



Packaging Information

TDFN-10

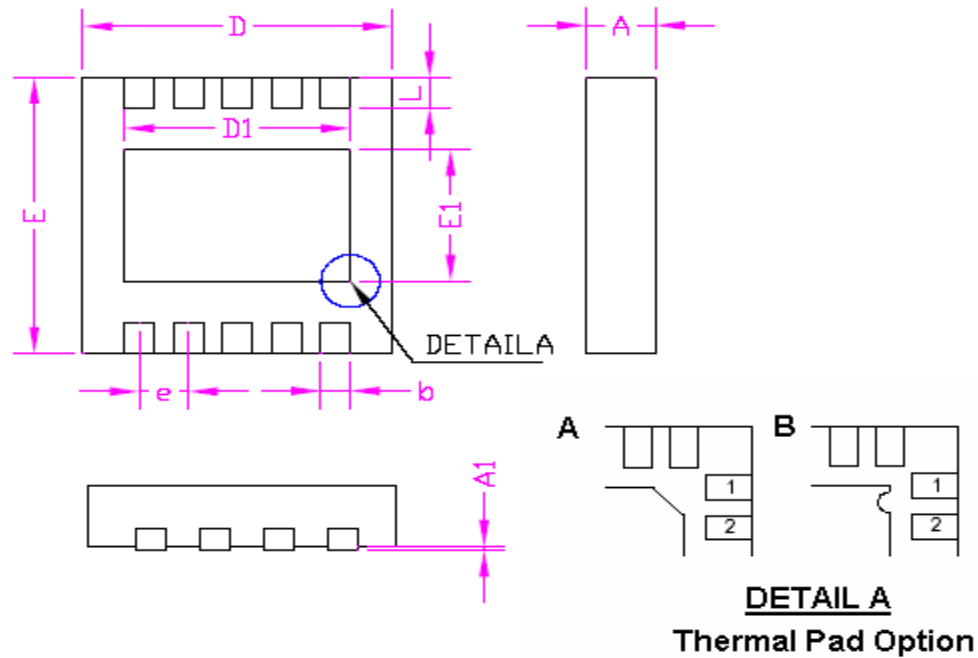

SYMBOLS	MILLIMETERS		INCHES	
	MIN.	MAX.	MIN.	MAX.
A	0.70	0.80	0.028	0.031
A1	0.00	0.05	0.000	0.002
D1	2.50		0.098	
D	2.90	3.10	0.114	0.122
E1	1.70		0.067	
E	2.90	3.10	0.114	0.122
L	0.30	0.50	0.012	0.020
b	0.18	0.30	0.007	0.012
e	0.50		0.020	
D1	2.40		0.094	

单击下面可查看定价，库存，交付和生命周期等信息

[>>LOW POWER\(微源半导体\)](#)