



Features

- 2.4V to 6V input voltage range
- Low on-state resistance to 70mΩ
- 30μA low current consumption
- Ultra-low shutdown current (<100nA)
- Fixed or adjustable current limit
 - Fixed: 0.65A, 1.35A, 1.6A, 2.3A
 - Adjustable: 200mA to 2.5A
- Under-voltage lockout
- Blocking reverse current
- Thermal shutdown protection
- Fast current limit response
- ESD Protection:
 - Human Body Model: 4kV
 - Charged Device Model: 0.5kV
- SOT23-5 Package
- UL Approved File No. E526435

Applications

- Notebook and PC
- Cell phone and PDAs
- USB or other peripheral ports
- Camera

General Description

The LPW5202 is a series of load switches which provide full protection to systems and loads which may encounter large current conditions.

The device contains a 70mΩ current-limited P-channel MOSFET which can operate over an input voltage range from 2.4V to 6V. The current limit is fixed or could be settable using an external resistor. When the current reaches the threshold, the device will limit the current to constant value to prohibit excessive currents from causing damage. Internally, current is prevented from flowing when the MOSFET is off and the output voltage is higher than the input voltage. Switch is controlled by an active-high logic pin. Thermal shutdown protection is integrated which shuts off the switch to prevent damage to the part when a continuous over-current condition causes excessive heating.

The device part LPW5202SDB5F11, LPW5202FDB5F11, LPW5202FB5F21 and LPW5202FDB5F21 have certified by UL/CUL62368-1 2nd.

These parts are available in a space-saving 5 pin SOT23 package.



SOT23-5

Ordering and Package Information

Device	Marking	Current Limiting (typ)	Output Discharge	Flag indicator	Package	Shipping
LPW5202AB5F		Adjustable	No	No	SOT23-5	3K/REEL
LPW5202ADB5F	LPS D0YWX	Adjustable	Yes	No	SOT23-5	3K/REEL
LPW5202FB5F21	LPS 1WYWX	2.3A	No	Yes	SOT23-5	3K/REEL
LPW5202FDB5F21	LPS D3YWX	2.3A	Yes	Yes	SOT23-5	3K/REEL
LPW5202FB5F15		1.6A	No	Yes	SOT23-5	3K/REEL
LPW5202FDB5F15		1.6A	Yes	Yes	SOT23-5	3K/REEL
LPW5202FB5F11		1.35A	No	Yes	SOT23-5	3K/REEL
LPW5202FDB5F11	LPS D2YWX	1.35A	Yes	Yes	SOT23-5	3K/REEL
LPW5202FB5F06		0.7A	No	Yes	SOT23-5	3K/REEL
LPW5202FDB5F06	LPS D1YWX	0.7A	Yes	Yes	SOT23-5	3K/REEL
LPW5202SB5F21		2.3A	No	No	SOT23-5	3K/REEL



LPW5202SDB5F21		2.3A	Yes	No	SOT23-5	3K/REEL
LPW5202SB5F15		1.6A	No	No	SOT23-5	3K/REEL
LPW5202SDB5F15		1.6A	Yes	No	SOT23-5	3K/REEL
LPW5202SB5F11		1.35A	No	No	SOT23-5	3K/REEL
LPW5202SDB5F11	LPS D5YWX	1.35A	Yes	No	SOT23-5	3K/REEL
LPW5202SB5F06		0.7A	No	No	SOT23-5	3K/REEL
LPW5202SDB5F06		0.7A	Yes	No	SOT23-5	3K/REEL

Marking indication:

Y: Production Year, W: Production Week, X: Series Number



Typical Application Circuitry

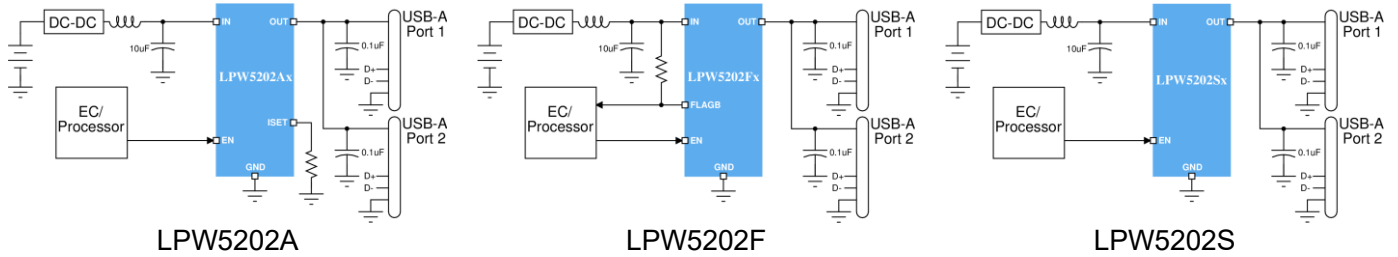
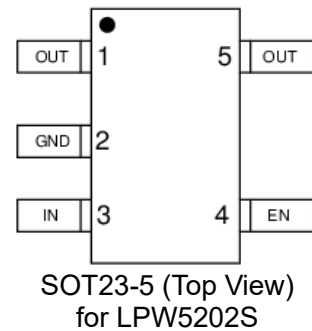
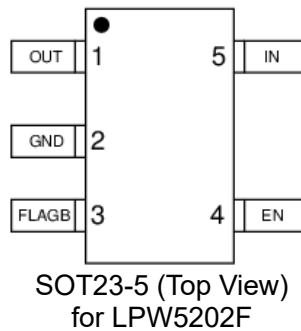
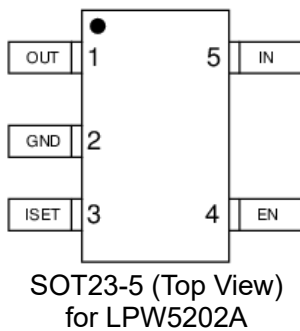

Figure 1. Typical Application Circuitry

Pin Configuration



Pin Description

Pin	Description
GND	Ground
IN	Power supply and input of power switch
OUT	Output of power switch
ISET	Current limit setting pin to connect a resistor to ground
FLAGB	Open-drain active-low flag pin to indicate fault condition
EN	Active-high device enable pin



Functional Block Diagram

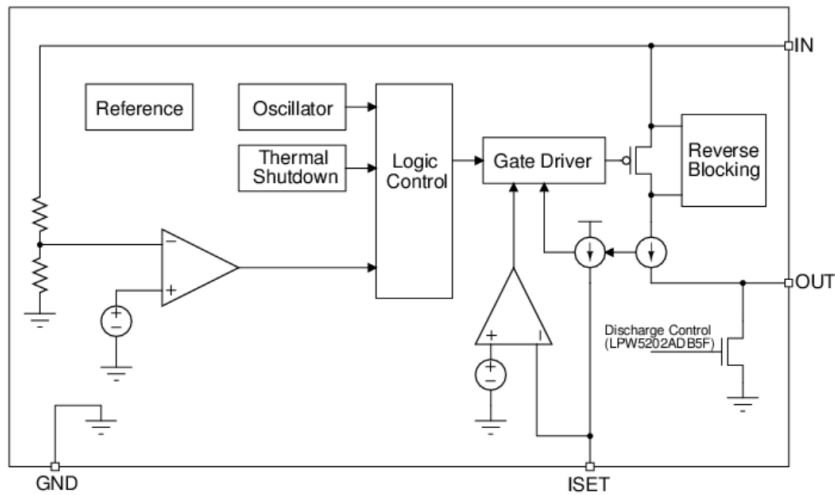

Figure 2. Internal Block Diagram (LPW5202A)

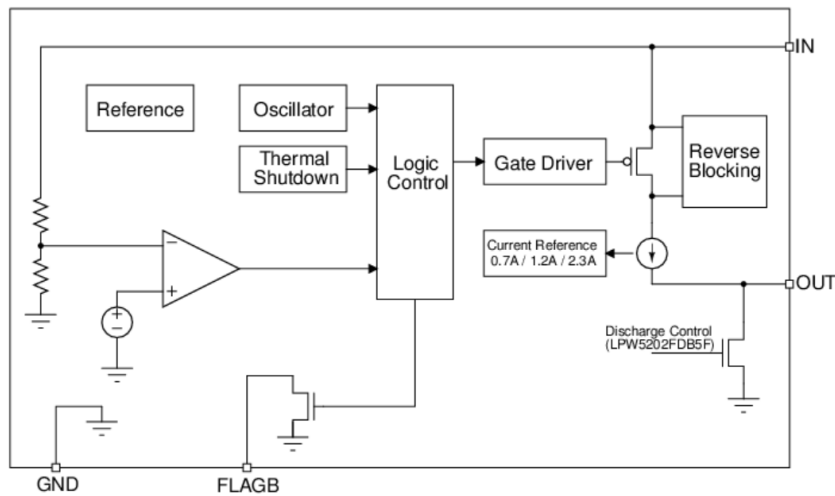

Figure 3. Internal Block Diagram (LPW5202F)

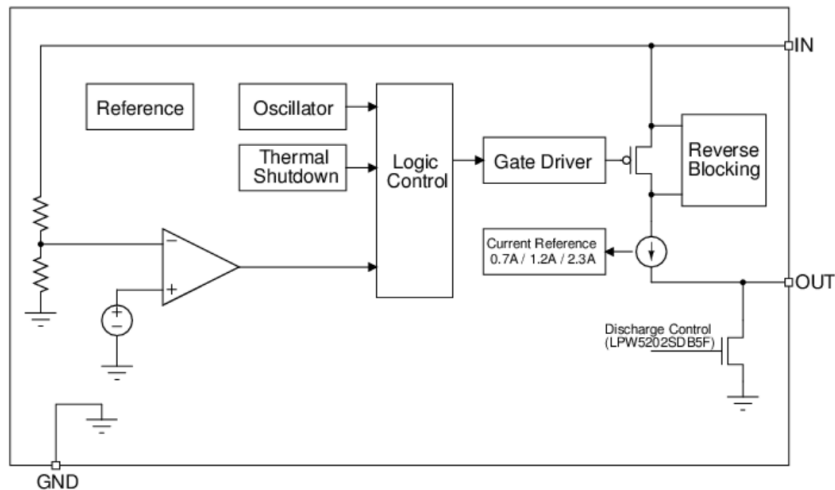

Figure 4. Internal Block Diagram (LPW5202S)



Absolute Maximum Ratings (Note 1)

- IN to GND ----- -0.3V to 7V
- OUT to GND ----- -0.3V to 7V
- EN to GND ----- -0.3V to 7V
- ISET to GND ----- -0.3V to 7V
- FLAGB to GND ----- -0.3V to 7V
- Maximum Junction Temperature (T_A) ----- +150°C
- Storage Temperature Range ----- -65°C to +150°C
- Maximum Soldering Temperature (at leads, 10 seconds) ----- +260°C

Note 1: Stresses beyond those listed under "Absolute Maximum Ratings" may cause permanent damage to the device. These are stress ratings only, instead of functional operation of the device at these or any other conditions beyond those indicated in the operational sections of the specifications. Exposure to absolute maximum rating conditions for extended periods may affect device reliability.

Thermal Information

- Maximum Power Dissipation (P_D, T_A ≤ 25°C) ----- 0.6W
- Thermal Resistance (From junction to ambient, θ_{JA}) (Note 2) ----- 203°C/W
- Thermal Resistance (From junction to case, θ_{JC}) (Note 2) ----- 120°C/W

Note 2: It is based on 2S2P JEDEC standard PCB.

ESD Ratings

- HBM (Human Body Model, JEDEC JS-001) ----- ±4000V
- CDM (Charged Device Model, JEDEC JS-002) ----- ±500V

Recommended Operating Conditions

- Input Voltage ----- 2.4V to 6.0V
- Enable Voltage ----- 0V to 6V
- Limited current setting ----- 200mA to 2.5A
- Ambient Temperature ----- -40°C to 85°C

Electrical Characteristics

The following parameters are guaranteed under condition V_{IN} = 5V, T_A = -40°C to 85°C unless otherwise noted, T_A = 25°C for typical value.

Parameters	Symbol	Test conditions	Min	Typ	Max	Unit
On-resistance	R _{DS(ON)}	V _{IN} = 5V, I _{OUT} = 200mA, T _A = 25°C		70	100	mΩ
Input quiescent current	I _Q	V _{IN} = 5V, OUT floating, V _{EN} = 5V		30	50	μA
Input shutdown current	I _{SD}	V _{IN} = 5V, OUT grounded, V _{EN} = 0V			200	nA
Under voltage lockout level	V _{UVLO_F}	IN voltage falling	2.25	2.5	2.75	V
	V _{UVLO_R}	IN voltage rising	2.4	2.65	2.9	V



Parameters		Symbol	Test conditions	Min	Typ	Max	Unit
Current limit level	LPW5202Axxx	I _{LIM}	Refer to Figure 14 and Equation (1)				A
	LPW5202xxx21		V _{IN} = 5V, V _{OUT} = 4.5V, T _A =25°C	2.10	2.30	2.50	
	LPW5202xxx15		V _{IN} = 5V, V _{OUT} = 4.5V, T _A =25°C	1.4	1.6	1.8	
	LPW5202xxx11		V _{IN} = 5V, V _{OUT} = 4.5V, T _A =25°C	1.20	1.35	1.50	
	LPW5202xxx06		V _{IN} = 5V, V _{OUT} = 4.5V, T _A =25°C	0.55	0.65	0.75	
Current limit level accuracy ⁽³⁾ ⁽⁴⁾ (LPW5202Axxx)		ACC _{LIM}	V _{IN} = 5V, 500mA < I _{LIM} < 2.5A		10		%
			V _{IN} = 5V, 200mA < I _{LIM} < 500mA		15		
Short circuit protection level ⁽⁴⁾		I _{SHORT}	V _{IN} = 5V, T _A =25°C		4.5	6.5	A
Output auto discharge		R _{DIS}	V _{IN} = 5V, V _{EN} = 0V	90	110	130	Ω
Reverse voltage protection ⁽³⁾		V _{RVP}	V _{IN} = 5V, V _{OUT} - V _{IN} level to trigger off		115	150	mV
Enable logic high voltage level		V _{IH}	V _{IN} = 2.4V to 6V	1.4			V
Enable logic low voltage level		V _{IL}	V _{IN} = 2.4V to 6V			0.4	V
Leakage current on EN pin		I _{LKG_EN}	V _{EN} = V _{IN} = 5V		3.5		μA
Output logic low voltage level		V _{OL}	V _{IN} = 2.4V to 6V, I _{FLAGB} = 10mA			0.1	V
Leakage on FLAGB pin		I _{LKG_FLAGB}	V _{IN} = 5V, V _{FLAGB} = 5V			0.1	μA
FLAGB de-bounce time		t _{DEB_FLAGB}	V _{IN} = 5V, R _{FLAG_PU} = 10kΩ, T _A = 25°C, time from I _{OUT} hits I _{OCP} to V _{FLAGB} = 0.1V		10		ms
OCP response time ⁽³⁾		t _{OCP}	V _{IN} = 5V, T _A = 25°C, time from I _{OUT} hits I _{OCP} to I _{OUT} stop rising	3	7	15	μs
Short circuit protection time ⁽³⁾		t _{SHORT}	V _{IN} = 5V, T _A = 25°C, time from I _{OUT} hits I _{SHORT} to switch turned off		300		ns
Load switch turned on delay ⁽³⁾		t _{DON}	V _{IN} = 5V, R _{OUT} = 10Ω, C _{OUT} = 1μF, time from enabled to V _{OUT} = 0.5		500		μs
Output rising time ⁽³⁾		t _R	V _{IN} = 5V, R _{OUT} = 10Ω, C _{OUT} = 1μF, time from V _{OUT} = 0.1 × V _{IN} to 0.9 × V _{IN}		600		μs
Load switch turned off delay ⁽³⁾		t _{OFF}	V _{IN} = 5V, R _{OUT} = 10Ω, C _{OUT} = 1μF, time from disabled to V _{OUT} = 0.9 × V _{IN}		1.2		μs
Output discharge time ⁽³⁾		t _{DIS}	V _{IN} = 5V, R _{OUT} = 10Ω, C _{OUT} = 1μF, time from V _{OUT} = 0.9 × V _{IN} to 0.1 × V _{IN}		25		μs
Thermal shutdown trigger		T _{SD}	Temperature rising		150		°C
Thermal shutdown release		T _{SD_REL}	Temperature falling		130		°C

Note 3. The parameter does not include the variation from external resistor on ISET.

Note 4. The parameter is guaranteed by design and characterization.



Typical Timing Diagram

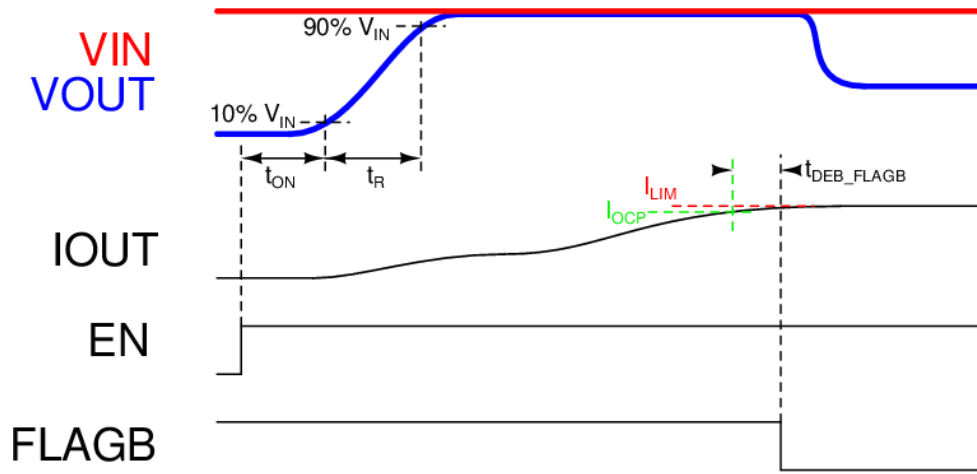

Figure 5. Start-up and over current protection

Typical Characteristics and Diagrams

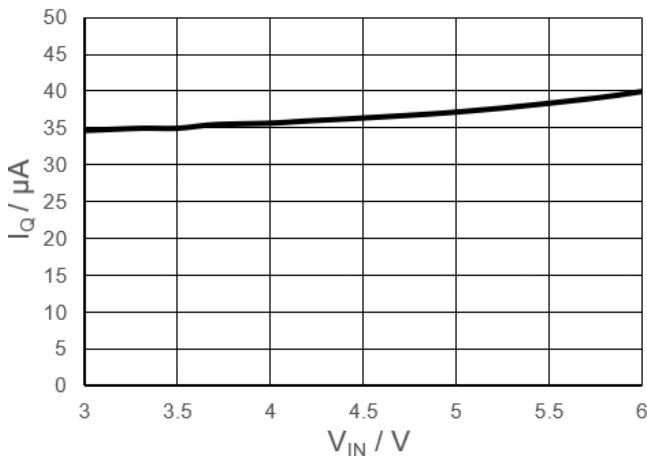

Figure 6. Quiescent Current vs Input Voltage ($C_{IN}=C_{OUT}=1\mu F$, $V_{EN}=V_{IN}$, no load, $T_A=25^\circ C$)

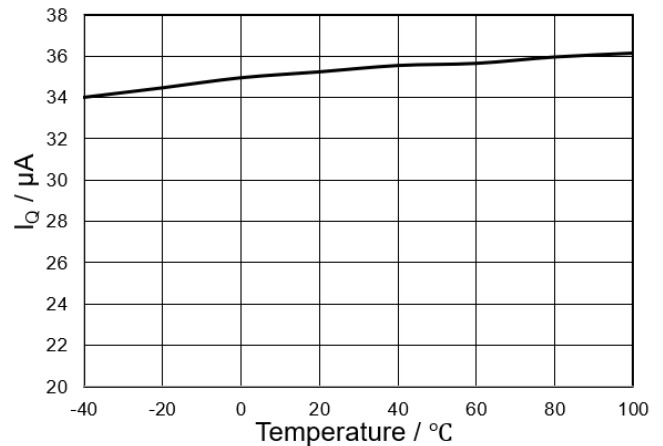

Figure 7. Quiescent Current vs Temperature ($C_{IN}=C_{OUT}=1\mu F$, $V_{EN}=V_{IN}$, no load, $V_{IN}=5V$)

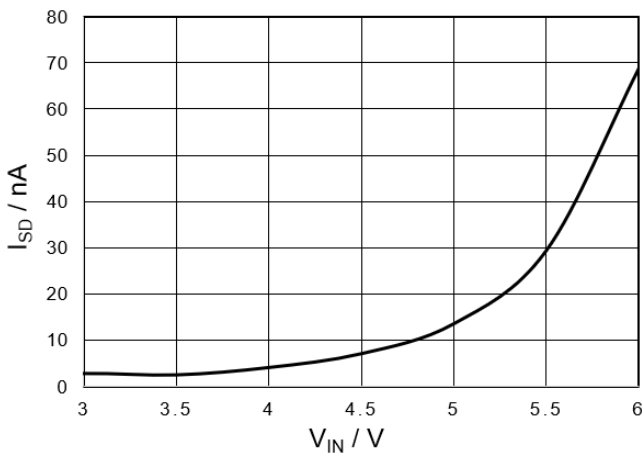

Figure 8. Shutdown Current vs Input Voltage ($C_{IN}=C_{OUT}=1\mu F$, $V_{EN}=0V$, no load, $T_A=25^\circ C$)

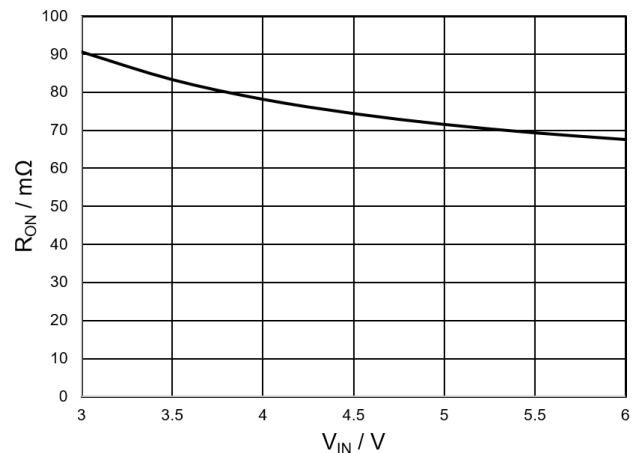

Figure 9. On-Resistance vs Input Voltage ($V_{EN}=V_{IN}$, $I_{LOAD}=1A$, $T_A=25^\circ C$)



Typical Application Waveforms

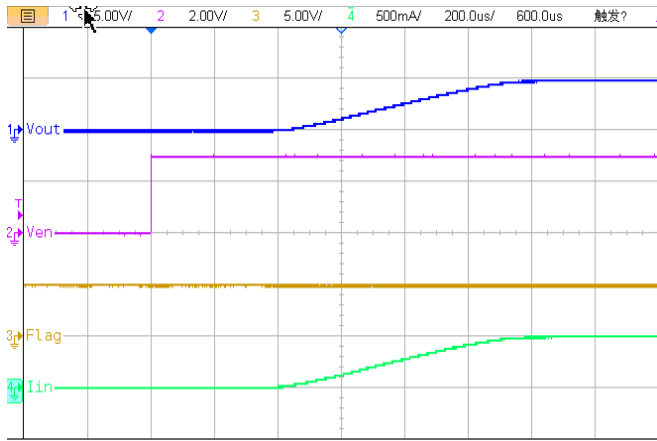

Figure 10. Start-up waveform
($V_{IN} = 5V$, $R_{SET} = 3.6k\Omega$, $R_{LOAD} = 10\Omega$, $C_{IN}=C_{OUT}=1\mu F$)

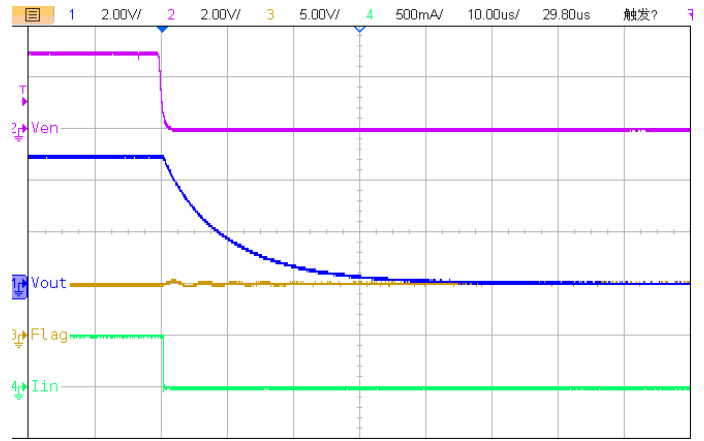

Figure 11. Turn-off waveform
($V_{IN} = 5V$, $R_{SET} = 3.6k\Omega$, $R_{LOAD} = 10\Omega$, $C_{IN}=C_{OUT}=1\mu F$)

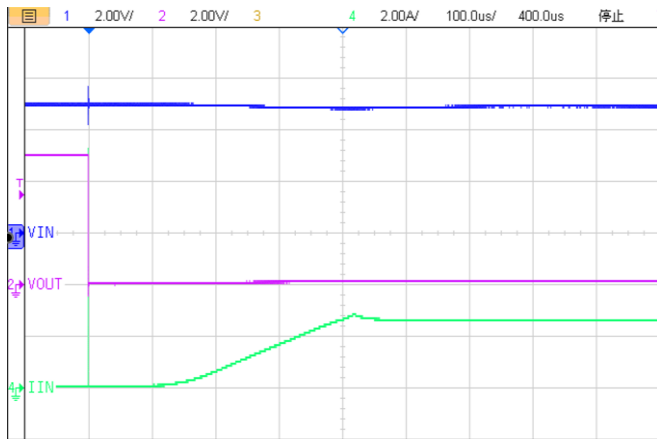

Figure 12. Output short to GND waveform
($V_{IN} = 5V$, $R_{SET} = 3.6k\Omega$, $C_{IN} = 1mF$, $C_{OUT} = 1\mu F$)

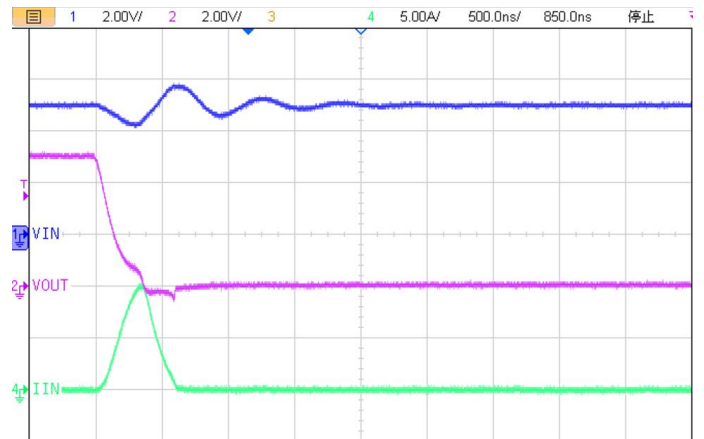

Figure 13. Zoom in Output short to GND waveform
($V_{IN} = 5V$, $R_{SET} = 3.6k\Omega$, $C_{IN} = 1mF$, $C_{OUT} = 1\mu F$)



Function Description

LPW5202 series are current limited switches that protect systems and loads which can be damaged or disrupted by the application of high currents. The devices all contain a 70mΩ P-channel MOSFET and a controller capable of working over a wide input operating range of 2.4V to 6V. The controller protects against system malfunctions through current limiting, under-voltage lockout and thermal shutdown. The current limit is adjustable from 200mA to 2.5A through an external resistor, or fixed value typical 1.35A, 1.6A or 2.35A to allow 1.1A, 1.5A or 2.1A applications.

Enable control

The EN pin controls the state of the switch. When EN is pulled high, the load switch is turned on. Activating EN continuously holds the switch in the on state so long as there is no fault. For all versions, an under-voltage on IN or a junction temperature in excess of 150°C overrides the EN control to turn off the switch. The LPW5202 does not turn off in response to an over current condition but instead remains operating in a constant current mode as long as EN is active and the thermal shutdown or under-voltage lockout have not activated.

The enable pin EN's control voltage and IN pin have independent recommended operating ranges. The EN pin voltage can be driven by a voltage level higher than the input voltage.

Reverse Voltage Protection

The LPW5202 has a reverse voltage protection feature that protects the input when output voltage is higher than the input. For a standard USB power design, this is an important feature to protect the USB host from being damaged due to the current flow from VBUS.

When the load switch is OFF, no current flows from the

output to the input. If the switch is turned on and $V_{OUT} - V_{IN}$ is higher than V_{RVP} , this feature is activated and turns off the switch. This prevents any current flow from output to input. The reverse voltage protection feature will be deactivated if the V_{OUT} is smaller than V_{IN} . FLAGB operation is independent of the reverse voltage protection and does not report a fault condition if this feature is activated

Current Limit

The current limit ensures that the current through the switch doesn't exceed a maximum value while not limiting at less than a minimum value. The current at which the parts will limit is fixed (LPW5202F/S) or adjustable through the selection of an external resistor connected to ISET (LPW5202A). The LPW5202F have a de-bounce time of 10ms, nominally, for indicator pin. At the end of this time, the FLAGB will be internally pulled down. As long as the heavy load condition continued, the LPW5202 will remain in a constant current state until the EN pin is deactivated or the thermal shutdown turns-off the switch.

Under-Voltage Lockout

The under-voltage lockout turns-off the switch if the input voltage drops below the under-voltage lockout threshold. With the EN pin active, the input voltage rising above the under-voltage lockout threshold will cause a controlled turn-on of the switch which limits current over-shoots.

Thermal Shutdown

The thermal shutdown protects the die from internally or externally generated excessive temperatures. During an over temperature condition, the switch is turned off. The switch automatically turns on again if the temperature of the die drops below the threshold temperature.



Application Information

The LPW5202A current limit is set with an external resistor connected between ISET pin and GND. This resistor is selected using the following equation:

$$R_{SET} = \frac{7900}{I_{LIM}} \quad (1)$$

Where, R_{SET} , united as $k\Omega$, is the resistor connected to ISET. I_{LIM} is the expected current limit value in mA. Resistor tolerance of 1% or less is recommended.

The relationship between R_{SET} and I_{LIM} could also be found as below diagram:

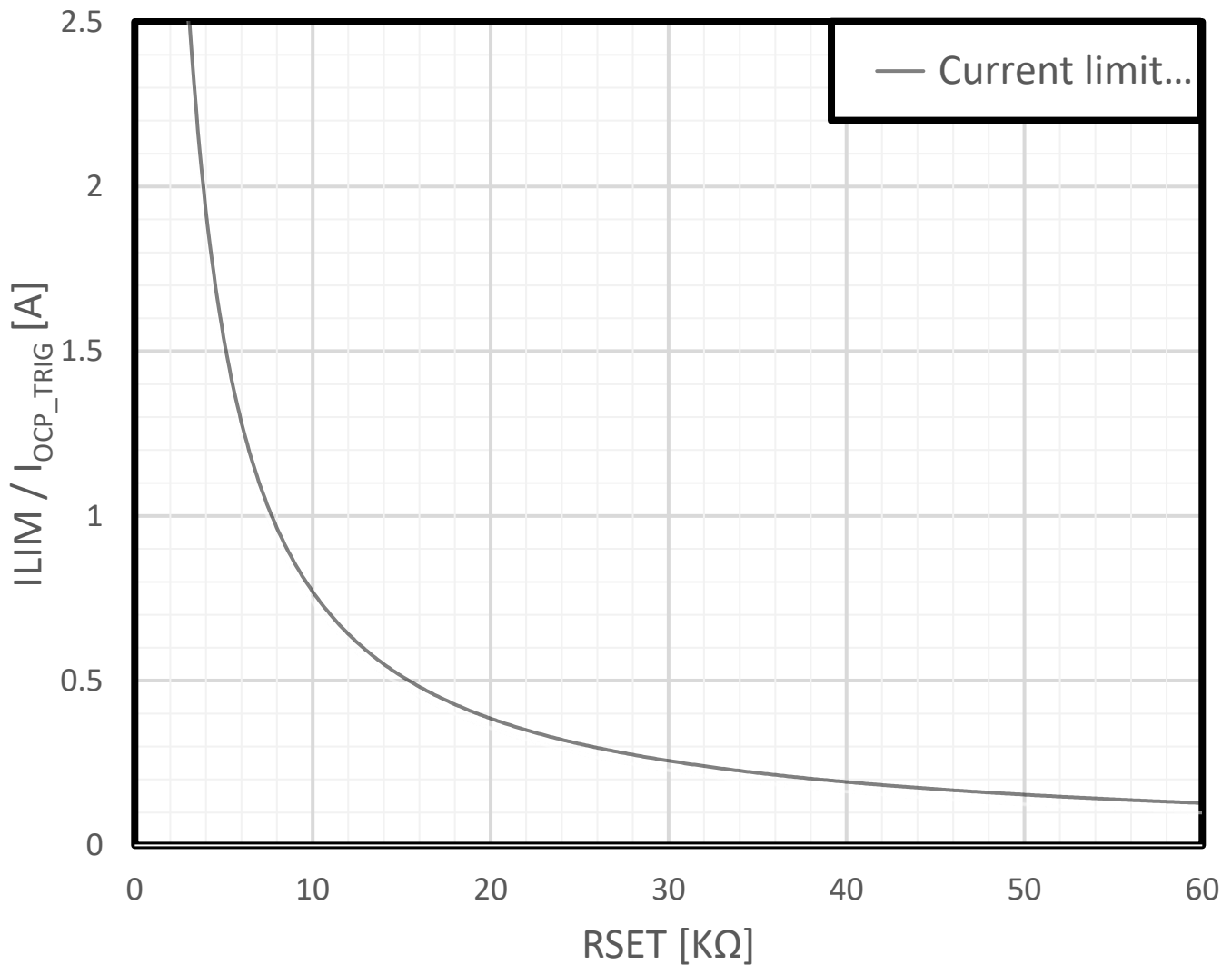
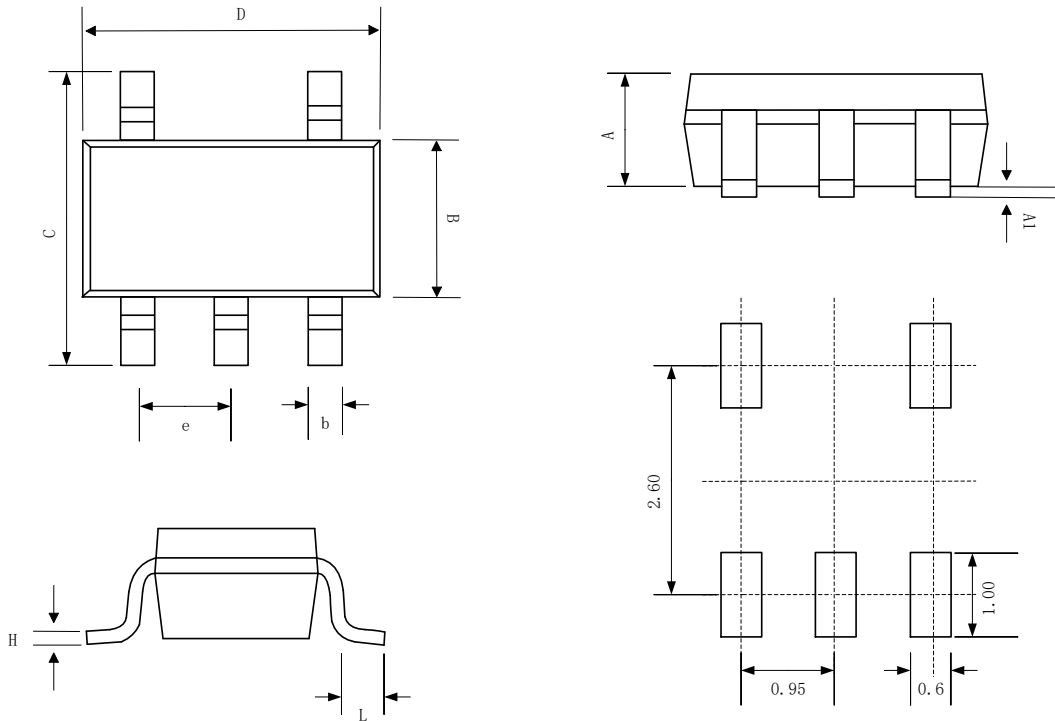

Figure 14. Current limit level and OCP trigger level



Package Information

SOT23-5



Recommended Land Pattern

SYMBOL	MILLIMETER		
	MIN	NOM	MAX
A	0.889	1.100	1.295
A1	0.000	0.050	0.152
B	1.397	1.600	1.803
b	0.28	0.35	0.559
C	2.591	2.800	3.000
D	2.692	2.920	3.120
e	0.95BSC		
H	0.080	0.152	0.254
L	0.300	0.450	0.610



Reflow Soldering Profile

Profile Feature	Sn-Pb Eutectic Assembly	Pb-Free Assembly
Preheat/Soak		
Temperature Min(T_{SMIN})	100°C	150°C
Temperature Max(T_{SMAX})	150°C	200°C
Time(T_S) from (T_{SMIN} to T_{SMAX})	60~120 seconds	60~120 seconds
Ramp-up rate (T_L to T_P)	3°C /second max	3°C /second max
Liquidous temperature(T_L)	183°C	217°C
Time(t_L) maintained above T_L	60~150 seconds	60~150 seconds
Peak package body temperature (T_P)	For users T_P must not exceed the Classification temp in Table 1. For suppliers T_P must equal or exceed the Classification temp in Table 1.	For users T_P must not exceed the Classification temp in Table 2. For suppliers T_P must equal or exceed the Classification temp in Table 2.
Time(t_P)* within 5°C of the specified classification temperature (T_C), see Figure 15	20* seconds	30* seconds
Ramp-down rate (T_P to T_L)	6°C /second max	6°C /second max
Time 25°C to peak temperature	6 minutes max	8minutes max

* Tolerance for peak profile temperature (T_P) is defined as a supplier minimum and a user maximum.

Table 1. Sn-Pb Eutectic Process - Classification Temperatures (T_C)

Package Thickness	Volume mm ³ <350	Volume mm ³ ≥350
<2.5mm	235°C	220°C
≥2.5mm	220°C	220°C

Table 2. Pb-Free Process - Classification Temperatures (T_C)

Package Thickness	Volume mm ³ <350	Volume mm ³ 350~2000	Volume mm ³ ≥350
<1.6mm	260°C	260°C	260°C
1.6mm~2.5mm	260°C	250°C	245°C
>2.5mm	250°C	245°C	245°C

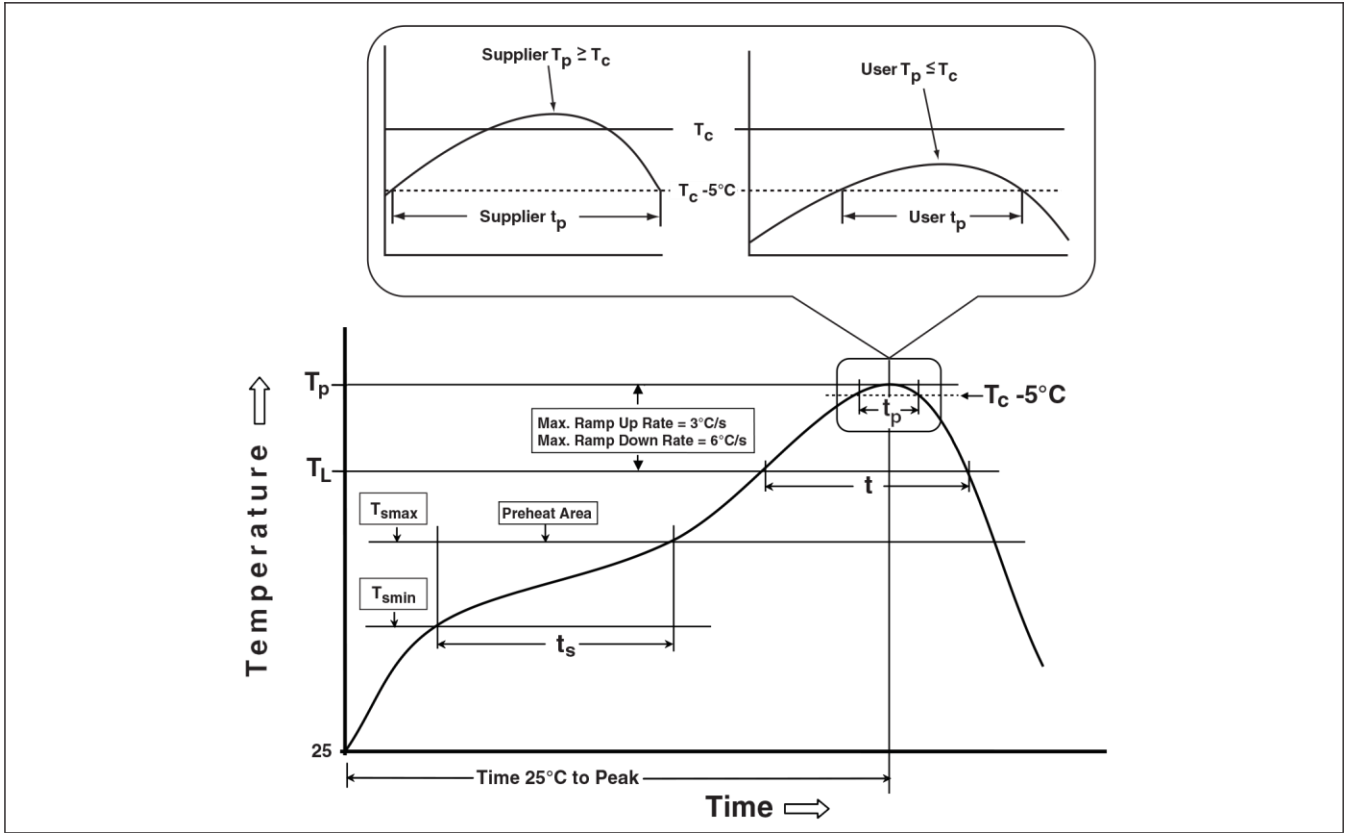
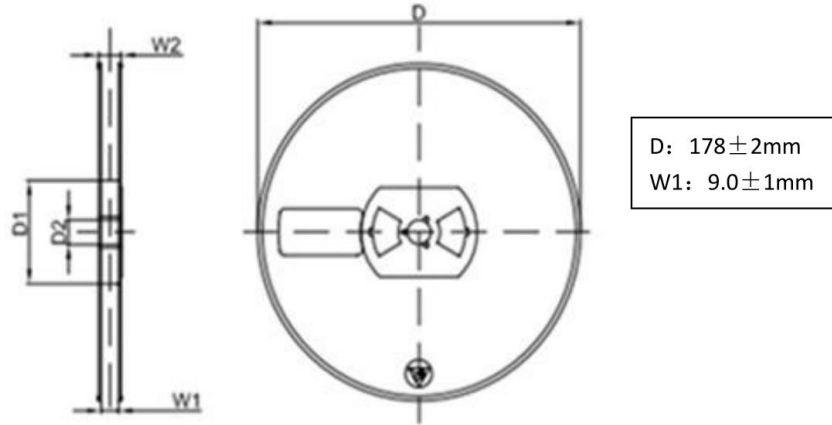

Figure 15. Classification Profile (Not to scale)



Tape and Reel Information

REEL DIMENSIONS



TAPE DIMENSIONS

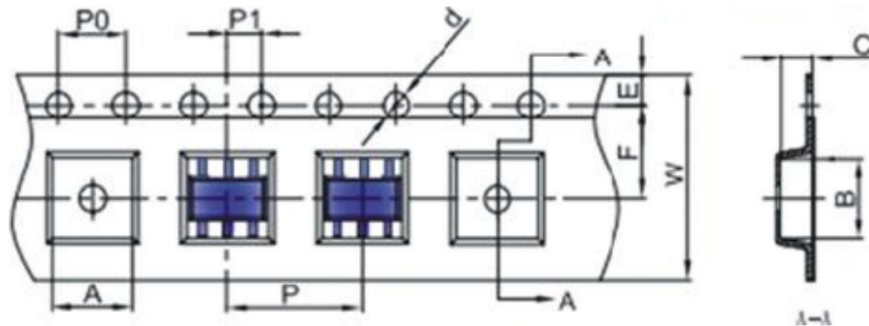

A	B	C	d	E	F	P0	P	P1	W
3.20	3.18	1.38	1.50	1.75	3.50	4.00	4.00	2.00	8.00
± 0.1	± 0.1	± 0.1	± 0.1	± 0.1	± 0.1	± 0.1	± 0.1	± 0.1	$+0.3/-0.1$

PIN1 AND TAPE FEEDING DIRECTION

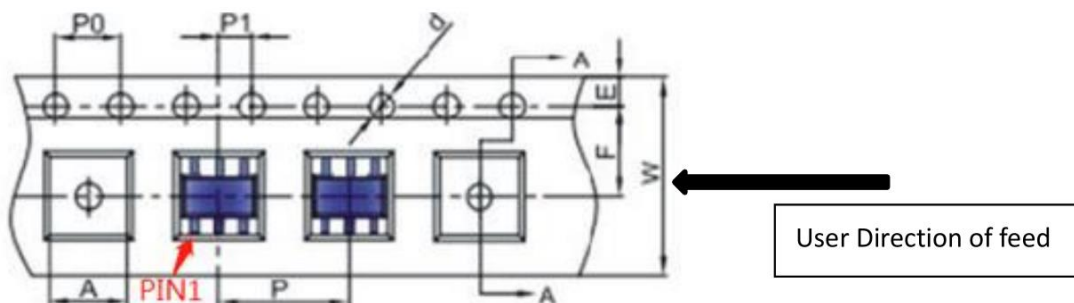

单击下面可查看定价，库存，交付和生命周期等信息

[>>LOW POWER\(微源半导体\)](#)