



Half-Bridge IPM

General Description

The LP1130 is a high efficiency synchronous buck power stage module consisting of two asymmetrical MOSFETs and an integrated driver. The MOSFETs are individually optimized for operation in the synchronous buck configuration. The high side and low side MOSFETs has ultra low $R_{DS(ON)}$ to minimize conduction losses.

A number of features are provided making the LP1130 a highly versatile power module.

Features

- ◆ Up to 30V DC VIN voltage
- ◆ 4.4V to 13.2V supply voltage
- ◆ Up to 5A output current
- ◆ Up to 500kHz Switching Frequency
- ◆ 3.3V/5V logic input compatible
- ◆ Disable function
- ◆ ROHS compliant and Lead(Pb)- free

Order Information

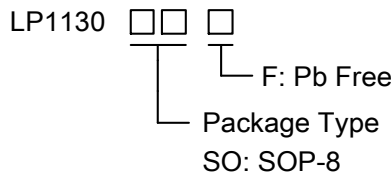

Applications

- ✧ General Wireless Power Transmitter for Consumer, Industrial and Medical Applications
- ✧ Full or Half Bridge DC-DC Switching Regulator
- ✧ Motor Driver

Typical Application Circuit

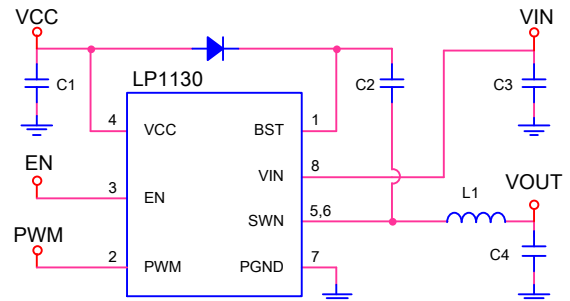

Marking Information

Device	Marking	Package	Shipping
LP1130	LPS LP1130 YWX	SOP-8	4K/REEL
Y:Production year W:Production period X:Production batch			



Functional Pin Description

Package Type		Pin Configurations
SOP-8		
Pin	Name	Description
1	BST	Upper MOSFET Floating Bootstrap Supply. A capacitor connected between BST and SW pins holds this bootstrap voltage for the high-side MOSFET as it is switched. The recommended capacitor value is between 100nF and 1.0μF. An external diode is required with the LP1130.
2	PWM	Logic-Level Input. This pin has primary control of the drive outputs.
3	EN	Active high output enable. When low, normal operation is disabled.
4	VCC	Input Supply. A 1.0μF ceramic capacitor should be connected from this pin to PGND.
5,6	SWN	Switch Node. Connect to the source of the upper MOSFET.
7	PGND	Power Ground. Should be closely connected to the source of the lower MOSFET.
8	VIN	Source for the upper MOSFET



Electrical Characteristics

(T_A=25°C, unless otherwise noted.)

Characteristic	Symbol	Condition	Min	Typ	Max	Unit
Supply						
Supply Voltage Range	V _{CC}	-	4.4	-	13.2	V
Supply Current	I _{SYS}	V _{BST} =12V, V _{EN} =0V	-	0.7	-	mA
EN Input						
Input Voltage High	V _{EN_HI}	-	2.0	-	-	V
Input Voltage Low	V _{EN_LO}	-	-	-	0.8	V
Hysteresis	V _{EN_HYS}	-	-	300	-	mV
Input Current	I _{EN}	No internal pull-up or pull-down resistors	-1.0	-	+1.0	μA
PWM Input						
Input Voltage High	V _{PWM_HI}	-	2.0	-	-	V
Input Voltage Low	V _{PWM_LO}	-	-	-	0.8	V
Hysteresis	V _{PWM_HYS}	-	-	300	-	mV
Input Current	I _{PWM}	No internal pull-up or pull-down resistors	-1.0	-	+1.0	μA
Under Voltage Lockout						
UVLO Startup	V _{UVLO}	-	-	4.3	-	V
Hysteresis	V _{UVLO-HYS}	-	-	0.3	-	V
POWER MOSFET						
Zero Gate Voltage Drain Current	I _{DSS}	V _{IN} =30V, EN=0			1	μA
High side switch On-Resistance	R _{DS(ON)-H}	V _{CC} =9V		9		mΩ
Low side switch On-Resistance	R _{DS(ON)-L}			16		
THERMAL SHUTDOWN						
Thermal shutdown threshold	T _{SD}			160		°C
Thermal shutdown threshold hysteresis	T _{SD-HYS}			30		°C



Packaging Information

SOP-8

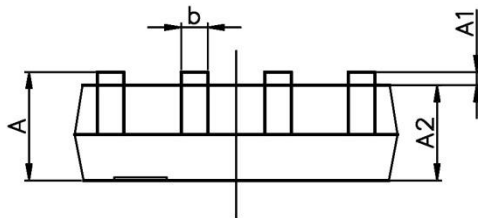
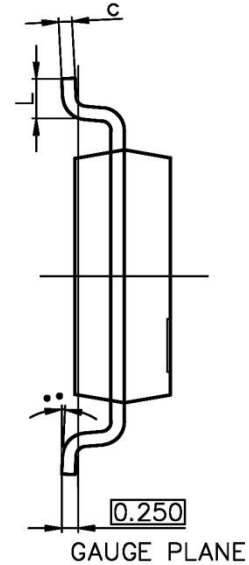
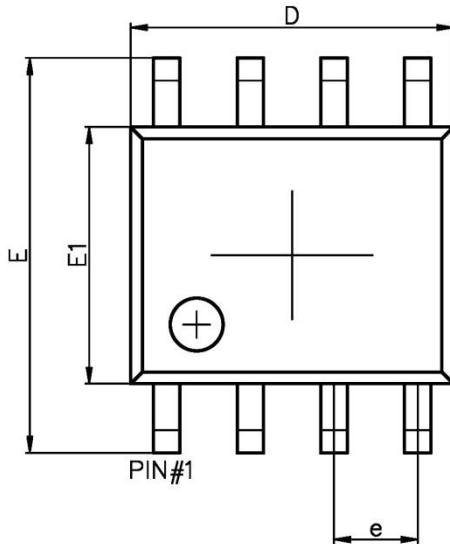

Symbol	Dimensions In Millimeters		Dimensions In Inches	
	Min.	Max.	Min.	Max.
A	1.350	1.750	0.053	0.069
A1	0.100	0.250	0.004	0.010
A2	1.350	1.550	0.053	0.061
b	0.330	0.510	0.013	0.020
c	0.170	0.250	0.007	0.010
D	4.800	5.000	0.189	0.197
e	1.270 (BSC)		0.050 (BSC)	
E	5.800	6.200	0.228	0.244
E1	3.800	4.000	0.150	0.157
L	0.400	1.270	0.016	0.050
θ	0°	8°	0°	8°

单击下面可查看定价，库存，交付和生命周期等信息

[>>LOW POWER\(微源半导体\)](#)