

Ultra low IQ Synchronous Boost Converter

General Description

The LP62610 device is a synchronous boost converter with ultra-low quiescent current. It features a true-shutoff function that disconnects the input and output during shutdown and output short-circuit conditions.

The LP62610 only consumes 1uA quiescent current under light load condition and can achieve up to 75% efficiency at 20uA load. It can achieve up to 93% efficiency at 200mA load from 3.3 V to 5V conversion.

Features

- ◆ Up to 95% efficiency
- ◆ Output to Input Disconnect at Shutdown Mode
- ◆ Shut-down current:<0.1uA
- ◆ Over Output Voltage Protection
- ◆ Over Current Protection
- ◆ Over Temperature Protection
- ◆ Internal Compensation of Soft-start
- ◆ 1.2MHz fixed frequency switching

Order Information

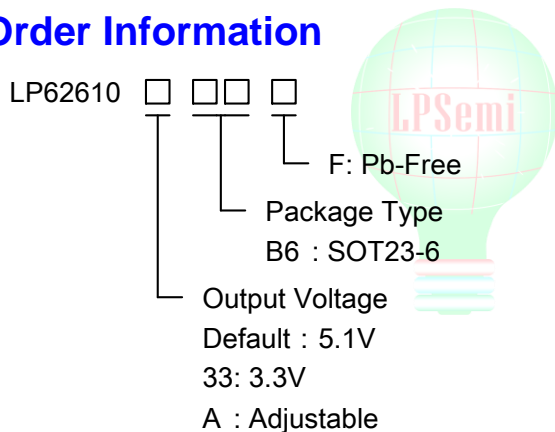

Typical Application Circuit

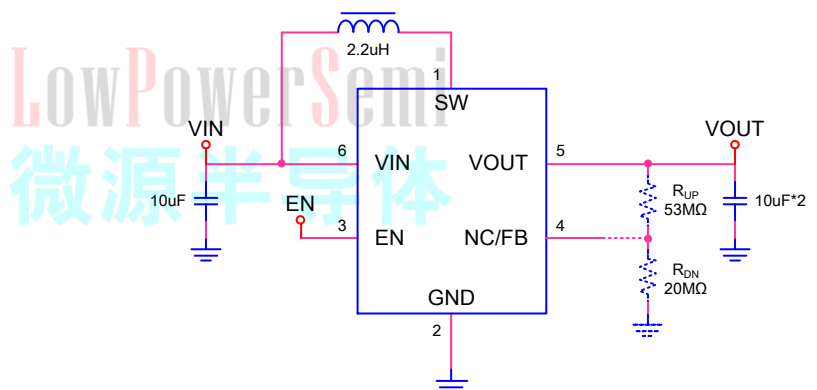

Applications

- ✧ Tablet, MID
- ✧ Smart Phone
- ✧ Power Bank

Marking Information

Device	Marking	Package	Shipping
LP62610B6F	LPS 61AYWX	SOT23-6	3K/REEL
LP62610-33B6F	LPS 61EYWX	SOT23-6	3K/REEL
LP62610AB6F	LPS 61DYWX	SOT23-6	3K/REEL

Marking indication:
Y:Production year W:Production week X: Series Number

Functional Pin Description

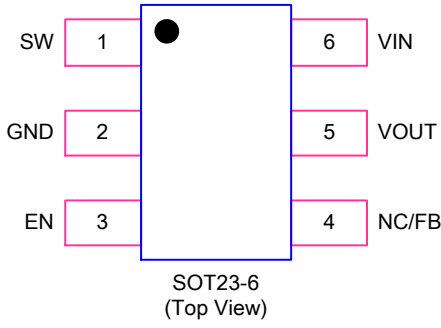
Package Type	Pin Configurations
SOT23-6	 <p style="text-align: center;">SOT23-6 (Top View)</p>

Pin Description

Pin No.	Name	Description
1	SW	Pin for switching.
2	GND	Ground pin.
3	EN	Chip enable pin. Logic high voltage enables the device; logic low voltage disables the device. Do not leave it floating.
4	NC	No Connect.
	FB (LP62610A)	Feedback pin. The feedback voltage is 1.36V.
5	VOUT	Voltage output pin.
6	VIN	Voltage supply input pin.

Absolute Maximum Ratings ^{Note 1}

✧ VIN and EN to GND	-----	6.5V
✧ VOUT to GND	-----	8V
✧ SW to GND	-----	9V
✧ Maximum Junction Temperature	-----	150°C
✧ Maximum Soldering Temperature (at leads, 10 sec)	-----	260°C

Note 1. Stresses beyond those listed under “Absolute Maximum Ratings” may cause permanent damage to the device. These are stress ratings only, and functional operation of the device at these or any other conditions beyond those indicated in the operational sections of the specifications is not implied. Exposure to absolute maximum rating conditions for extended periods may affect device reliability.

Thermal Information

✧ Maximum Power Dissipation (SOT23-6, P _D , T _A =25°C)	-----	0.45W
✧ Thermal Resistance (SOT23-6, J _A)	-----	250°C/W

ESD Susceptibility

✧ HBM(Human Body Mode)	-----	2KV
✧ MM(Machine Mode)	-----	200V

Recommended Operating Conditions

✧ Ambient Temperature Range	-----	-40°C to 85°C
-----------------------------	-------	---------------

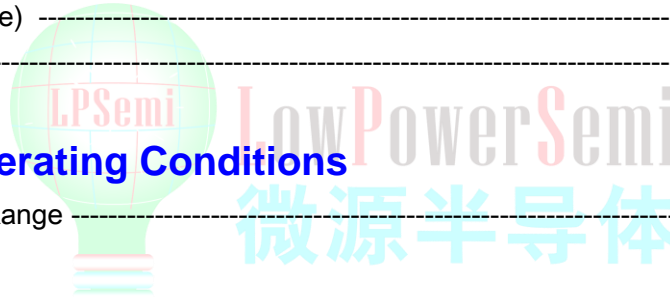

Electrical Characteristics

($V_{IN}=3V$, $C_{IN}=10\mu F$, $C_{OUT}=22\mu F$, $L=2.2\mu H$)

Parameter	Condition	Min	Typ	Max	Units
Output Voltage	LP62610B6F	5.0	5.1	5.2	V
	LP62610-33B6F	3.234	3.3	3.366	V
Feedback Voltage	LP62610AB6F	1.333	1.36	1.388	V
Supply Voltage		1		5	V
Input UVLO	$I_{OUT}=1mA$		0.8		V
Supply Current	$V_{EN}=High$, $V_{IN}=5V$, No load		1		μA
Supply Current(Shutdown)	$V_{EN}=0V$, $V_{IN}=5V$		0.05	1	μA
Switching Frequency			1200		KHz
EN Input Low Voltage				0.3	V
EN Input High Voltage		1			V
EN Input Current	$V_{EN}=5V$		0.1		μA
Low-side Current Limit	$V_{IN}=3.5V$		1		A
Star-up Current Limit			1		A
High-side On Resistance	$I_{DS}=-100mA$		160		$m\Omega$
Low-side On Resistance	$I_{DS}=100mA$		220		$m\Omega$
Output Discharge Resistance	$V_{OUT}=5V$, $V_{EN}=0V$		2		$K\Omega$
Thermal Shutdown			150		$^{\circ}C$
Thermal Shutdown Hysteresis			25		$^{\circ}C$

Application Curves

($C_{IN}=10\mu F$, $C_{OUT}=22\mu F$, $L=2.2\mu H$)

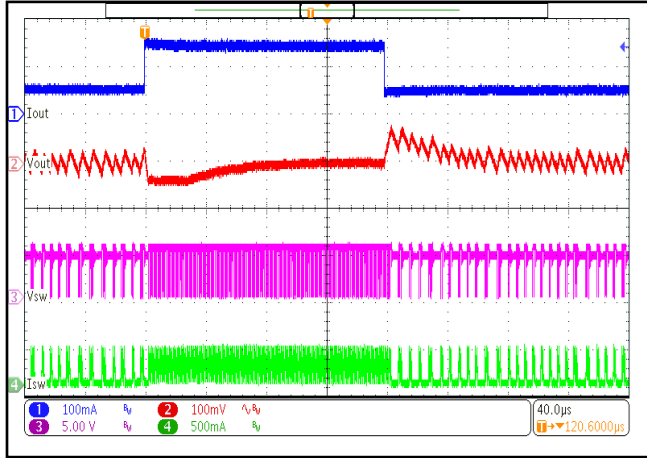

$V_{IN}=4.2V$, $I_{OUT}=50mA$ to $150mA$

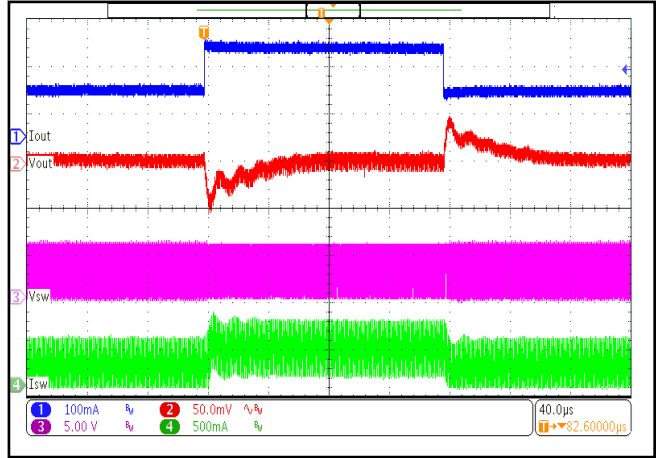

$V_{IN}=4.2V$, $I_{OUT}=100mA$ to $200mA$

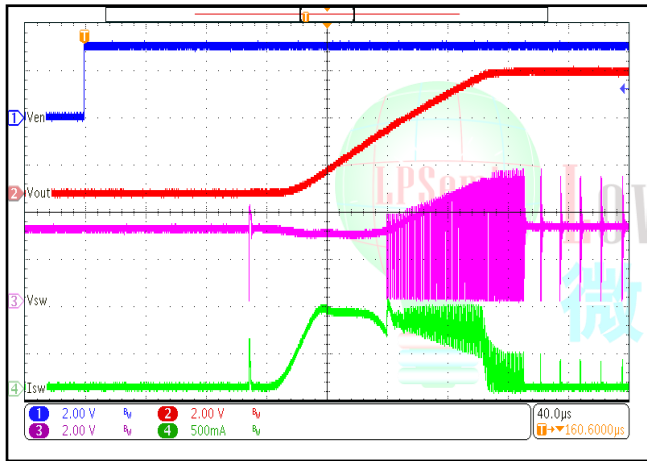

$V_{IN}=3V$, No Load

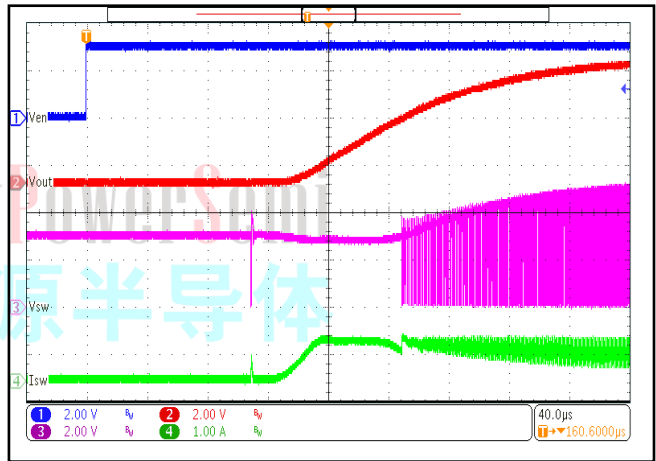

$V_{IN}=3V$, $R_{LOAD}=20\Omega$

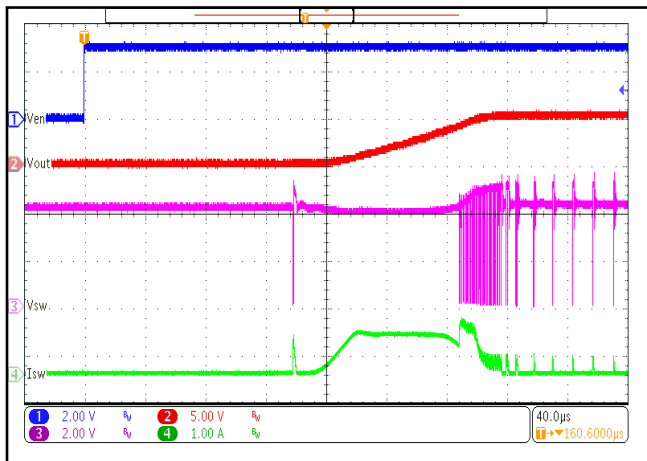

$V_{IN}=4.2V$, No Load

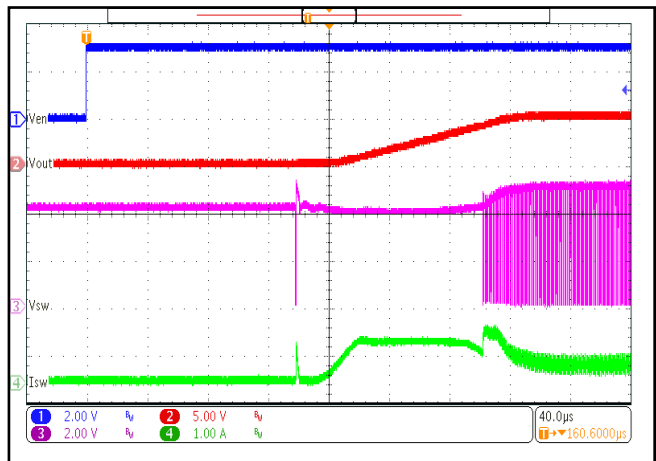

$V_{IN}=4.2V$, $R_{LOAD}=20\Omega$

Typical Operating Characteristics

($C_{IN}=10\mu F$, $C_{OUT}=22\mu F$, $L=2.2\mu H$)

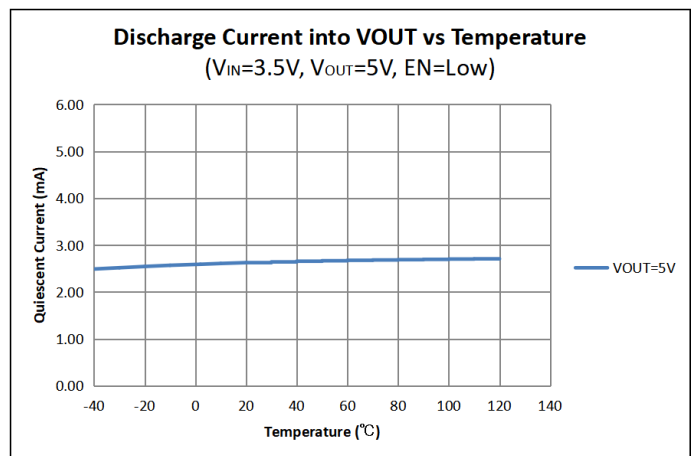
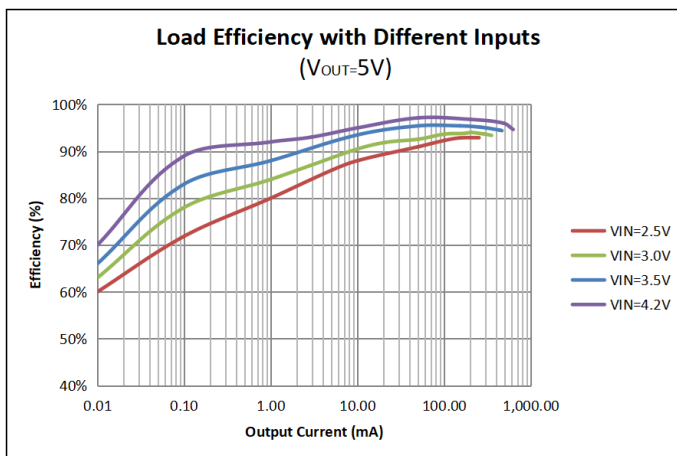
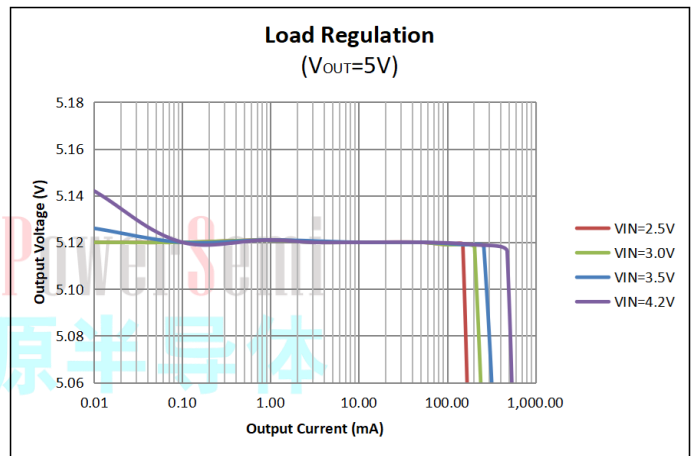
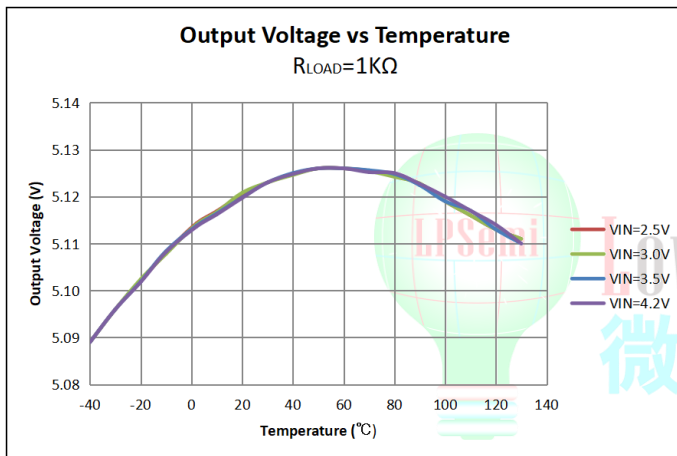
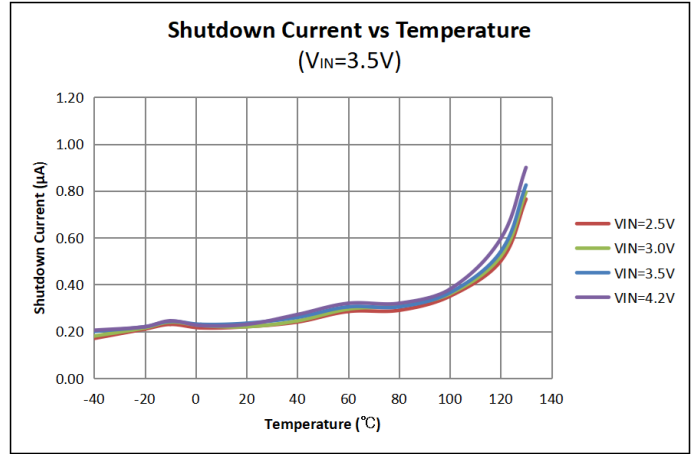
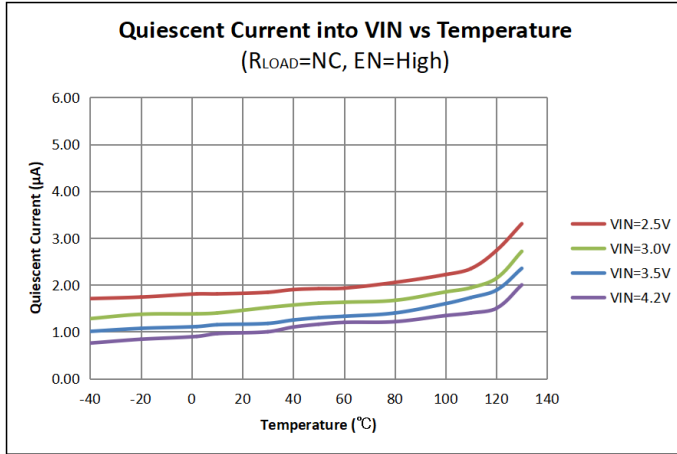

Application Information

The LP62610 uses a synchronous 1.2MHz fixed frequency with 1uA ultra-low quiescent current. It is designed for alkaline battery, coin-cell battery, Li-ion or Li-polymer battery powered systems, which requires long battery running time and tiny solution size.

The LP62610 uses cycle-by-cycle overcurrent protection. If the inductor peak current reaches the current limit, the chip turns off the main switch to stop the further increase in input current. In this case, the output voltage will decrease until the power balance between the input and output is reached.

Short-Circuit Protection

Unlike most boost converters, the LP62610 allows output shorts. In the case of a short circuit, the LP62610 first turns off the NMOS when the current detected by the chip reaches the current limit. When V_{OUT} falls below V_{IN} , the device enters a linear mode of operation with the same current limit as the start-up period. In addition, the thermal shutdown circuits disable switching if the die temperature rises above 150°C.

Setting the Output Voltage

Set the output voltage by selecting the resistive voltage divider ratio. The voltage divider drops the output voltage to the 1.36V feedback voltage. Determine the resistor R_{UP} and R_{DN} by the following equation:

$$V_{OUT} = \left(\frac{R_{UP}}{R_{DN}} + 1 \right) \times V_{FB}$$

Layout Guide

For high frequency switching power supplies, the PCB layout is important step in system application design. In order to let IC achieve good regulation, high efficiency and stability, it is strongly recommended the power components (Inductor, input and output capacitor) should be placed as close as possible to chip. The set traces should be wide and short.



Packaging Information

SOT23-6

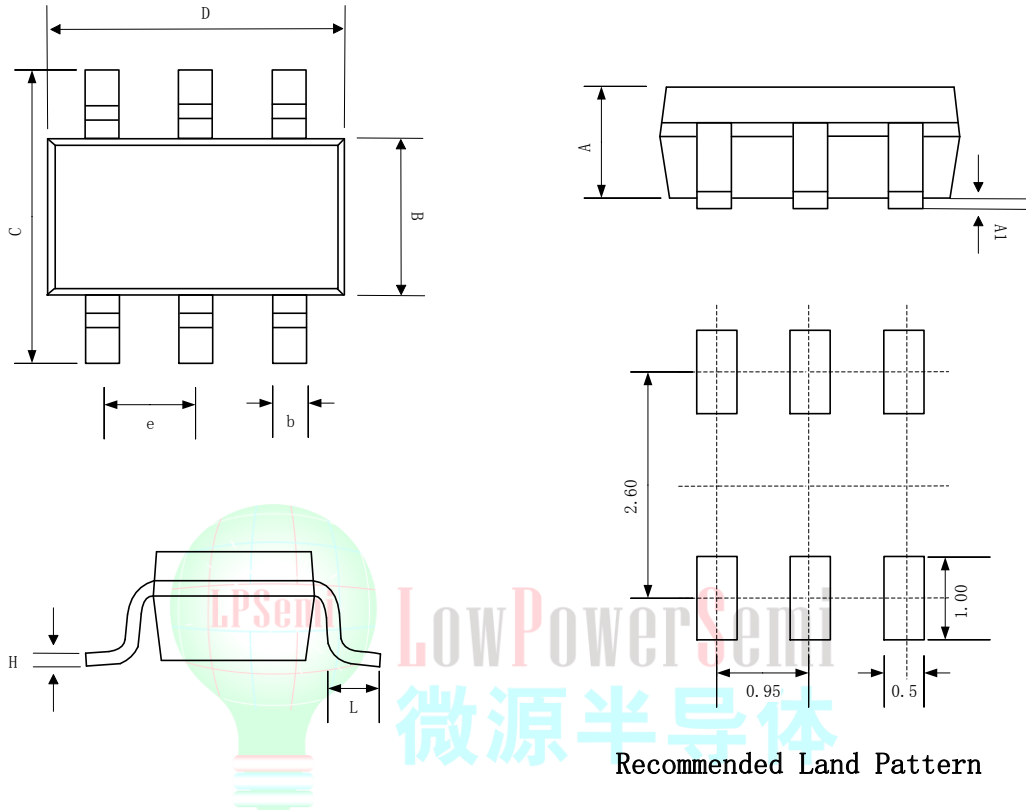

SYMBOL	MILLIMETER		
	MIN	NOM	MAX
A	0.889	1.100	1.295
A1	0.000	0.050	0.152
B	1.397	1.600	1.803
b	0.28	0.35	0.559
C	2.591	2.800	3.000
D	2.692	2.920	3.120
e	0.95BSC		
H	0.080	0.152	0.254
L	0.300	0.450	0.610

Classification of IR Reflow Profile

Profile Feature	Sn-Pb Eutectic Assembly	Pb-Free Assembly
Preheat/Soak		
Temperature Min(T_{SMIN})	100°C	150°C
Temperature Max(T_{SMAX})	150°C	200°C
Time(T_s) from (T_{SMIN} to T_{SMAX})	60~120 seconds	60~120 seconds
Ramp-up rate (T_L to T_P)	3°C/second max	3°C/second max
Liquidous temperature(T_L)	183°C	217°C
Time(t_L) maintained above T_L	60~150 seconds	60~150 seconds
Peak package body temperature (T_P)	For users T_P must not exceed the Classification temp in Table 1. For suppliers T_P must equal or exceed the Classification temp in Table 1.	For users T_P must not exceed the Classification temp in Table 2. For suppliers T_P must equal or exceed the Classification temp in Table 2.
Time(t_p)* within 5°C of the specified classification temperature(T_c), see Figure 1	20* seconds	30* seconds
Ramp-down rate (T_P to T_L)	6°C/second max	6°C/second max
Time 25°C to peak temperature	6 minutes max	8 minutes max
* Tolerance for peak profile temperature (T_P) is defined as a supplier minimum and a user maximum.		

Table 1 Sn-Pb Eutectic Process - Classification Temperatures (T_c)

Package Thickness	Volume mm^3 <350	Volume mm^3 ≥350
<2.5mm	235°C	220°C
≥2.5mm	220°C	220°C

Table 2 Pb-Free Process - Classification Temperatures (T_c)

Package Thickness	Volume mm^3 <350	Volume mm^3 350~2000	Volume mm^3 ≥350
<1.6mm	260°C	260°C	260°C
1.6mm~2.5mm	260°C	250°C	245°C
>2.5mm	250°C	245°C	245°C

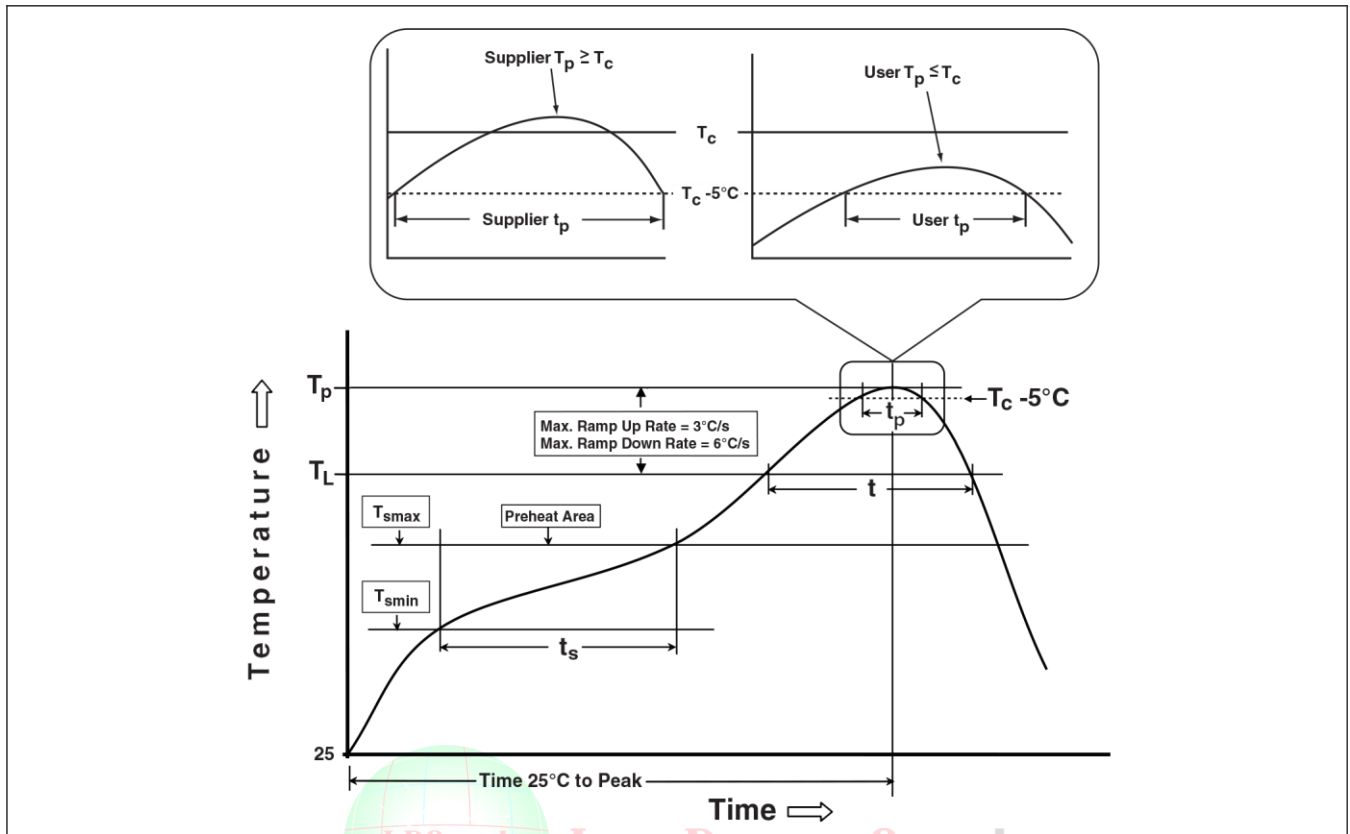

Figure 1 Classification Profile (Not to scale)

Products shipped conform to “Rohs” standards;

Moisture Sensitivity Level: MSL3 (CONDITION: $\cong 30\text{ }^\circ\text{C}/60\%\text{RH}$ 、Time control:168 hours) ;

单击下面可查看定价，库存，交付和生命周期等信息

[>>LOW POWER\(微源半导体\)](#)