



1.2A Single-chip Li-ion and Li-POL Charge

General Description

The LP28012 is a complete constant-current/ constant voltage linear charger for single cell lithium-ion batteries. Its TDFN-10 package and low external component count make the LP28012 ideally suited for portable applications. No external sense resistor is needed, and no blocking diode is required due to the internal MOSFET architecture. Thermal feedback regulates the charge current to limit the die temperature during high power operation or high ambient temperature. The charge voltage is fixed at 4.2V/4.35V, and the charge current can be I_{SET} rammed externally with a single resistor. The LP28012 automatically terminates the charge cycle when the charge current drops to 1/10th the I_{SET} rammed value after the final float voltage is reached.

When the input supply is removed, the LP28012 automatically enters a low current state, dropping the battery drain current to less than 1µA.

Other features include charge current monitor, under voltage lockout, automatic recharge and a status pin to indicate charge termination and the presence of an input voltage.

Order Information

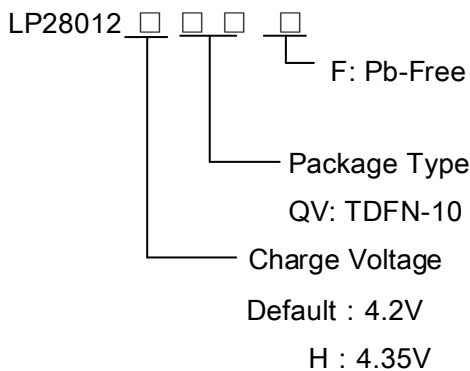

Applications

- ✧ Portable Media Players/Game
- ✧ Power Bank
- ✧ PDA/MID
- ✧ Bluetooth Applications

Features

- ◆ Very Low Power Dissipation
- ◆ Short-circuit protection
- ◆ Programmable Charge Current Up to 1200mA
- ◆ No MOSFET, Sense Resistor or Blocking Diode Required
- ◆ Constant-Current/Constant-Voltage Operation with Thermal Regulation to Maximize Charge Rate Without Risk of Overheating
- ◆ 1µA Leakage Current in Shutdown
- ◆ Drainage Charge Current Thermal Regulation Status Outputs for LED or System Interface
- ◆ Indicates Charge and Fault Conditions
- ◆ Consumption Available in TDFN-10 Package
- ◆ RoHS Compliant and 100% Lead (Pb)-Free

Typical Application Circuit

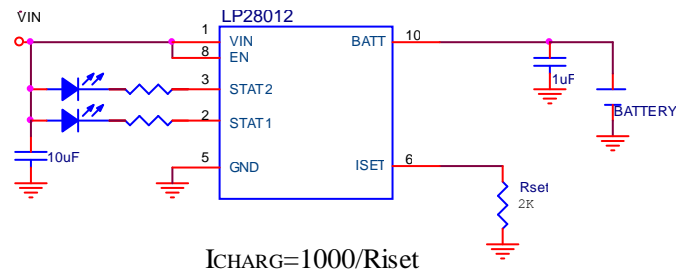

Marking Information

Device	Marking	Package	Shipping
LP28012		QV:TDFN-10	3K/REEL
LP28012H			



Functional Pin Description

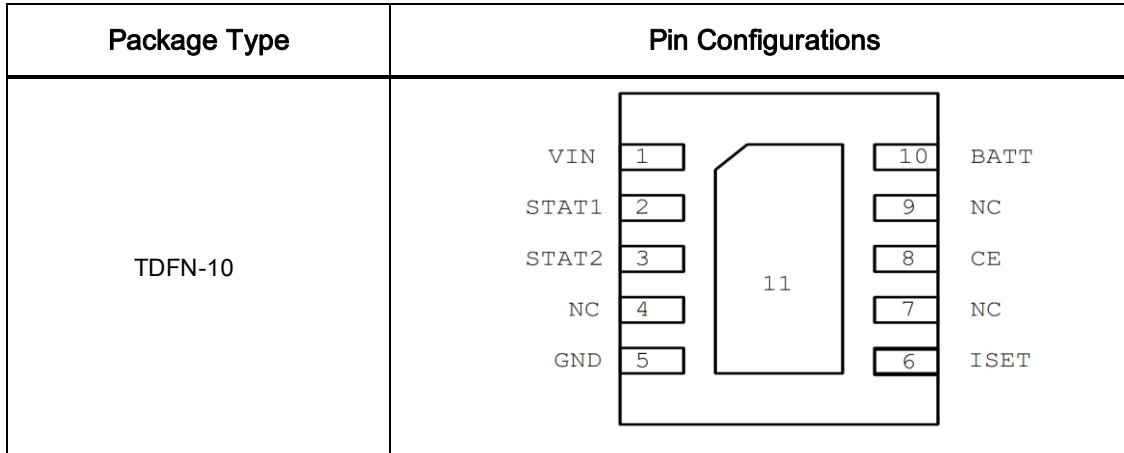

Pin Description

PIN No.	PIN NAME	DESCRIPTION
1	VIN	VIN is the input power source. Connect to a wall adapter.
2	STAT1	Open-Drain Charge Status Output. When the battery is charging, the STAT pin could be pulled High by an external pull high resistor. When the charge cycle is completed, the pin is pulled Low.
3	STAT2	Open-Drain Charge Status Output. When the battery is charging, the STAT pin is pulled low by an internal NMOS. When the charge cycle is completed, the pin could be pulled High by an external pull high resistor.
4,7,9	NC	No Connector.
5,11	GND	GND is the connection to system ground.
6	ISET	Charge Current Program, Charge Current Monitor and Shutdown Pin. The charge current is programmed by connecting a 1% resistor(R_{PROG})to ground. When charging in constant-current mode, this pin servos to 2V. In all modes, the voltage on this pin can be used to measure the charge current using the following fomula. $I_{set}=1000/R_{iset}$.
8	EN	Chip enable pin. Charging when the pin Voltage is floating and high, discharge when the pin in Low voltage.
10	BATT	BAT is the connection to the battery. Typically a 10 μ F Tantalum capacitor is needed for stability when there is no battery attached. When a battery is attached, only a 0.1 μ F ceramic capacitor is required.



Function Block Diagram

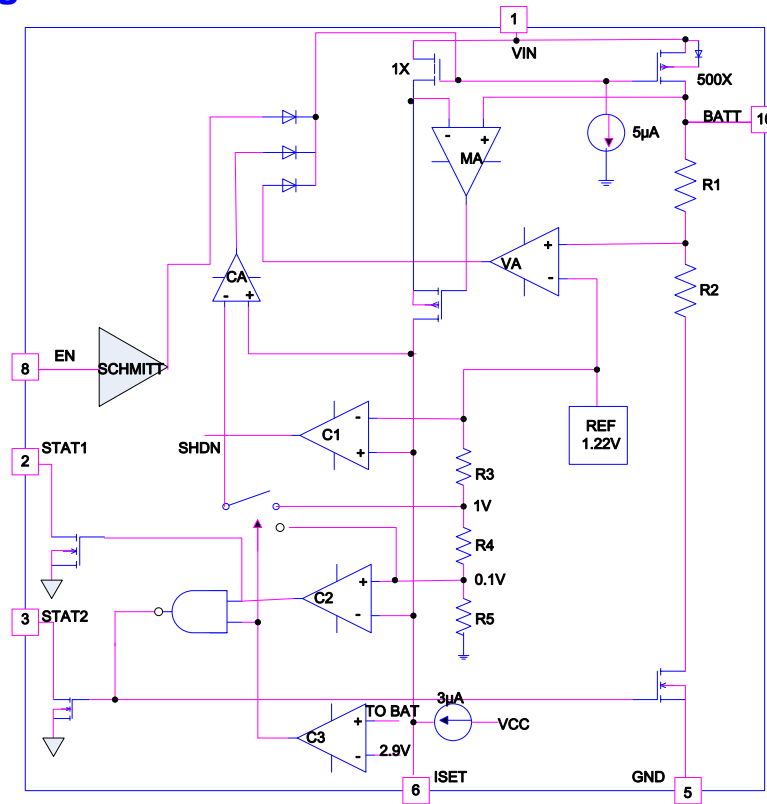

Absolute Maximum Ratings ^{Note 1}

- ◇ Input Voltage to GND -----0.3V to 7V
- ◇ BAT Short-Circuit Duration ----- Continuous
- ◇ BAT Pin Current ----- 1200mA
- ◇ Other pin to GND -----0.3V to 6V
- ◇ Maximum Junction Temperature ----- 150°C
- ◇ Operating Junction Temperature Range (TJ) ----- -40°C to 85°C
- ◇ Maximum Soldering Temperature (at leads, 10 sec) ----- 260°C

Note 1. Stresses beyond those listed under “Absolute Maximum Ratings” may cause permanent damage to the device. These are stress ratings only, and functional operation of the device at these or any other conditions beyond those indicated in the operational sections of the specifications is not implied. Exposure to absolute maximum rating conditions for extended periods may affect device reliability.

Thermal Information

- ◇ Maximum Power Dissipation (PD,TA=25°C) ----- 1.5W
- ◇ Thermal Resistance (JA) ----- 46°C/W

ESD Susceptibility

- ◇ HBM(Human Body Mode) ^{Note 2} ----- 2KV
- ◇ MM(Machine Mode) ^{Note 3} ----- 200V

Note 2. The Human body model (HBM) is a 100pF capacitor discharged through a 1.5kΩ resistor into each pin. The testing is done according JEDEC.

Note 3. Machine Model (MM) is a 200pF capacitor discharged through a 500nH inductor with no series resistor into each pin. The testing is done according JEDEC.



Electrical Characteristics

(The specifications which apply over the full operating temperature range, otherwise specifications are at $T_A = 25^\circ\text{C}$. $V_{IN} = 5\text{V}$, unless otherwise noted.)

SYMBOL	PARAMETER	CONDITIONS	MIN	TYP.	MAX	UNITS
V_{IN}	Adapter/USB Voltage Range		2.65	5	7	V
I_{CC}	Input Supply Current	Charge Mode, $R_{ISET} = 10\text{k}$		300	2000	uA
		Standby Mode (Charge Terminated)		200	500	
		Shutdown Mode (R_{ISET} Not Connected/ $V_{EN}=0\text{V}$)		1	5	
V_{FLOAT}	Regulated Output (Float) Voltage	$0^\circ\text{C} \leq T_A \leq 85^\circ\text{C}$, $I_{BAT} = 40\text{mA}$, LP28012	4.158	4.2	4.242	V
		$0^\circ\text{C} \leq T_A \leq 85^\circ\text{C}$, $I_{BAT} = 40\text{mA}$, LP28012H	4.298	4.35	4.402	
I_{BAT}	BAT Pin Current	$R_{ISET} = 1\text{k}$, Current Mode		1000		mA
		$R_{ISET} = 2\text{k}$, Current Mode		500		
		Standby Mode, $V_{BAT} = 4.2\text{V}$ Shutdown Mode ($V_{EN}=0\text{V}$)	0	-2.5	-6	uA
		Sleep Mode, $V_{CC} = 0\text{V}$		± 1	± 2	
I_{TRIKL}	Trickle Charge Current	$V_{BAT} < V_{TRIKL}$, $R_{SET} = 2\text{k}$	45	50	55	mA
V_{TRIKL}	Trickle Charge Threshold Voltage	$R_{ISET} = 10\text{k}$, V_{BAT} Rising	2.8	2.9	3.0	V
V_{TRHYS}	Trickle Charge Hysteresis Voltage	$R_{ISET} = 10\text{k}$		120		mV
V_{UV}	VCC Under voltage Lockout Threshold	From VCC Low to High		3.9		V
V_{UVHYS}	VCC Under voltage Lockout Hysteresis		150	200	300	mV
V_{ASD}	VCC – V_{BAT} Lockout Threshold Voltage	VCC from Low to High	70	100	140	mV
		VCC from High to Low	5	30	50	mV
I_{TERM}	C/10 Termination Current Threshold	$R_{ISET} = 10\text{k}$	0.085	0.10	0.115	mA/mA
		$R_{ISET} = 2\text{k}$	0.085	0.10	0.115	mA/mA
V_{ISET}	ISET Pin Voltage	$R_{ISET} = 10\text{k}$, Current Mode	1.8	2	2.2	V
I_{STAT}	STAT Pin Weak Pull-Down Current	$V_{STAT} = 5\text{V}$		5		uA
V_{STAT}	STAT Pin Output Low Voltage	$I_{STAT} = 5\text{mA}$		0.35	0.6	V
ΔV_{RESTAT}	Recharge Battery Threshold Voltage	$V_{FLOAT} - V_{RESTAT}$	100	150	200	mV
T_{LIM}	Junction Temperature in Constant Temperature Mode			120		$^\circ\text{C}$
R_{ON}	Power FET "ON" Resistance (Between VCC and BAT)			600		m Ω
T_{SS}	Soft-Start Time	$I_{BAT} = 0$ to $I_{BAT} = 850\text{V}/R_{ISET}$		100		uS
I_{ISET}	ISET Pin Pull-Up Current			150		uA



TYPICAL CHARACTERISTICS
DROPOUT VOLTAGE
VS
JUNCTION TEMPERATURE

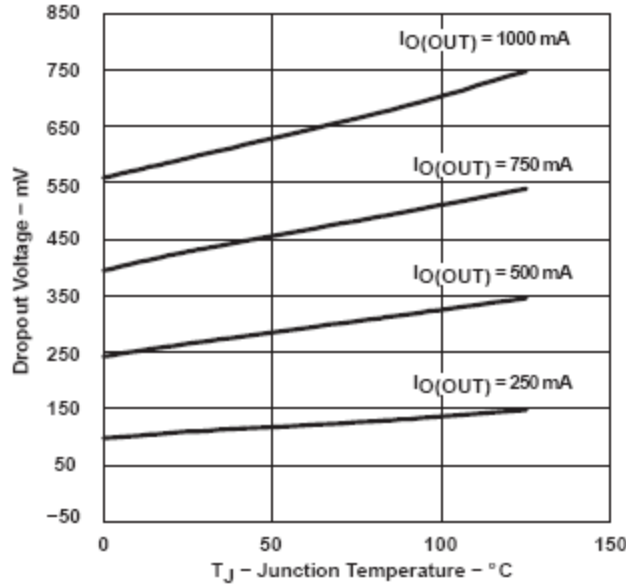

Figure 1

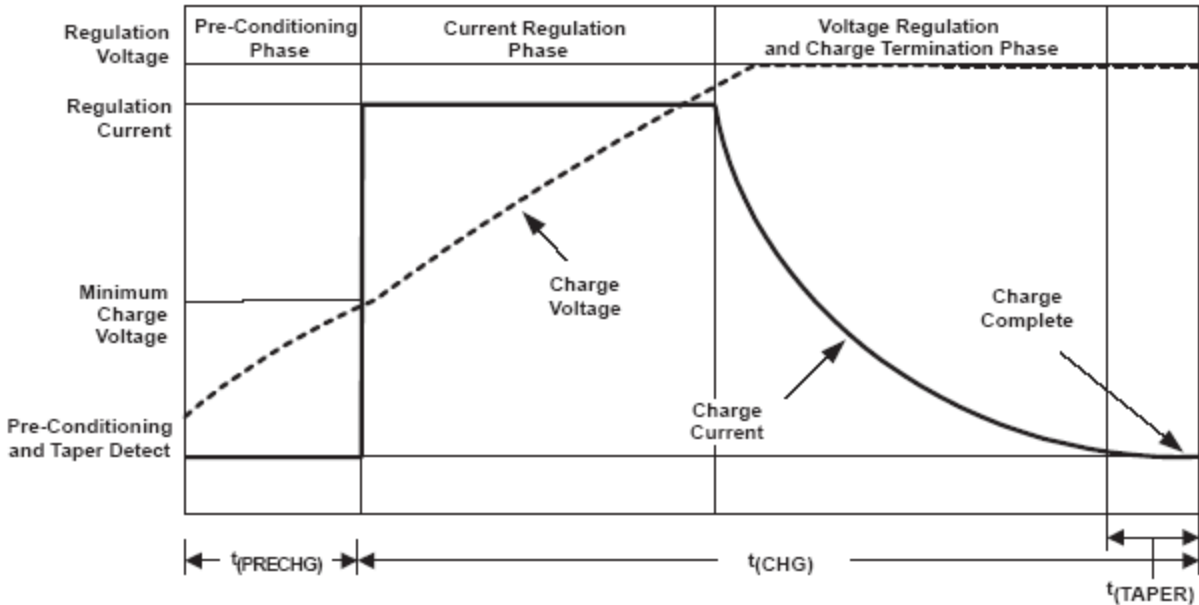

Figure 2. Typical Charging Profile



Application Information

The LP28012 is a single cell lithium-ion battery charger using a constant-current/constant-voltage algorithm. It can deliver up to 1200mA of charge current (using a good thermal PCB layout) with a final float voltage accuracy of ±1% (4.2V) / ±1.2% (4.35V). The LP28012 includes an internal P-channel power MOSFET and thermal regulation circuitry. No blocking diode or external current sense resistor is required; thus, the basic charger circuit requires only two external components. Furthermore, the LP28012 is capable of operating from a USB power source.

Normal Charge Cycle

A charge cycle begins when the voltage at the V_{CC} pin rises above the UVLO threshold level and a 1% ISET ram resistor is connected from the ISET pin to ground or when a battery is connected to the charger output. If the BAT pin is less than 2.9V, the charger enters trickle charge mode. In this mode, the LP28012 supplies approximately 1/10 the ISET rammed charge current to bring the battery voltage up to a safe level for full current charging.

When the BAT pin voltage rises above 2.9V, the charger enters constant-current mode, where the ISET rammed charge current is supplied to the battery. When the BAT pin approaches the final float voltage, the LP28012 enters constant-voltage mode and the charge current begins to decrease. When the charge current drops to 1/10 of the ISET rammed value, the charge cycle ends.

ISET ramming Charge Current

The charge current is ISET rammed using a single resistor from the ISET pin to ground. The battery charge current is 500 times the current out of the ISET pin. The ISET ram resistor and the charge current are calculated using the following equations:

$$R_{SET}=1000V/ICHG , ICHG= 1000V/R_{SET}$$

The charge current out of the BAT pin can be determined at any time by monitoring the ISET pin voltage using the following equation:

$$I_{BAT}= V_{SET} \times 500/R_{SET}$$

Note: V_{SET} is 2Volts.

Charge Termination

A charge cycle is terminated when the charge current falls to

1/10th the ISET rammed value after the final float voltage is reached. This condition is detected by using an internal, filtered comparator to monitor the ISET pin. When the ISET pin voltage falls below 100mV for longer than t_{TERM} (typically 1ms), charging is terminated. The charge current is latched off and the LP28012 enters standby mode, where the input supply current drops to 200µA. (Note: C/10 termination is disabled in trickle charging and thermal limiting modes).

When charging, transient loads on the BAT pin can cause the ISET pin to fall below 200mV for short periods of time before the DC charge current has dropped to 1/10th the ISET rammed value. The 1ms filter time (t_{TERM}) on the termination comparator ensures that transient loads of this nature do not result in premature charge cycle termination. Once the average charge current drops below 1/10th the ISET rammed value, the LP28012 terminates the charge cycle and ceases to provide any current through the BAT pin. In this state, all loads on the BAT pin must be supplied by the battery.

The LP28012 constantly monitors the BAT pin voltage in standby mode. If this voltage drops below the 4.05V recharge threshold (V_{RESTAT}), another charge cycle begins and current is once again supplied to the battery. To manually restart a charge cycle when in standby mode, the input voltage must be removed and reapplied, or the charger must be shut down and restarted using the ISET pin.

Charge Status Indicator (STAT)

The charge status output has two different states: strong pull-down (~10mA) and high impedance. The strong pull-down state indicates that the LP28012 is in a charge cycle. Once the charge cycle has terminated, the pin state is determined by under voltage lockout conditions. High impedance indicates that the LP28012 is in under voltage lockout mode: either VCC is less than 100mV above the BAT pin voltage or insufficient voltage is applied to the VCC pin.

A microprocessor can be used to distinguish between these two states—this method is discussed in the Applications Information section.

Function	STAT2(pin3)	STAT1(pin2)
Charging	Low	High
Charge END	High	Low



Thermal Limiting

An internal thermal feedback loop reduces the I_{SET} rammmed charge current if the die temperature attempts to rise above a preset value of approximately 120°C. This feature protects the LP28012 from excessive temperature and allows the user to push the limits of the power handling capability of a given circuit board without risk of damaging the LP28012. The charge current can be set according to typical (not worst-case) ambient temperature with the assurance that the charger will automatically reduce the current in worst-case conditions. TDFN power considerations are discussed further in the Applications Information section.

Under voltage Lockout (UVLO)

An internal under voltage lockout circuit monitors the input voltage and keeps the charger in shutdown mode until V_{CC} rises above the under voltage lockout threshold. The UVLO circuit has a built-in hysteresis of 200mV. Furthermore, to protect against reverse current in the power MOSFET, the UVLO circuit keeps the charger in shutdown mode if V_{CC} falls to within 30mV of the battery voltage. If the UVLO comparator is tripped, the charger will not come out of shutdown mode until V_{CC} rises 100mV above the battery voltage.

Manual Shutdown

At any point in the charge cycle, the LP28012 can be put into shutdown mode by removing R_{ISET} thus floating the I_{SET} pin or V_{EN}=0V. This reduces the battery drain current and the supply current to less than 1µA. A new charge cycle can be initiated by reconnecting the I_{SET} ram resistor.

The STAT pin is in a high impedance state if the LP28012 is in under voltage lockout mode: either V_{CC} is within 100mV of the BAT pin voltage or insufficient voltage is applied to the V_{CC} pin. Once the charge cycle is terminated, the LP28012 continuously monitors the voltage on the BAT pin using a comparator with a 2ms filter time (t_{RECHARGE}). A charge cycle restarts when the battery voltage falls below 4.05V (which corresponds to approximately 80% to 90% battery capacity). This ensures that the battery is kept at or near a fully charged condition and eliminates the need for periodic charge cycle initiations. STAT output enters a strong pull-down state during recharge cycles.

Power Dissipation

The conditions that cause the LP28012 to reduce charge current through thermal feedback can be approximated by considering the power dissipated in the IC. Nearly all of this power dissipation is generated by the internal MOSFET—this is calculated to be approximately:

$$P_D = (V_{CC} - V_{BAT}) \cdot I_{BAT}$$

where PD is the power dissipated, VCC is the input supply voltage, VBAT is the battery voltage and IBAT is the charge current. The approximate ambient temperature at which the thermal feedback begins to protect the IC is:

$$T_A = 120^\circ\text{C} - P_D \theta_{JA}$$

$$T_A = 120^\circ\text{C} - (V_{CC} - V_{BAT}) \cdot I_{BAT} \cdot \theta_{JA}$$

Example: An LP28012 operating from a 5V USB supply is programmed to supply 400mA full-scale current to a discharged Li-Ion battery with a voltage of 3.75V. Assuming θ_{JA} is 46 °C /W (see Board Layout Considerations), the ambient temperature at which the LP28012 will begin to reduce the charge current is approximately:

$$T_A = 120^\circ\text{C} - (5\text{V} - 3.75\text{V}) \cdot (400\text{mA}) \cdot 46^\circ\text{C}/\text{W}$$

$$T_A = 120^\circ\text{C} - 0.5\text{W} \cdot 46^\circ\text{C}/\text{W} = 120^\circ\text{C} - 23^\circ\text{C}$$

$$T_A = 97^\circ\text{C}$$

The LP28012 can be used above 97°C ambient, but the charge current will be reduced from 400mA. The approximate current at a given ambient temperature can be approximated by:

$$I_{BAT} = \frac{120^\circ\text{C} - T_A}{(V_{CC} - V_{BAT}) \cdot \theta_{JA}}$$

Using the previous example with an ambient temperature of 60°C, the charge current will be reduced to approximately:

$$I_{BAT} = 1.04\text{A} @ V_{BAT} = 3.75\text{V}$$

Moreover, when thermal feedback reduces the charge current, the voltage at the PROG pin is also reduced proportionally as discussed in the Operation section. It is important to remember that LP28012 applications do not need to be designed for worst-case thermal conditions since the IC will automatically reduce power dissipation when the junction temperature reaches approximately 120°C.



Packaging Information

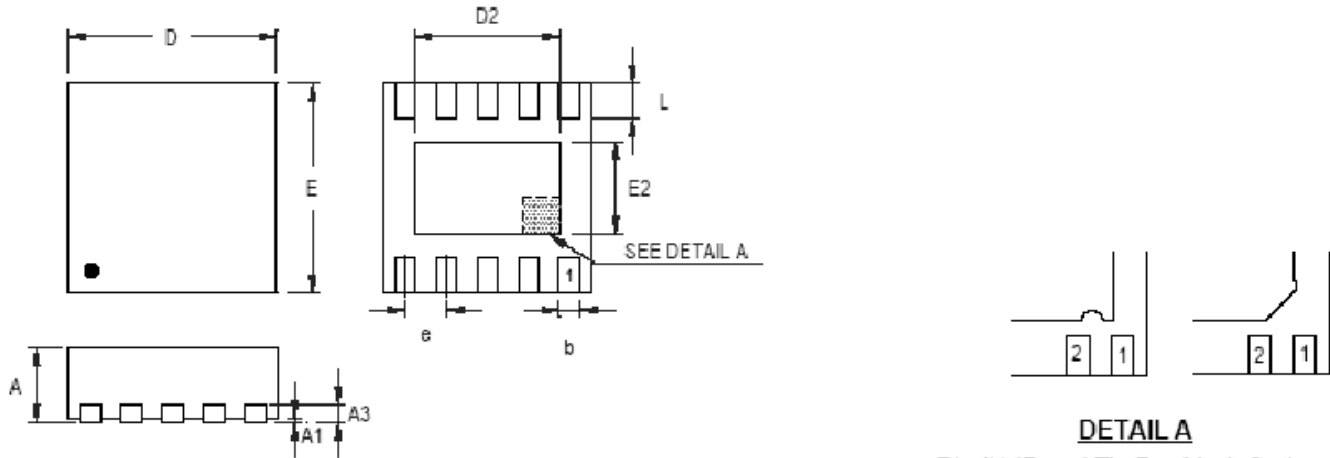

DETAIL A

Pin #1 ID and Tie Bar Mark Options

Note : The configuration of the Pin #1 identifier is optional, but must be located within the zone indicated.

Symbol	Dimensions In Millimeters		Dimensions In Inches	
	Min	Max	Min	Max
A	0.700	0.800	0.028	0.031
A1	0.000	0.050	0.000	0.002
A3	0.175	0.250	0.007	0.010
b	0.180	0.300	0.007	0.012
D	2.950	3.050	0.116	0.120
D2	2.300	2.650	0.091	0.104
E	2.950	3.050	0.116	0.120
E2	1.500	1.750	0.059	0.069
e	0.500		0.020	
L	0.350	0.450	0.014	0.018

W-Type 10L DFN 3x3 Package

单击下面可查看定价，库存，交付和生命周期等信息

[>>LOW POWER\(微源半导体\)](#)