



Filterless 3W Class- D Mono Audio Amplifier

General Description

The LPA2010 is a 3W, class-D audio amplifier. It offers low THD+N, allowing it to achieve high-quality Power Supply sound reproduction. The new filterless architecture allows the device to drive the speaker directly requiring no low-pass output filters, thus to save the system cost and PCB area. The LPA2010 is available in MSOP-8.

Order Information

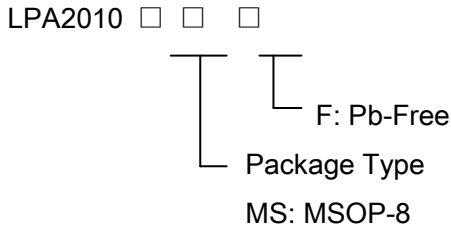

Applications

- ✧ Portable Bluetooth Speaker
- ✧ Cellular and Smart mobile phone
- ✧ Square Speaker

Features

- ◆ Shutdown current:<1uA
- ◆ 550KHz fixed frequency switching for amplifier
- ◆ 3W Output at 10% THD with a 4Ω Load and 5V VDD for amplifier
- ◆ 2.3W Output at 1% THD with a 4Ω Load and 5V VDD for amplifier
- ◆ Filterless, Low Quiescent Current and Low EMI
- ◆ Amplifier Efficiency up to 85%
- ◆ Free LC filter digital modulation, direct-drive speakers
- ◆ Short Circuit Protection
- ◆ Thermal Shutdown
- ◆ Few External Components to Save the Space and cost
- ◆ Pb-Free Package

Marking Information

Device	Marking	Package	Shipping
LPA2010	LPS LPA2010 YWX	MSOP-8	3K/REEL

Y: Y is year code. W: W is week code. X: X is series number.

Typical Application Circuit

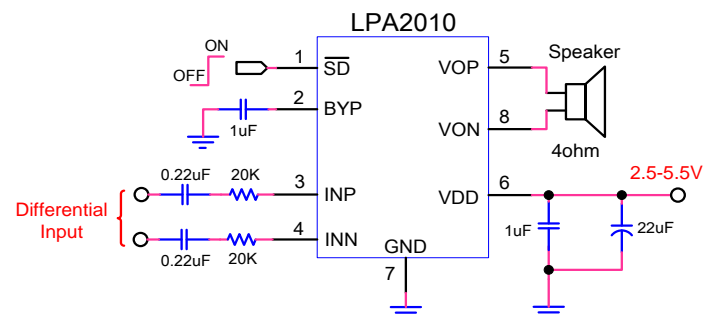



Functional Pin Description

MSOP-8/ Top View

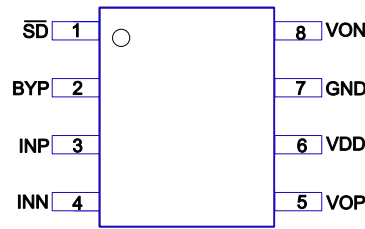

Functional Pin Description

Pin	PIN No.	DESCRIPTION
\overline{SD}	1	Shutdown pin. Active low.
BYP	2	Bypass pin. Connect a 1uF capacitor between this pin and GND.
INP	3	Positive input of amplifier.
INN	4	Negative input of amplifier.
VOP	5	Positive output of signal.
VDD	6	Voltage supply pin.
GND	7	Ground pin.
VON	8	Negative output of signal.

Absolute Maximum Ratings ^{Note 1}

- ◇ VDD Voltage to GND ----- -0.3V to 6.0V
- ◇ Other pin Voltage to GND ----- -0.3V to 5.5V
- ◇ Maximum Junction Temperature ----- 125°C
- ◇ Operating Ambient Temperature Range (Ta) ----- -40°C to 85°C
- ◇ Maximum Soldering Temperature (at leads, 10 sec) ----- 260°C

Note 1. Stresses beyond those listed under “Absolute Maximum Ratings” may cause permanent damage to the device. These are stress ratings only, and functional operation of the device at these or any other conditions beyond those indicated in the operational sections of the specifications is not implied. Exposure to absolute maximum rating conditions for extended periods may affect device reliability.

Thermal Information

- ◇ Maximum Power Dissipation (PD, TA=25°C) ----- 1.0W
- ◇ Thermal Resistance (JA) ----- 120°C/W

ESD Susceptibility

- ◇ HBM(Human Body Mode) ^{Note 2} ----- 2KV
- ◇ MM(Machine Mode) ^{Note 3} ----- 200V

Note 2. The Human body model (HBM) is a 100pF capacitor discharged through a 1.5kΩ resistor into each pin. The testing is done according JEDEC.

Note 3. Machine Model (MM) is a 200pF capacitor discharged through a 500nH inductor with no series resistor into each pin. The testing is done according JEDEC.



Electrical Characteristics For Amplifier

(VDD = 5V, RL=4Ω, TA = 25° C, unless otherwise specified)

Parameter	Symbol	Test Conditions	Min	Typ	Max	Units
Supply power	VDD		2.5		5.5	V
Output power	Po	THD+N=10%, f=1KHz,RL=4Ω	VDD=5.0V	3		W
			VDD=4.2V	2		
			VDD=3.7V	1.58		
		THD+N=1%, f=1KHz,RL=4Ω	VDD=5.0V	2.3		
			VDD=4.2V	1.6		
			VDD=3.7V	1.28		
		THD+N=10%, f=1KHz,RL=8Ω	VDD=5.0V	1.73		
			VDD=4.2V	1.2		
			VDD=3.7V	0.92		
		THD+N=1%, f=1KHz,RL=8Ω	VDD=5.0V	1.42		
			VDD=4.2V	0.98		
			VDD=3.7V	0.75		
Power supply ripple rejection	PSRR	INPUT ac-grounded with CIN=0.47uF, VDD=5.0V	f=100HZ	75		dB
			f=1KHz	50		
Signal-to-noise ratio	SNR	VDD=5V, RL=4Ω, THD=1%	f=1KHz	88		dB
frequency switching	Fsw	VDD=5V		550		KHz
Output noise	V _N	INPUT ac-grounded with CIN=0.47uF, VDD=5.0V		140		μV
V _{OS}		VDD=5.0V, V _{SD} =0V		5		mV
Shutdown current	I _{LEAK}	V _{SD} =VDD=5.0V		0.1		uA
Quiescent current	I _Q	VDD=5.0V, No load		2		mA
High-level input voltage	V _{SD_H}	VDD=5.0V	1			V
Low-level input voltage	V _{SD_L}	VDD=5.0V			0.4	V



Test setup for graphs

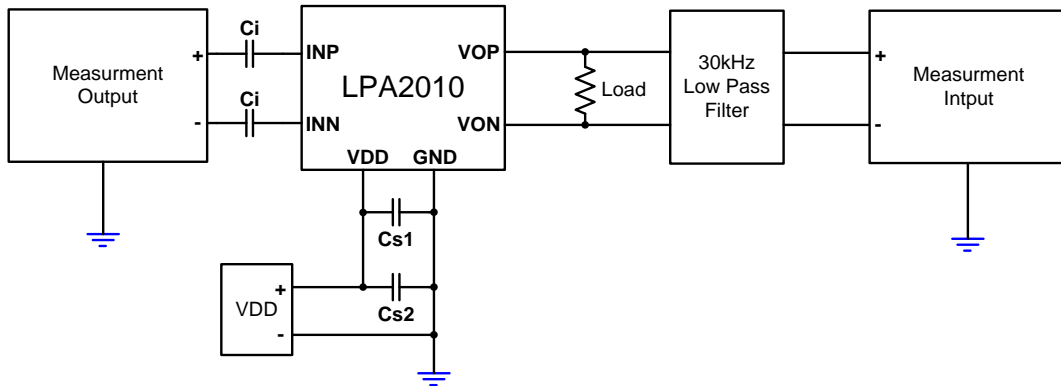

1. Ci was shorted for any common-mode input voltage measurement. All other measurements were taken with Ci = 0.1µF (unless otherwise noted).
2. Cs1 = 0.1 µF is placed very close to the device. The optional Cs2 = 10 µF is used for datasheet graphs.
3. The 30 kHz low-pass filter is required even if the analyzer has an internal low-pass filter. An RC low-pass filter (1 kΩ, 4700pF) is used on each output for the data sheet graphs.

Typical Operating Characteristic

PO VS THD

Audio Precision

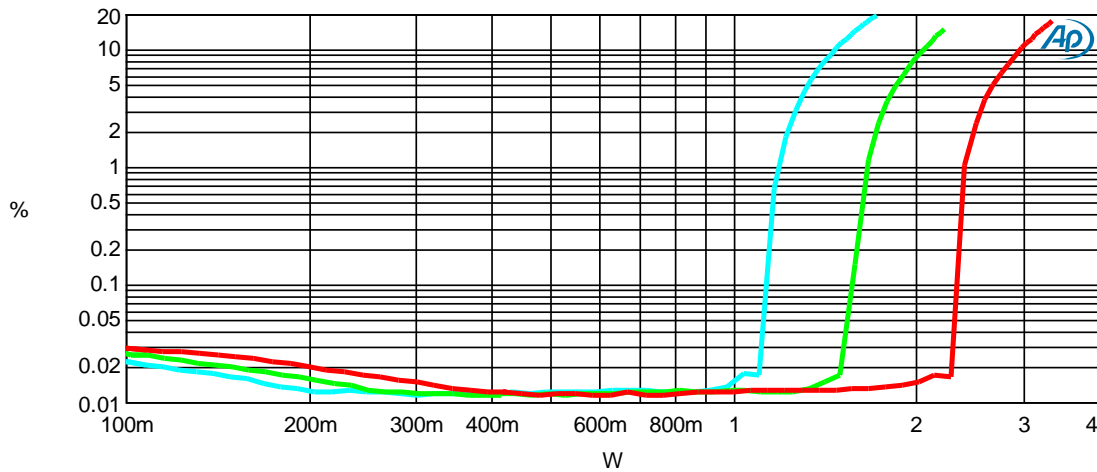

Sweep	Trace	Color	Line Style	Thick	Data	Axis	Comment
1	1	Cyan	Solid	3	Analyzer.TH+D+N Ratio A	Left	3.6V,4ohm
2	1	Green	Solid	3	Analyzer.TH+D+N Ratio A	Left	4.2V,4ohm
3	1	Red	Solid	3	Analyzer.TH+D+N Ratio A	Left	5V,4ohm

PO VS THD@4ohm.ats2



Audio Precision

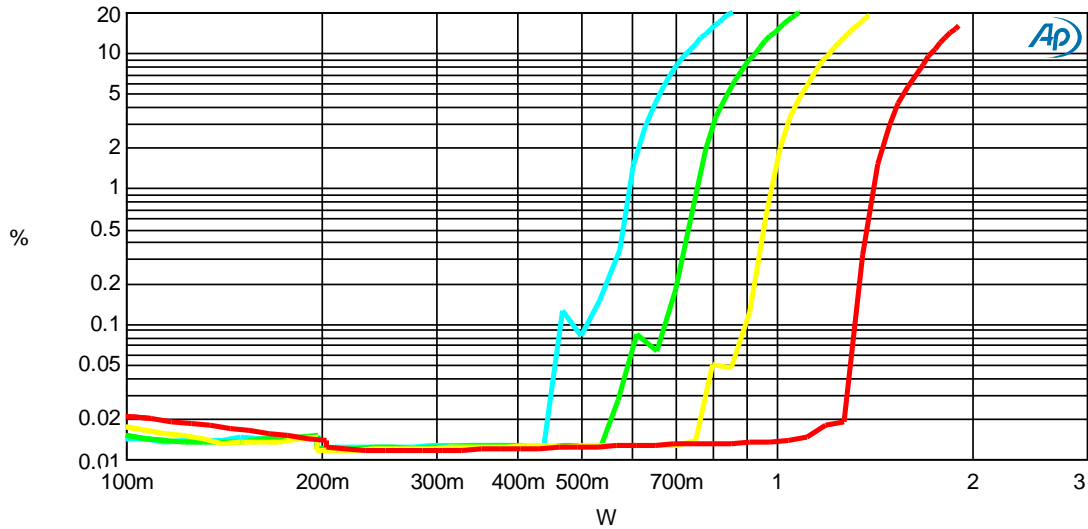

Sweep	Trace	Color	Line Style	Thick	Data	Axis	Comment
1	1	Cyan	Solid	3	Analyzer.THD+N Ratio A	Left	3.3V,8ohm
2	1	Green	Solid	3	Analyzer.THD+N Ratio A	Left	3.7V,8ohm
3	1	Yellow	Solid	3	Analyzer.THD+N Ratio A	Left	4.2V,8ohm
4	1	Red	Solid	3	Analyzer.THD+N Ratio A	Left	5V,8ohm

PO VS THD@8ohm.ats2

Frequency response curve

Audio Precision

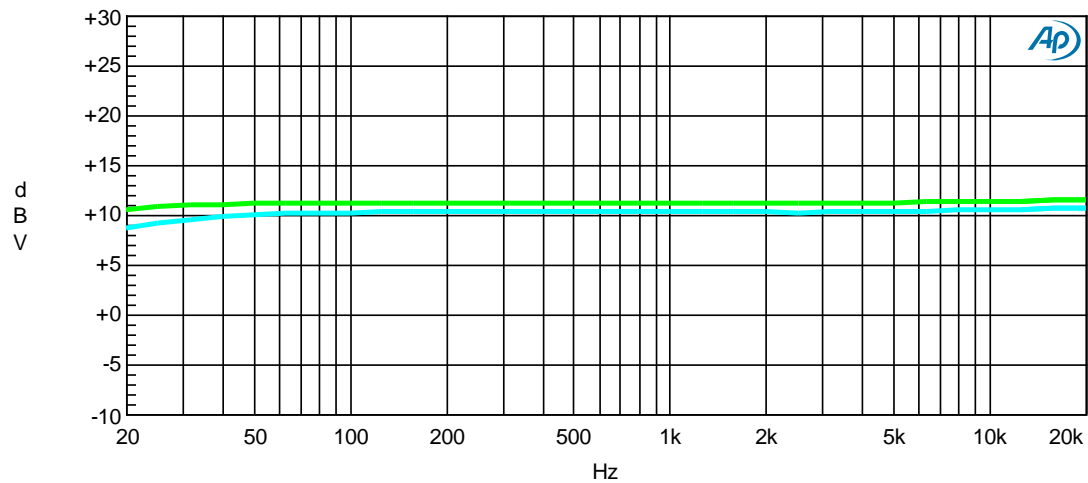

Sweep	Trace	Color	Line Style	Thick	Data	Axis	Comment
1	1	Cyan	Solid	3	Analyzer.Level A	Left	5V,4ohm,D,1%
2	1	Green	Solid	3	Analyzer.Level A	Left	5V,4ohm,D,10%



Frequency VS THD

Audio Precision

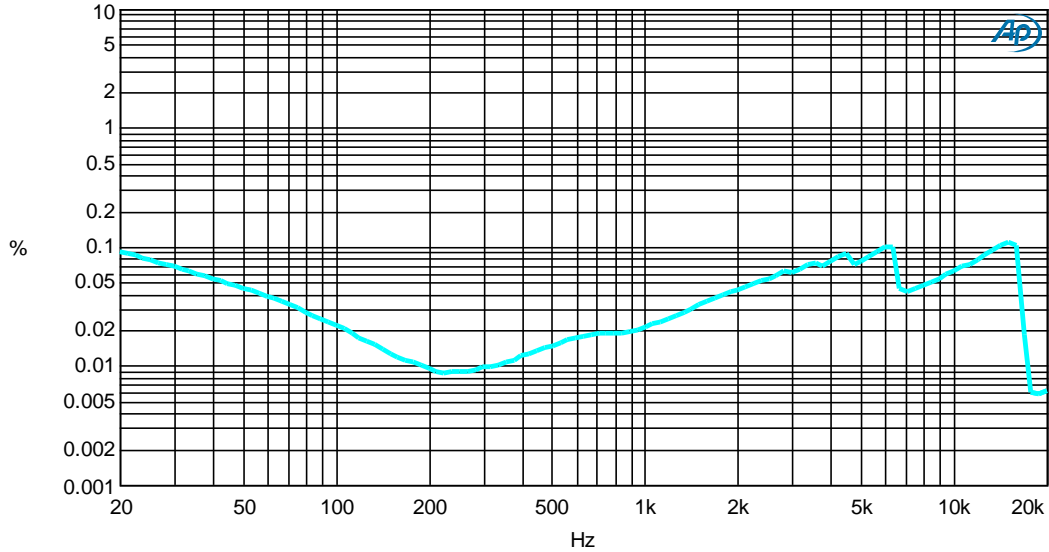

Sweep	Trace	Color	Line Style	Thick	Data	Axis	Comment
1	1	Cyan	Solid	3	Analyzer.THD+N Ratio A	Left	5V, 4ohm, 1W

Applications Information

Maximum Gain

The LPA2010 has two internal amplifier stages. The first stage's gain is externally configurable, while the second stage's is internally fixed. The closed-loop gain of the first stage is set by selecting the ratio of Rf to Ri while the second stage's gain is fixed at 2x. The output of amplifier 1 serves as the input to amplifier 2, thus the two amplifiers produce signals identical in magnitude, but different in phase by 180°. Consequently, the differential gain for the IC is

$$A_{VD} = 20 \cdot \log [2 \cdot R_f / (R_i + 6)]$$

The LPA2010 sets maximum:

$$R_f = 150 \text{ k}\Omega \pm 10\%$$

Shutdown operation

In order to reduce power consumption while not in

use, the LPA2010 contains shutdown circuitry to turn off the amplifier's bias circuitry. This shutdown feature turns the amplifier off when logic low is applied to the SD pin. By switching the SD pin connected to GND, the LPA2010 supply current draw will be minimized in idle mode.

Power supply decoupling

The LPA2010 is a high performance CMOS audio amplifier that requires adequate power supply decoupling to ensure the output THD and PSRR a low as possible. Power supply decoupling affects low frequency response. Optimum decoupling is achieved by using two capacitors of different types targeting to different types of noise on the power supply leads. For higher frequency transients, spikes, or digital hash on the line, a good low equivalent-series-resistance (ESR) ceramic capacitor, typically 1.0uF, works best, placing it as



close as possible to the device VDD terminal. For filtering lower- frequency noise signals, a large capacitor of 22uF (ceramic) or greater is recommended, placing it near the audio power amplifier.

Input Capacitor (C_i)

C_i for boost. Large input capacitors are both expensive and space hungry for portable designs. Clearly, a certain sized capacitor is needed to couple in low frequencies without severe attenuation. But in many cases the speakers used in portable systems, whether internal or external, have little ability to reproduce signals below 100Hz to 150Hz. In the typical application, an input capacitor C_i is required to allow the amplifier to bias the input signal to the proper dc level for optimum operation. Thus, using a large input capacitor may not increase actual system performance. In this case, input capacitor (C_i) and input resistance (R_i) of the amplifier form a high-pass filter with the corner frequency determined by equation below,

$$f_c = \frac{1}{2\pi R_i C_i}$$

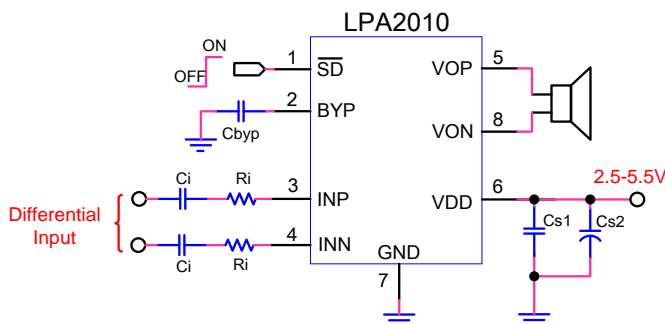

LPA2010 Application Schematic With Differential Input

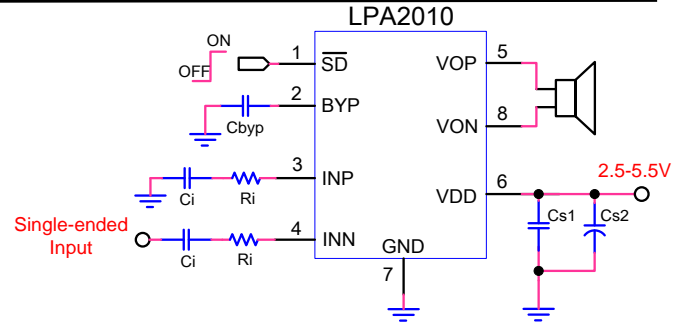

LPA2010 Application Schematic With Single-Ended Input

Analog Reference Bypass Capacitor (CBYP)

In addition to system cost and size, click and pop performance is affected by the size of the input coupling capacitor, C_i. A larger input coupling capacitor requires more charge to reach its quiescent DC voltage (nominally 1/2 VDD). This charge comes from the internal circuit via the feedback and is apt to create pops upon device enable. Thus, by minimizing the capacitor size based on necessary low frequency response, turn-on pops can be minimized.

The Analog Reference Bypass Capacitor (CBYP) is the most critical capacitor and serves several important functions. During start-up or recovery from shutdown mode, CBYP determines the rate at which the amplifier starts up. The second function is to reduce noise caused by the power supply coupling into the output drive signal. This noise is from the internal analog reference to the amplifier, which appears as degraded PSRR and THD+N. The LPA2010 incorporates circuitry designed to detect low supply voltage. When the supply voltage drops to 2.5V or below, the LPA2010 outputs are disabled, and the device comes out of this state and starts to normal function when VDD ≥ 2.5V.

Short Circuit Protection (SCP)

The LPA2010 has short circuit protection circuitry on the outputs to prevent damage to the device when output-to-output or output-to-GND short occurs. When a short circuit is detected on the outputs, the



outputs are disabled immediately. If the short was removed, the device activates again.

Over Temperature Protection

Thermal protection on the LPA2010 prevents the device from damage when the internal die temperature exceeds 140°C. There is a 15 degree tolerance on this trip point from device to device. Once the die temperature exceeds the thermal set point, the device outputs are disabled. This is not a latched fault. The thermal fault is cleared once the temperature of the die is reduced by 30°C. This large hysteresis will prevent motor boating sound well and the device begins normal operation at this point without external system intervention.

When to use an output filter

Design the LPA2010 without an Inductor / Capacitor (LC) output filter if the traces from the amplifier to the speaker are short. Wireless handsets and PDAs are great applications for this class-D amplifier to be used without an output filter.

The LPA2010 does not require an LC output filter for short speaker connections (approximately 100 mm long or less). A ferrite bead can often be used in the design if failing radiated emissions testing without an LC filter; and, the frequency-sensitive circuit is greater than 1MHz. If choosing a ferrite bead, choose one with high impedance at high frequencies, but very low impedance at low frequencies. The selection must also take into account the currents flowing through the ferrite bead. Ferrites can begin to lose effectiveness at much lower than rated current values.

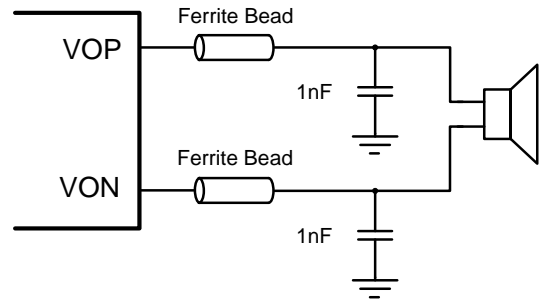

Typical ferrite-bead output filter

PCB Layout notices

- 1, In the path of the input signal plus a 103-to-ground high-frequency filter capacitor.
- 2, The power and ground and filter capacitor and bypass capacitors as close to the chip's pins, remember not to put the capacitor on the back of the board, through tiny holes through the jumper even over.
- 3, Power, ground, and a large current signal line to go to try to rough, if you want to add vias, the number of through-holes must be at least 6.
- 4, If you want to pursue as large as the effect of power, a large selection of speakers or sound chamber with low resistance (such as 3.6Ω) speakers, or added to improve the supply voltage boost circuit.
- 5, Sensitive attention to shielding the signal line, it is best to use a differential signal. Try not to interfere with the sensitive line through the signal line.
- 6, The position on the board under the amplifier chip must be added vents and large areas of exposed copper and tin to enhance heat dissipation.



Packaging Information

MSOP8

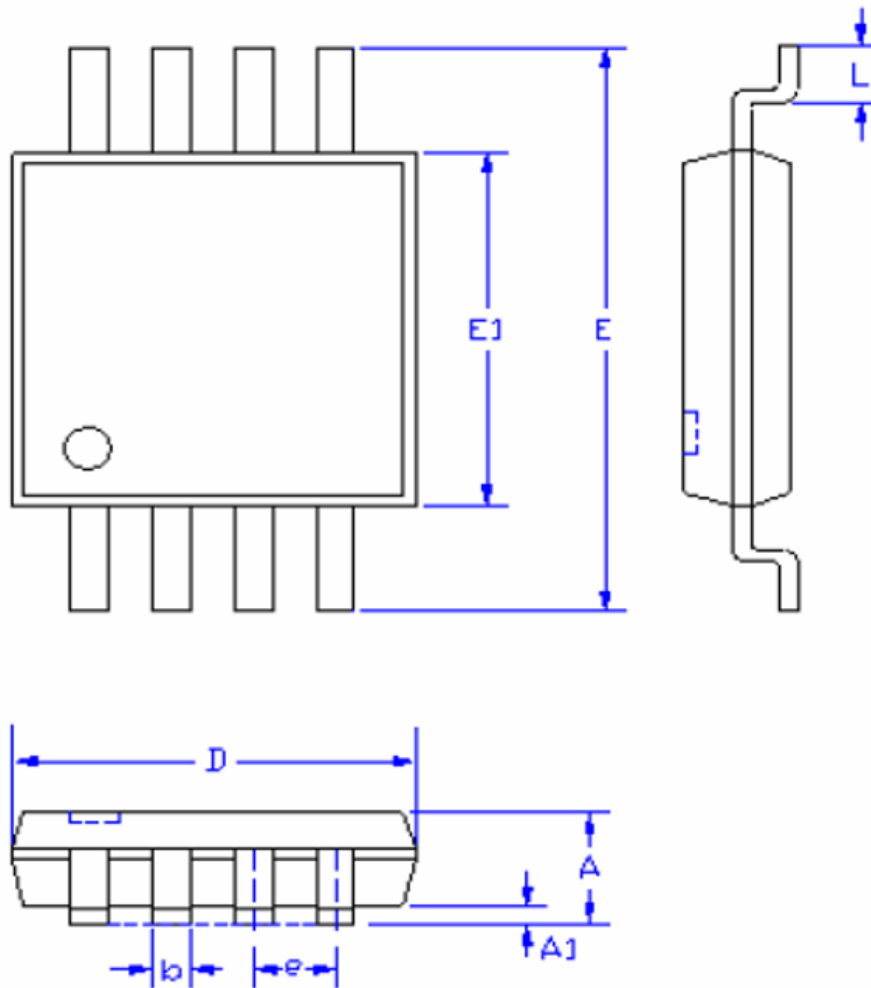

SYMBOLS	MILLIMETERS		INCHES	
	MIN.	MAX.	MIN.	MAX.
A	-	1.10	-	0.043
A1	0.00	0.15	0.000	0.006
D	3.00		0.118	
E1	3.00		0.118	
E	4.70	5.10	0.185	0.201
L	0.40	0.80	0.016	0.031
b	0.22	0.38	0.008	0.015
e	0.65		0.026	

单击下面可查看定价，库存，交付和生命周期等信息

[>>LOW POWER\(微源半导体\)](#)