



## 600mA, Ultra-low Noise LDO Regulator

### General Description

The LP3986H is designed for portable applications with demanding performance and space requirements. The LP3986H performance is optimized for battery-powered systems to deliver ultra low noise and low quiescent current. Regulator ground current increases only slightly in dropout, further prolonging the battery life. The LP3986H also works with low-ESR ceramic capacitors, reducing the amount of board space necessary for power applications, critical in hand-held wireless devices. The other features include ultra low dropout voltage, high output accuracy, current limiting protection, and high ripple rejection ratio. Available in the 3-lead of SOT-23 and SOT-89 packages.

### Features

- ◆ Ultra-Low-Noise for RF Application
- ◆ 2.5V- 6.5V Input Voltage Range
- ◆ Low Dropout : 480mV @ 600mA
- ◆ Ultra-Fast Response in Line/Load Transient
- ◆ Current Limiting and Thermal Shutdown Protection

### Applications

- ◇ PMP/PDA/MP3 players
- ◇ Cellular and Mobile phone
- ◇ RF Module
- ◇ Sensor Module

### Order Information

LP3986H	□	□	□	□	□
	F: Pb-Free				
	Package Type				
	B3: SOT23-3				
	X3: SOT-89				
	Output Type				
	12:	1.2V			
	15:	1.5V			
	18:	1.8V			
	25:	2.5V			
	28:	2.8V			
	30:	3.0V			
	33:	3.3V			
	50:	5.0V			

### Typical Application Circuit

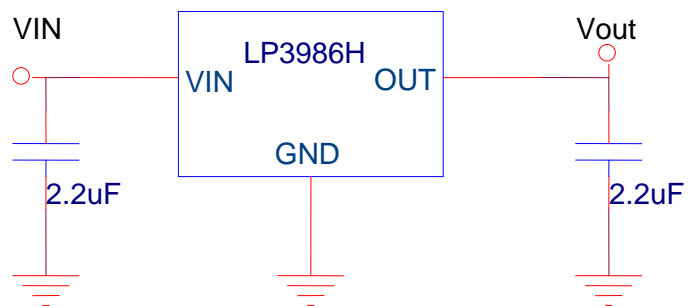

### Marking Information

Device	Marking	Package	Shipping
LP3986HB3F		SOT23-3	3K/REEL
LP3986HX3F		SOT89	1K/REEL



### Functional Pin Description

Package Type	Pin Configurations
SOT23-3 / SOT-89	

### Pin Description

Pin		Name	Description
SOT-89	SOT23-5		
1	1	GND	Ground.
2	3	VIN	Power Input Pin.
3	2	OUT	Output Pin.

### Function Diagram

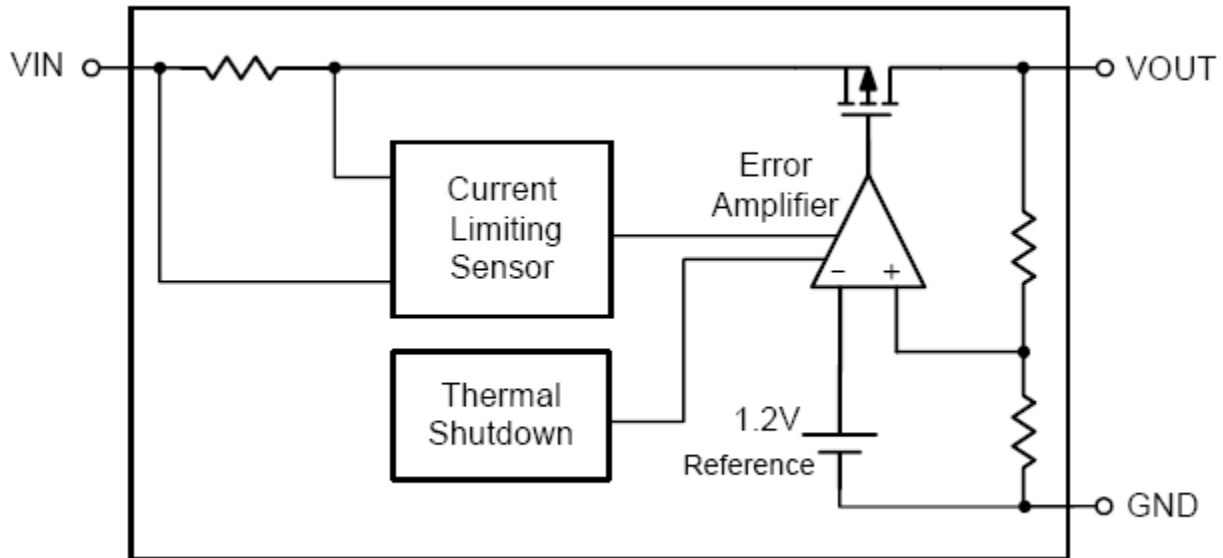



## Absolute Maximum Ratings

- ◇ Supply Input Voltage ----- 7V  
Power Dissipation, PD @ TA = 25°C
- ◇ SOT-23 ----- 450mW
- ◇ SOT-89 ----- 700mW
- Package Thermal Resistance
- ◇ SOT-23,  $\theta_{JA}$  ----- 250°C/W
- ◇ SOT-89,  $\theta_{JA}$  ----- 165°C/W
- ◇ Lead Temperature (Soldering, 10 sec.) ----- 260°C
- ◇ Storage Temperature Range ----- -65°C to 165°C
- ESD Susceptibility
- ◇ HBM (Human Body Mode) ----- 2kV
- ◇ MM(Machine-Mode) ----- 200V
- Recommended Operating Conditions
- ◇ Supply Input Voltage ----- 2.5V to 6V
- ◇ Operation Junction Temperature Range ----- -40°C to 125°C
- ◇ Operation Ambient Temperature Range ----- -40°C to 85°C

## Electrical Characteristics

(VIN = VOUT + 1V, CIN = COUT = 2.2μF, TA = 25° C, unless otherwise specified)

Parameter	Symbol	Test Conditions	Min	Typ.	Max	Units
Output Voltage Accuracy	$\Delta V_{OUT}/V_{OUT}$	$I_{OUT} = 1mA$	-3	--	+3	%
Current Limit	$I_{LIM}$	$R_{LOAD} = 1\Omega$	650			mA
Quiescent Current	$I_Q$	$I_{OUT} = 0mA$		90		μA
Dropout Voltage	$V_{DROP}$	$I_{OUT} = 600mA, V_{OUT} > 2.8V$		480		mV
Line Regulation	$\Delta V_{OUT}/V_{OUT}$	$V_{IN} = (V_{OUT} + 1V) \text{ to } 5.5V,$ $I_{OUT} = 1mA$			0.2	%
Load Regulation	$\Delta V_{LOAD}$	$1mA < I_{OUT} < 300mA$			2	%
Thermal Shutdown Temperature	$T_{SD}$			150		°C
Thermal Shutdown Hysteresis				20		°C



## Typical Operating Characteristics

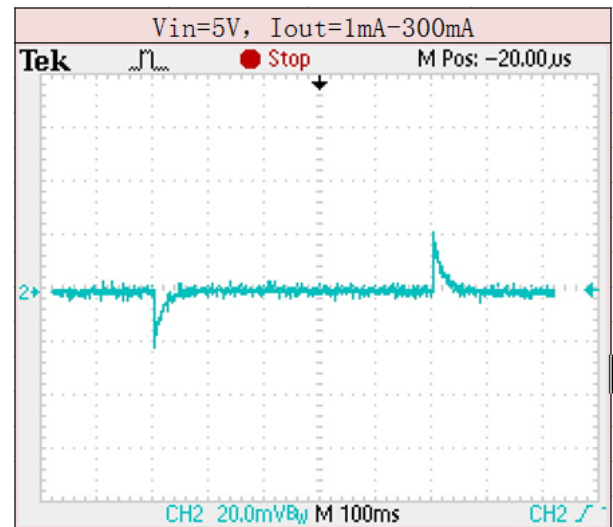
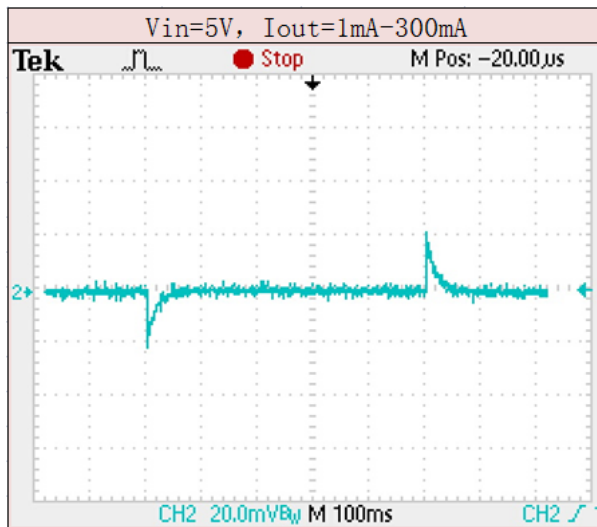
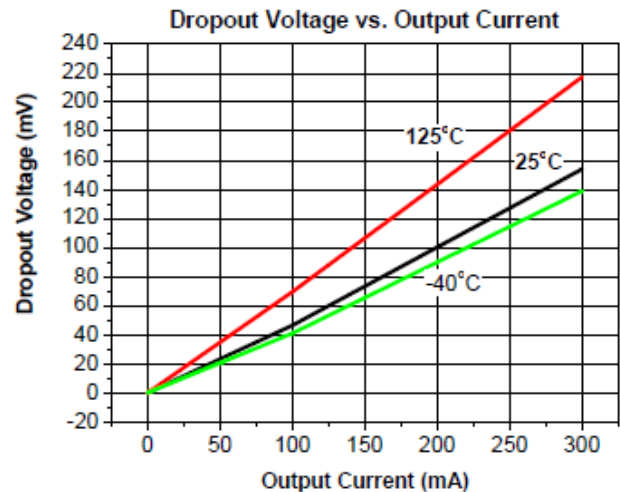
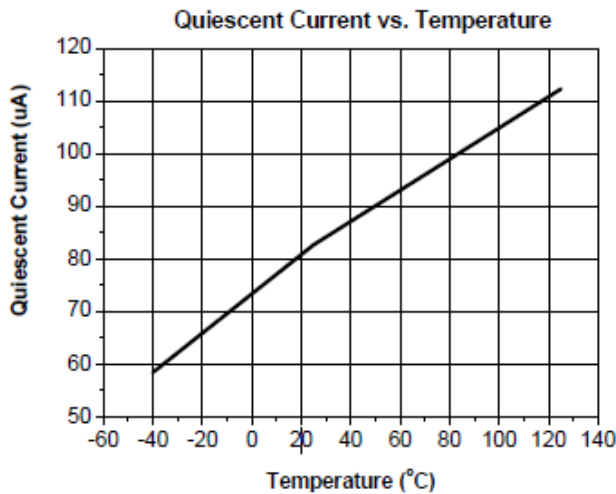
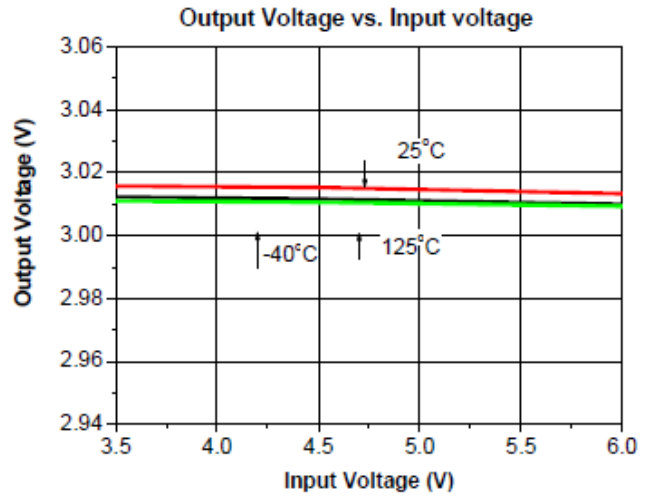
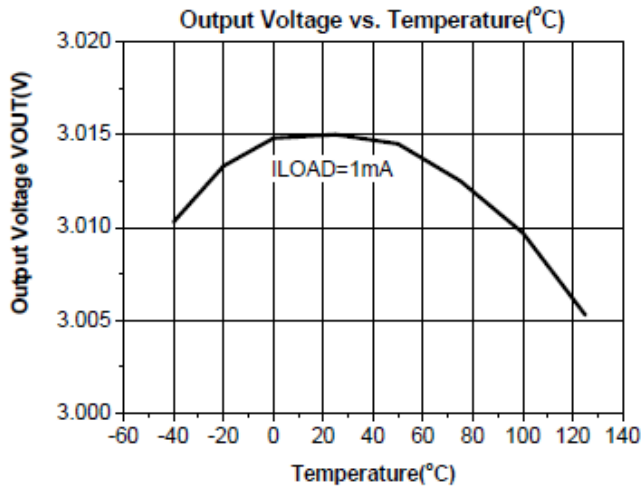



### Packaging Information

#### SOT-89-3

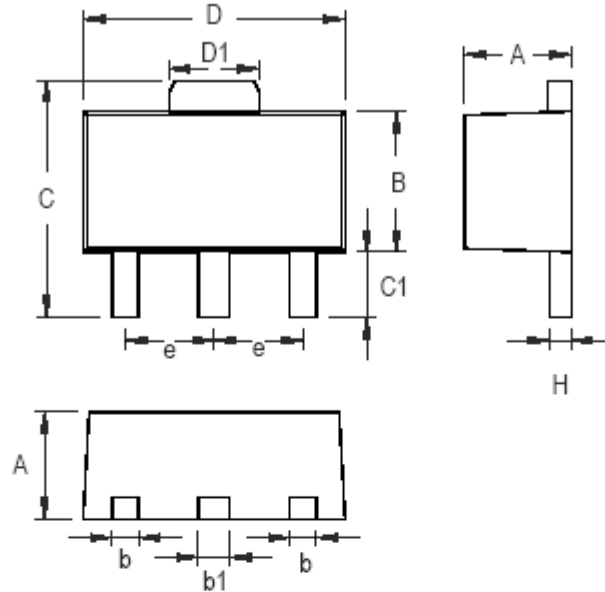

Symbol	Dimensions In Millimeters		Dimensions In Inches	
	Min	Max	Min	Max
A	1.397	1.600	0.055	0.063
b	0.356	0.483	0.014	0.019
B	2.388	2.591	0.094	0.102
b1	0.406	0.533	0.016	0.021
C	3.937	4.242	0.155	0.167
C1	0.787	1.194	0.031	0.047
D	4.394	4.597	0.173	0.181
D1	1.397	1.753	0.055	0.069
e	1.448	1.549	0.057	0.061
H	0.356	0.432	0.014	0.017

3-Lead SOT-89 Surface Mount Package



SOT23-3

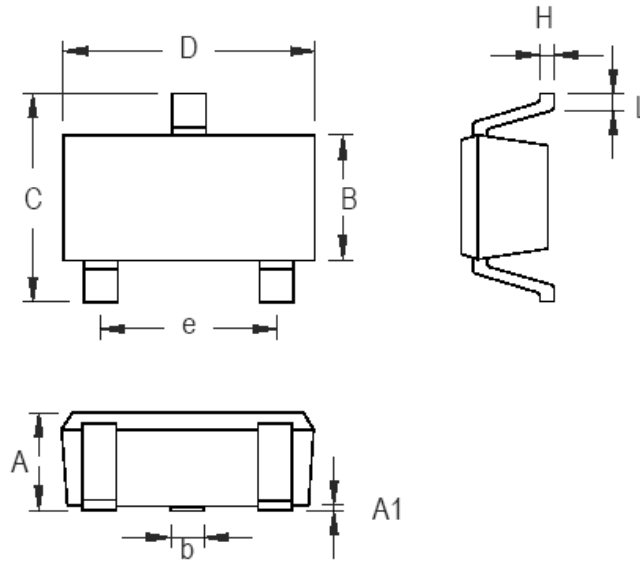

Symbol	Dimensions In Millimeters		Dimensions In Inches	
	Min	Max	Min	Max
A	0.889	1.295	0.035	0.051
A1	0.000	0.152	0.000	0.006
B	1.397	1.803	0.055	0.071
b	0.356	0.508	0.014	0.020
C	2.591	2.997	0.102	0.118
D	2.692	3.099	0.106	0.122
e	1.803	2.007	0.071	0.079
H	0.080	0.254	0.003	0.010
L	0.300	0.610	0.012	0.024

SOT-23 Surface Mount Package

单击下面可查看定价，库存，交付和生命周期等信息

[>>LOW POWER\(微源半导体\)](#)