



High Performance Regulated Charge Pump

General Description

The LP3110 is a high performance charge pump DC/DC converter that produces a regulated 5V output. No external inductor is required for operation. The operating voltage range is 2.8V to V_{OUT} . Internal soft-start circuitry effectively reduces the in-rush current both while start-up and mode change.

The LP3110 features very low quiescent current, over current protection and short circuit protection.

The LP3110 is available in SOT23-6 package.

Features

- ◆ 2x Mode for Ultra-High Efficiency
- ◆ 2.8V to V_{OUT} Range Input Voltage
- ◆ Soft Start Function
- ◆ Built-In Short-Circuit Protection
- ◆ 340KHz Fixed frequency
- ◆ Built-in Thermal Protection
- ◆ Over Current Protection Function
- ◆ $I_{SD} < 1\mu A$ in Shutdown
- ◆ SOT23-6 Package
- ◆ RoHS Compliant and 100% Lead (Pb)-Free

Order Information

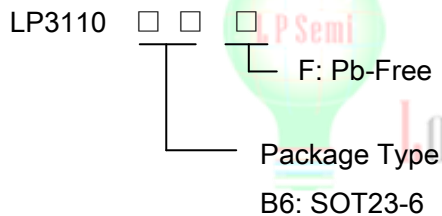

Applications

- ◇ LCD Panel
- ◇ Cellular and Smart mobile phone
- ◇ PDA/DSC
- ◇ Flash LED Driver

Typical Application Circuit

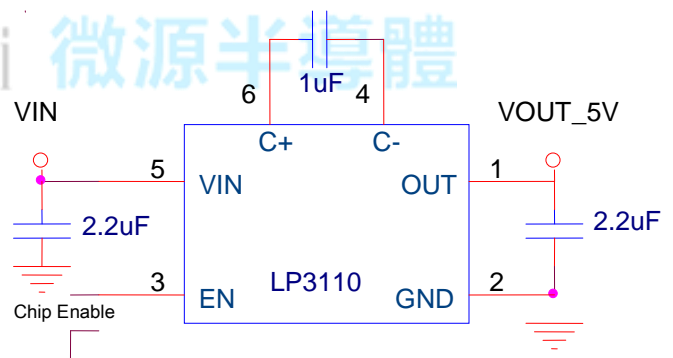

Marking Information

Device	Marking	Package	Shipping
LP3110	LPS D3XXX	SOT23-6	3K/REEL
X : Batch numbers.			

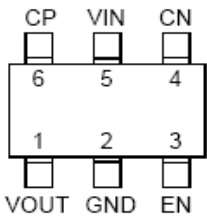

Functional Pin Description

Package Type		Pin Configurations
SOT23-6		(TOP VIEW) 
Pin	Name	Description
1	VOUT	Output Voltage.
2	GND	Ground.
3	EN	Chip Enable (Active High).
4	CN	Flying Capacitor Negative Terminal.
5	VIN	Power Input Voltage.
6	CP	Flying Capacitor Positive Terminal.

Function Block Diagram

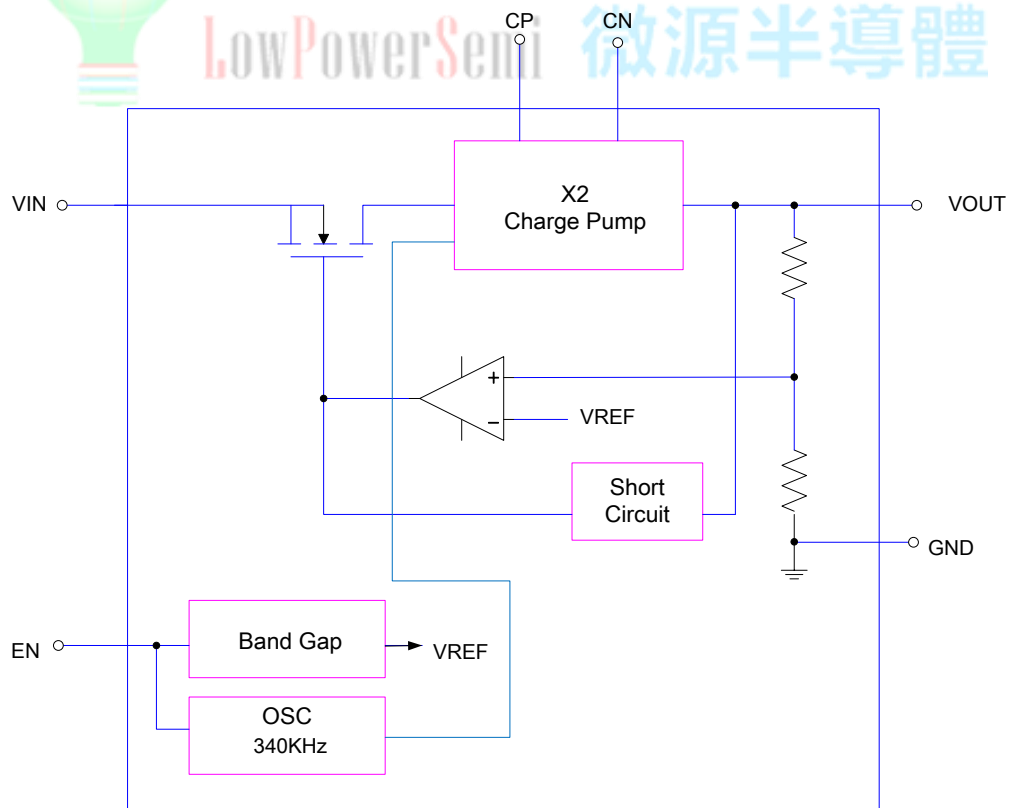



Absolute Maximum Ratings ^{Note 1}

- ✧ Input Voltage to GND (V_{IN}) ----- 5.5V
- ✧ EN to GND Voltage (V_{EN}) ----- 0.3V to $V_{IN}+0.3V$
- ✧ Maximum Power Dissipation (P_D) ----- 0.45W
- ✧ Thermal Resistance (J_A) ----- 250°C/W
- ✧ Operating Junction Temperature Range ----- 125°C
- ✧ Operation Ambient Temperature Range ----- 20°C to 85°C
- ✧ Maximum Soldering Temperature (at leads, 10sec) ----- 260°C

Note 1. Stresses beyond those listed under “Absolute Maximum Ratings” may cause permanent damage to the device. These are stress ratings only, and functional operation of the device at these or any other conditions beyond those indicated in the operational sections of the specifications is not implied. Exposure to absolute maximum rating conditions for extended periods may affect device reliability.

ESD Susceptibility

- ✧ HBM(Human Body Mode) ----- 2KV
- ✧ MM(Machine Mode) ----- 200V

Electrical Characteristics

(Over recommended operating conditions unless specified otherwise, $V_{IN}=3.6V, EN=High, TA=25^\circ C$)

Parameter	Symbol	Condition	Min	Typ	Max	Units
Input Voltage	V_{IN}		2.8		V_{OUT}	V
Output Voltage Range	V_{OUT}			5		V
Quiescent Current	I_Q	No Load		2		mA
Shutdown Current	I_{SHDN}	$V_{EN} = GND$		1	5	μA
Oscillator Frequency	f_{OSC}			340		KHz
Output Short Circuit Current Limit	I_{SC}	$V_{OUT} < 0.5V$	300	350		mA
Enable Threshold Low	$V_{EN(L)}$				0.4	V
Enable Threshold High	$V_{EN(H)}$		1.4			V
Input Low Current	I_{EN}	$V_{IN} = V_{EN} = 5.5V$		1		μA



Typical Operating Characteristics

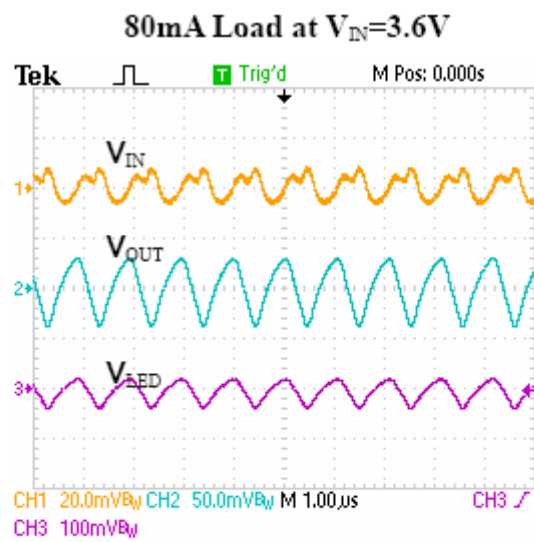
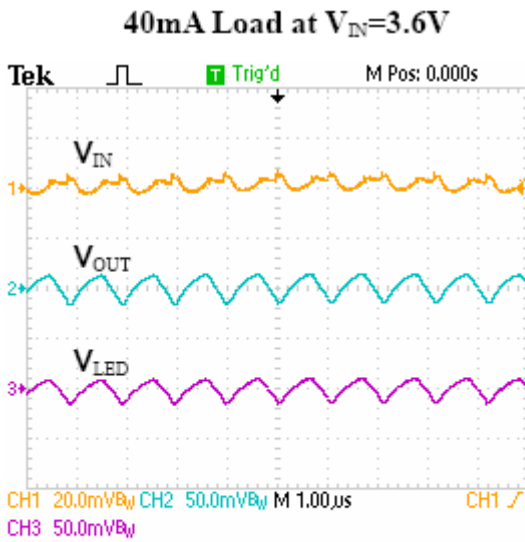
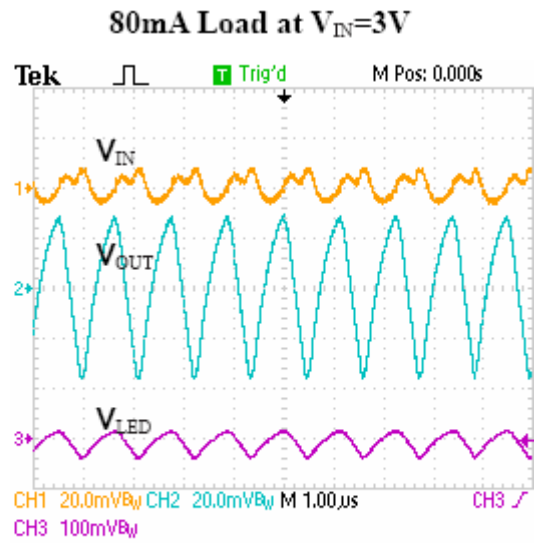
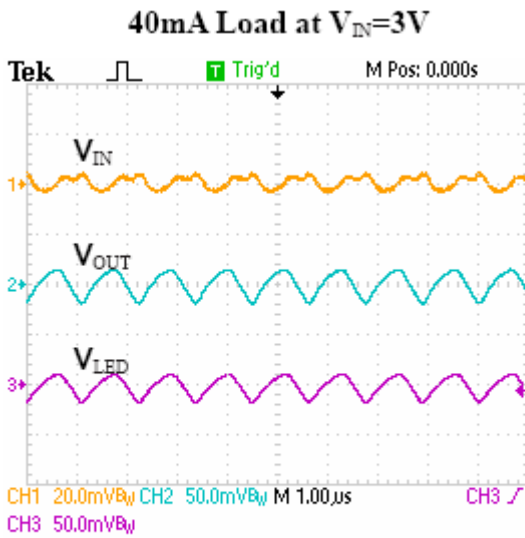



Application Information

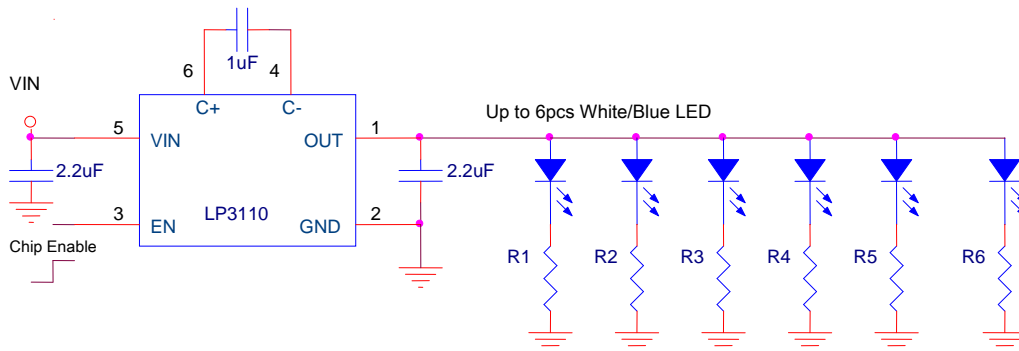

Figure1: Up to 6pcs White/Blue LED Driver from Li-Ion Battery Source

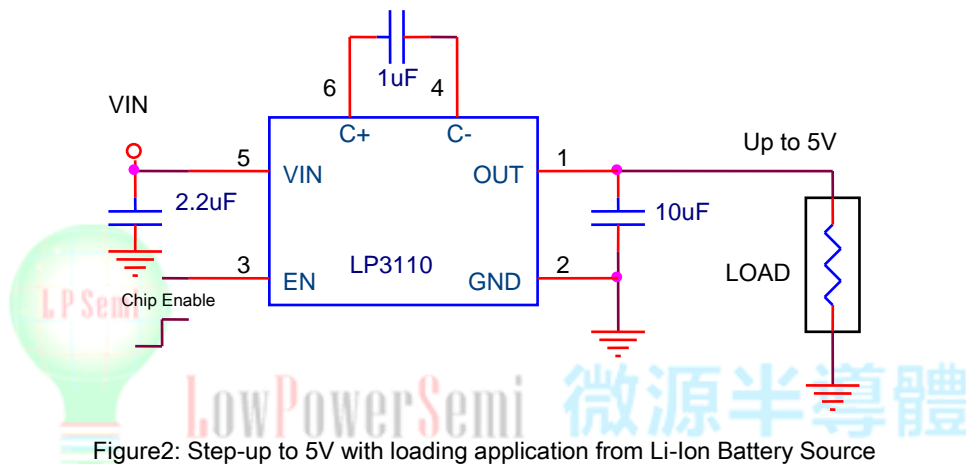

Figure2: Step-up to 5V with loading application from Li-Ion Battery Source

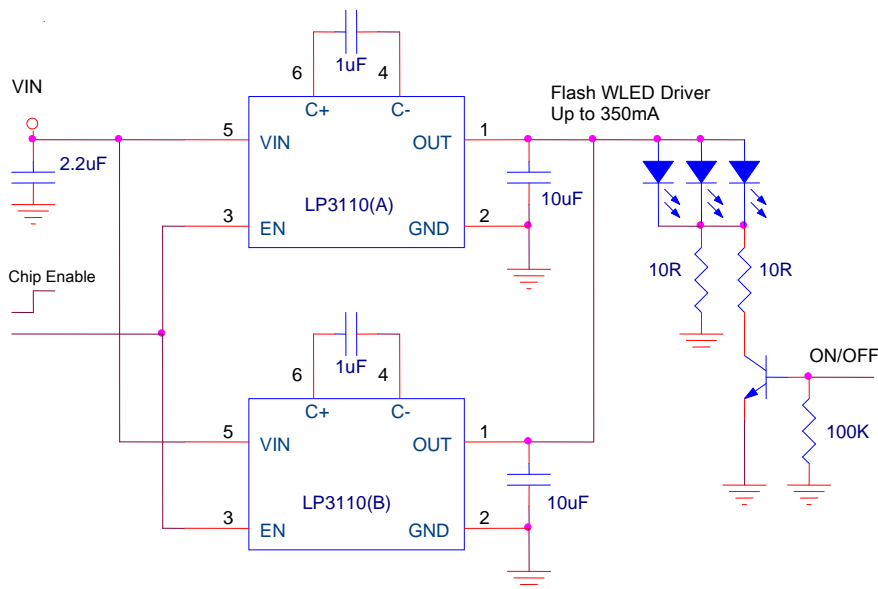
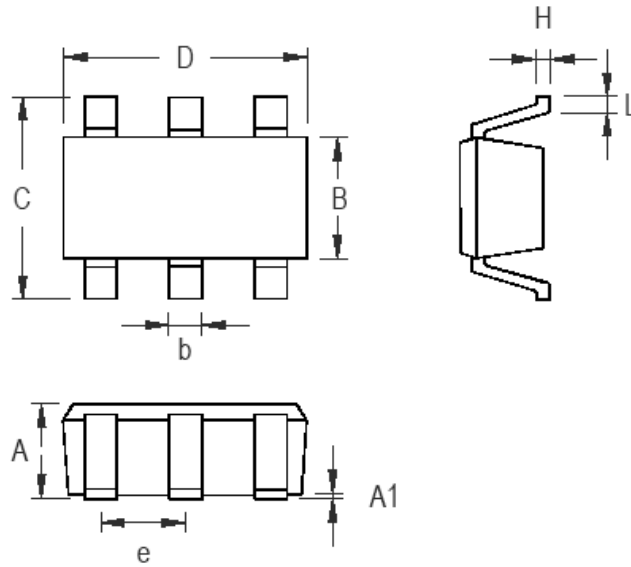

Figure3: Large Current Flash LED Driver from Li-Ion Battery Source



Packaging Information

SOT23-6 Package



Symbol	Dimensions In Millimeters		Dimensions In Inches	
	Min	Max	Min	Max
A	0.889	1.295	0.031	0.051
A1	0.000	0.152	0.000	0.006
B	1.397	1.803	0.055	0.071
b	0.250	0.560	0.010	0.022
C	2.591	2.997	0.102	0.118
D	2.692	3.099	0.106	0.122
e	0.838	1.041	0.033	0.041
H	0.080	0.254	0.003	0.010
L	0.300	0.610	0.012	0.024

单击下面可查看定价，库存，交付和生命周期等信息

[>>LOW POWER\(微源半导体\)](#)