



1A Single Chip Li-Ion and Li-Polymer Charger

General Description

The LP28019B is a complete constant-current/ constant voltage linear charger for single cell lithium-ion battery. Its ESOP8 package and low external component count make the LP28019B ideally suited for portable applications. No external sense resistor is needed, and no blocking diode is required due to the internal MOSFET architecture. Thermal feedback regulates the charge current to limit the die temperature during high power operation or high ambient temperature. The charge voltage is fixed at 4.2V, and the charge current can be ISET programmed externally with a single resistor.

The LP28019B automatically terminates the charge cycle when the charge current drops to 1/10 setting current value after the final float voltage is reached.

When the input supply is removed, the LP28019B automatically enters a low current state, dropping the battery drain current to less than < 1µA.

Other features include charge current monitor, under voltage lockout, automatic recharge and a status pin to indicate charge termination and the presence of an input voltage.

Order Information

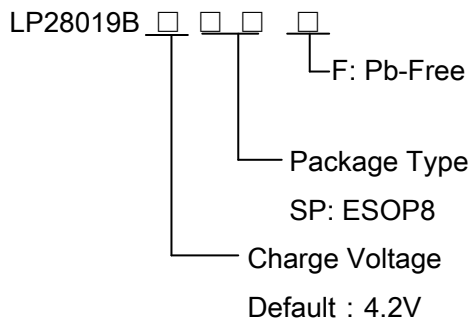

Applications

- ✧ Portable Media Players/Game
- ✧ Power Bank
- ✧ Bluetooth Applications
- ✧ PDA/MID

Features

- ◆ input voltage up to 28V
- ◆ input Over Voltage Protection : 7V
- ◆ Short-circuit protection
- ◆ Programmable Charge Current:300mA to 1000mA
- ◆ < 1µA Battery Reverse Current
- ◆ Protection of Reverse Connection of Battery
- ◆ No MOSFET, Sense Resistor or Blocking Diode Required
- ◆ Constant-Current/Constant-Voltage Operation with Thermal Regulation to Maximize Charge Rate Without Risk of Overheating
- ◆ ESOP8 Package
- ◆ RoHS Compliant and 100% Lead (Pb)-Free

Typical Application Circuit

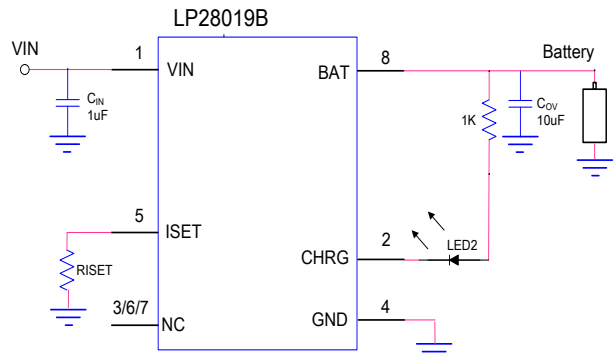

Marking Information

Device	Marking	Package	Shipping
LP28019BSPF	LPS LP28019B YWX	ESOP8	4K/REEL
Marking indication: Y:Production year W:Production week X: Series Number			



Functional Pin Description

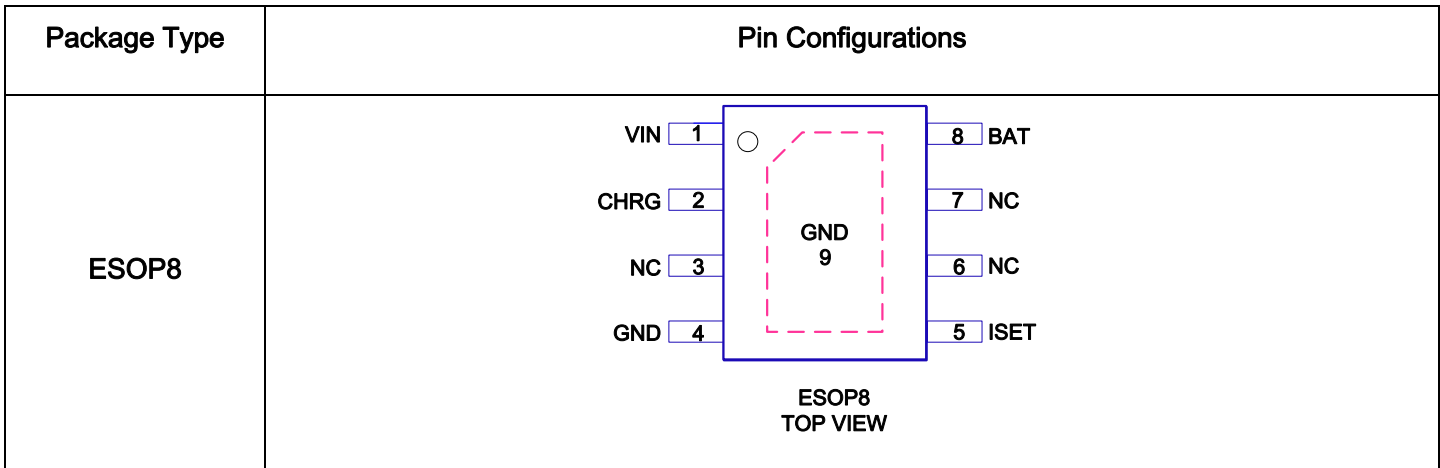

Pin Description

PIN No.	PIN NAME	DESCRIPTION
1	VIN	VIN is the input power source. Connect to a wall adapter.
2	CHRG	Open-Drain Charge Status Output. When the battery is charging, the CHRG pin is pulled low by an internal NMOS. When the charge cycle is completed, the pin could be pulled High by an external pull high resistor.
3	NC	No Connector.
4	GND	GND is the connection to system ground.
5	ISET	Charge Current Program. The charge current is programmed by connecting a 1% resistor(R_{ISET}) to ground.
6	NC	No Connector.
7	NC	No Connector.
8	BAT	BAT is the connection to the battery. Typically a 10 μ F Tantalum capacitor is needed for stability when there is no battery attached. When a battery is attached, only a 1 μ F ceramic capacitor is required.



Function Block Diagram

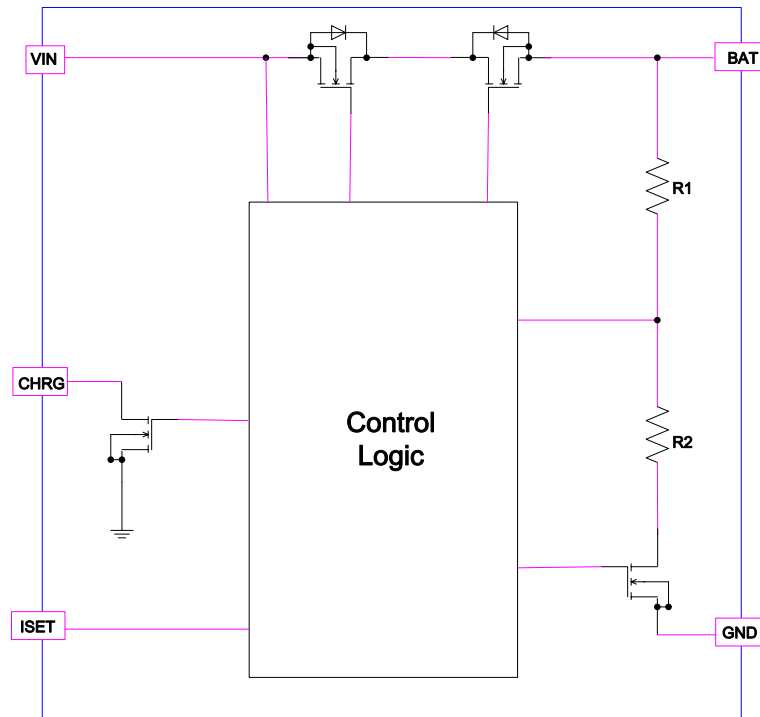

Absolute Maximum Ratings Note 1

- ◇ Input Voltage to GND ----- -0.3V to 28V
- ◇ BAT voltage GND ----- -5V to 7V
- ◇ Other pin to GND ----- -0.3V to 6.5V
- ◇ Maximum Junction Temperature ----- 125°C
- ◇ Maximum Soldering Temperature (at leads, 10 sec) ----- 260°C
- ◇ Storage Temperature ----- -55°C to 150°C

Thermal Information

- ◇ Maximum Power Dissipation (PD, T_A=25°C) ----- 1.5W
- ◇ Thermal Resistance (θ_{JA}) ----- 65°C/W

ESD Susceptibility

- ◇ HBM(Human Body Mode) ----- 2KV
- ◇ MM(Machine Mode) ----- 200V

Note 1. Stresses beyond those listed under “Absolute Maximum Ratings” may cause permanent damage to the device. These are stress ratings only, and functional operation of the device at these or any other conditions beyond those indicated in the operational sections of the specifications is not implied. Exposure to absolute maximum rating conditions for extended periods may affect device reliability.

Recommended Operating Conditions

- ◇ Input supply voltage ----- 4.5V to 6.5V
- ◇ Operating Junction Temperature Range (T_J) ----- -40°C to 85°C



Electrical Characteristics

($T_A = 25^\circ\text{C}$. $V_{IN} = 5\text{V}$, unless otherwise noted.)

SYMBOL	PARAMETER	CONDITIONS	MIN	TYP.	MAX	UNITS
I_{IN}	Input Supply Current	$I_{BAT} = 0$		1000		μA
V_{FLOAT}	Regulated Output (Float) Voltage	$I_{BAT} = 40\text{mA}$,	4.158	4.2	4.242	V
V_{UV}	V_{IN} Under voltage Lockout Threshold	From V_{IN} Low to High	3.1	3.3	3.5	V
V_{UVHYS}	V_{IN} Under voltage Lockout Hysteresis			150		mV
V_{OVP}	Input Voltage OVP	V_{IN} Rising	6.7	7	7.3	V
$V_{OVP-HYS}$	OVP Hysteresis			0.2		V
I_{BAT}	BAT Pin Current	$R_{ISET} = 1.5\text{k}$, Current Mode		1000		mA
		$V_{BAT} = 4.2\text{V}$		1		μA
		$V_{in} = \text{float or } 0\text{V}$		1		
I_{TRIKL}	Trickle Charge Current	$V_{BAT} < V_{TRIKL}$, $R_{ISET} = 1.5\text{k}$, Current Mode		10		% I_{BAT}
V_{TRIKL}	Trickle Charge Threshold Voltage	V_{BAT} Rising		2.6		V
V_{TRHYS}	Trickle Charge Hysteresis Voltage			150		mV
I_{TERM}	Termination Current Threshold			10		% I_{BAT}
V_{ISET}	ISET Pin Voltage	$R_{ISET} = 10\text{k}$, Current Mode		1		V
I_{CHRG}	CHRG Pin Weak Pull-Down Current	$V_{STAT} = 5\text{V}$			5	μA
V_{CHRG}	CHRG Pin Output Low Voltage	$I_{STAT} = 5\text{mA}$			0.1	V
ΔV_{RESTAT}	Recharge Battery Threshold Voltage	$V_{FLOAT} - V_{RESTAT}$		150		mV
T_{LIM}	Junction Temperature in Constant Temperature Mode			125		$^\circ\text{C}$



Application Information

Input Voltage Range

The LP28019B has built-in input voltage surge protection as high as +28V. The charger IC will be automatically disabled when the input voltage is lower than 4.4V or higher than 7.0V.

A charge cycle begins when the voltage at the VIN pin rises above the UVLO threshold level, when a battery is connected to the charger output. If the BAT pin is less than 2.6V, the charger enters trickle charge mode. In this mode, the LP28019B supplies approximately 1/10 the ISET programmed charge current to bring the battery voltage up to a safe level for full current charging. When the BAT pin voltage rises above 2.6V, the charger enters constant-current mode(CC), where the ISET programmed charge current is supplied to the battery. When the BAT pin approaches the final float voltage, the LP28019B enters constant-voltage mode(CV) and the charge current begins to decrease, and the battery full indication is set when the charge current in the CV mode is reduced to the programmed full battery current (1/10).

ISET programming Charge Current

The charge current (I_{BAT}) is set by a resistor (R_{ISET}) connecting from the ISET pin to GND. The relationship of the charge current and the programming resistance is established by the following table.

$R_{ISET}(K \Omega)$	$I_{BAT}(mA)$
1.5	1000
2	700
3.3	420
10	130

Automatic Recharge

Once the charge cycle is terminated, the LP28019B continuously monitors the voltage on the BAT pin. A charge cycle restarts when the battery voltage falls below 4.05V (which corresponds to approximately 80% to 90% battery capacity). This ensures that the battery is kept at or near a fully charged condition and eliminates the need for periodic charge cycle initiations.

Charge Termination

A charge cycle is terminated when the charge current falls to 1/10th the ISET programmed value after the final float voltage is reached. This condition is detected by using an internal, filtered comparator to monitor the ISET pin. When the ISET pin voltage falls below 100mV for longer than t_{TERM} (typically 1ms), charging is terminated.

The LP28019B constantly monitors the BAT pin voltage in standby mode. If this voltage drops below the 4.05V recharge threshold (V_{RESTAT}), another charge cycle begins and current is once again supplied to the battery. To manually restart a charge cycle when in standby mode, the input voltage must be removed and reapplied, or the charger must be shut down and restarted using the ISET pin.

Charge Status Indicator(CHRG)

After application of a 5V source, the input voltage rises above the U_{VLO} and sleep thresholds ($V_{IN} > V_{BAT} + V_{DT}$), but is less than OVP ($V_{IN} < V_{OVP}$), The charge status output has two different states: strong pull-down (~5mA) and high impedance. The strong pull-down state indicates that the LP28019B is in a charge cycle. Once the charge cycle has terminated, the pin state is determined by under voltage lockout conditions. High impedance indicates that the LP28019B is in under voltage lockout mode: either V_{IN} is less than 100mV above the BAT pin voltage or insufficient voltage is applied to the VIN pin.

A microprocessor can be used to distinguish between these two states—this method is discussed in the Applications Information section.

Function	CHRG
Charging	Low
Charge Finish	High



Thermal Limiting

An internal thermal feedback loop reduces the I_{SET} programmed charge current if the die temperature attempts to rise above a preset value of approximately 125°C. This feature protects the LP28019B from excessive temperature and allows the user to push the limits of the power handling capability of a given circuit board without risk of damaging the LP28019B. The charge current can be set according to typical (not worst-case) ambient temperature with the assurance that the charger will automatically reduce the current in worst-case conditions.

Power Dissipation

The conditions that cause the LP28019B to reduce charge current through thermal feedback can be approximated by considering the power dissipated in the IC. Nearly all of this power dissipation is generated by the internal MOSFET calculated to be approximately:

$$P_D = (V_{IN} - V_{BAT}) \cdot I_{BAT}$$

where P_D is the power dissipated, V_{IN} is the input supply voltage, V_{BAT} is the battery voltage and I_{BAT} is the charge current. The approximate ambient temperature at which the thermal feedback begins to protect the IC is:

$$T_A = 125^\circ\text{C} - P_D \cdot \theta_{JA}$$

$$T_A = 125^\circ\text{C} - (V_{IN} - V_{BAT}) \cdot I_{BAT} \cdot \theta_{JA}$$

Example: An LP28019B operating from a 5V USB supply is programmed to supply 1000mA full-scale current to a discharged Li-Ion battery with a voltage of 3.75V. Assuming θ_{JA} is 65°C / W (see Board Layout Considerations), the ambient temperature at which the LP28019B will begin to reduce the charge current is approximately:

$$T_A = 125^\circ\text{C} - (5\text{V} - 3.75\text{V}) \cdot (1000\text{mA}) \cdot 65^\circ\text{C}/\text{W}$$

$$T_A = 125^\circ\text{C} - 1\text{W} \cdot 65^\circ\text{C}/\text{W} = 125^\circ\text{C} - 65^\circ\text{C} \quad T_A = 60^\circ\text{C}$$

The LP28019B can be used above 60°C ambient, but the charge current will be reduced from 1000mA. The approximate current at a given ambient temperature can be approximated by:

$$I_{BAT} = (125^\circ\text{C} - T_A) / \theta_{JA} / (V_{IN} - V_{BAT})$$



Packaging Information

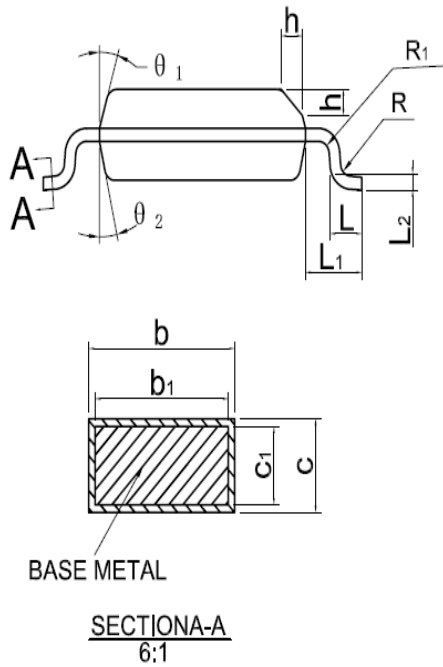
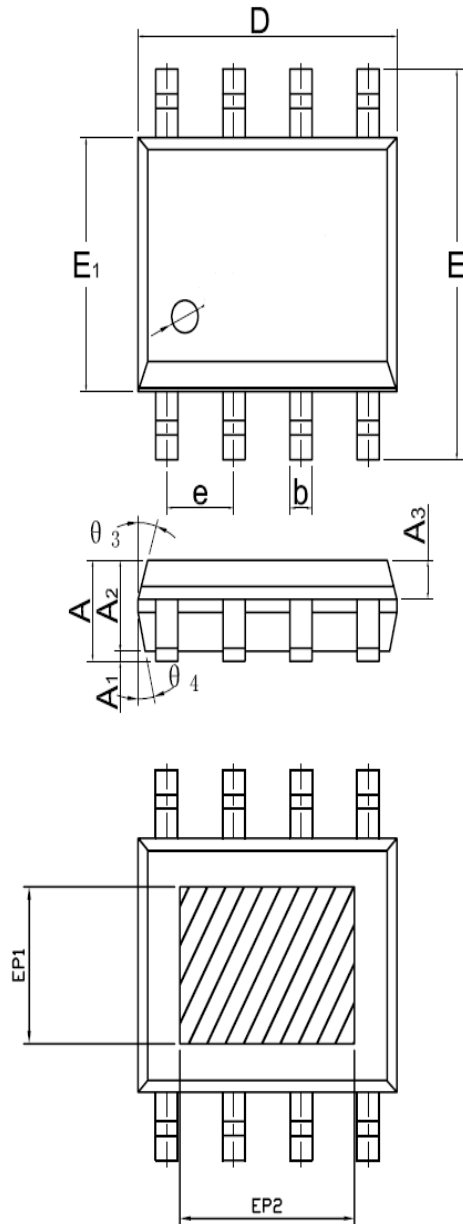

DIMENSIONS IN MILLIMETERS

SYMBOL	MIN	NOM	MAX
A	1,35	1,55	1,75
A ₁	0,00	—	0,10
A ₂	1,25	1,40	1,65
A ₃	0,50	0,60	0,70
b	0,39	—	0,49
b ₁	0,28	—	0,48
c	0,10	—	0,25
c ₁	0,10	—	0,23
D	4,80	4,90	5,00
E	5,80	6,00	6,20
E ₁	3,80	3,90	4,00
e	1,27BSC		
L	0,45	—	1,00
L ₁	1,04REF		
L ₂	0,25BSC		
R	0,07	—	—
R ₁	0,07	—	—
h	0,3	0,4	0,5
θ ₁	0°	—	8°
θ ₂	11°	17°	19°
θ ₃	11°	13°	15°
θ ₄	15°	17°	19°
EP1	2,40	—	—
EP2	3,30	—	—

单击下面可查看定价，库存，交付和生命周期等信息

[>>LOW POWER\(微源半导体\)](#)