



Filterless 2x8W Class- F Stereo Audio Amplifier

General Description

The LPA2153 is a 2x8W, class-F audio amplifier with EQ function for both channel. It offers low THD+N, allowing it to achieve high-quality Power Supply sound reproduction. The new filterless architecture allows the device to drive the speaker directly requiring no low-pass output filters, thus to save the system cost and PCB area.

LPA2153 can display 2x8W output at 10% THD with 2 Ω load. When it provides 5V DC voltage, it can provide 2x 3.4W output at 10% THD with 4 Ω load. The efficiency of LPA2153 is much better than that of class-AB cousins with the same numbers of external components. The LPA2153 is available in ESOP-16.

Order Information



Applications

- ✧ Portable Bluetooth Speaker
- ✧ Cellular and Smart mobile phone
- ✧ Square Speaker

Features

- ◆ 500KHz fixed frequency switching for amplifier
- ◆ 2x3.3W Output at 10% THD with a 4 Ω Load and 5V PVDD for amplifier
- ◆ 2x4.8W Output at 10% THD with a 4 Ω Load and 6.0V PVDD for amplifier
- ◆ 2x8W Output at 10% THD with a 2 Ω Load and 6.0V PVDD for amplifier
- ◆ Filterless, Low Quiescent Current and Low EMI
- ◆ Amplifier Efficiency up to 85%
- ◆ Free LC filter digital modulation, direct-drive speakers
- ◆ Thermal Shutdown
- ◆ Few external components to save the space and cost
- ◆ Pb-Free Package

Marking Information

Device	Marking	Package	Shipping
LPA2153	LPS LPA2153 YWX	ESOP-16	3K/REEL

Y: Y is year code. W: W is week code. X: X is series number.

Typical Application Circuit

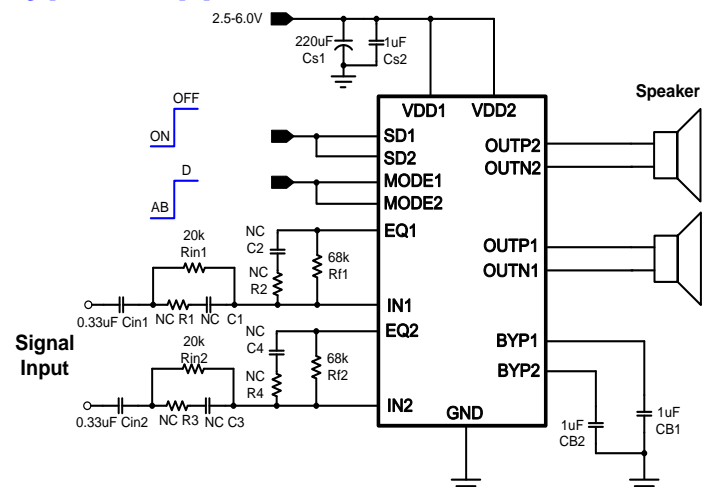



Pin Configuration

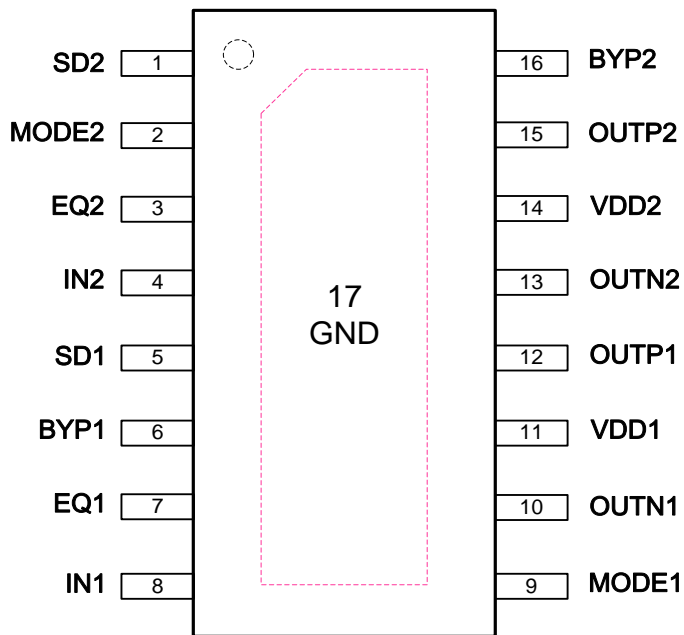

Functional Pin Description

Pin	PIN No.	DESCRIPTION
SD2	1	Channel 2 Shutdown pin (active high).
MODE2	2	Channel 2 Mode control pin (High voltage with Class_D mode and low voltage with Class_AB mode).
EQ2	3	Channel 2 EQ function pin(With resistor R4 and capacitor C4 in series between IN2 and EQ, the high frequencies could be attenuated).
IN2	4	Channel 2 Input of amplifier.(With resistor R3 and capacitor C3 in series between IN2 and signal, the low frequencies could be attenuated).
SD1	5	Channel 1 Shutdown pin (active high).
BYP1	6	Channel 1 Bypass pin (Connect a 0.22uF capacitor between this pin and GND).
EQ1	7	Channel 1 EQ function pin(With resistor R2 and capacitor C2 in series between VIN and EQ, the high frequencies could be attenuated).
IN1	8	Channel 1 Input of amplifier.(With resistor R1 and capacitor C1 in series between IN1 and signal, the low frequencies could be attenuated).
MODE1	9	Channel 1 Mode control pin (High voltage with Class_D mode and low voltage with Class_AB mode).
OUTN1	10	Channel 1 Negative output of signal.
VDD1	11	Channel 1 Voltage supply pin.
OUTP1	12	Channel 1 Positive output of signal.
OUTN2	13	Channel 2 Negative output of signal.
VDD2	14	Channel 2 Voltage supply pin.
OUTP2	15	Channel 2 Positive output of signal.
BYP2	16	Channel 2 Bypass pin (Connect a 0.22uF capacitor between this pin and GND).
GND	17	Ground pin.



Absolute Maximum Ratings

Input voltage	-0.3V to 6.5V
Lead Temperature (Soldering, 10 sec.)	260°C
Storage Temperature Range	-65°C to 150°C
Operation Junction Temperature Range	-40°C to 125°C
Operation Ambient Temperature Range	-40°C to 85°C
Maximum Junction Temperature Range	150°C

Recommended Operating Conditions

Supply Input Voltage range	2.5V to 6.0V
Operation Ambient Temperature Range	-40°C to 85°C
Operation Junction Temperature Range	-40°C to 125°C
Thermal resistance (junction to ambient)	110°C/W



**Electrical Characteristics For Both Channel**

(VDD = 5V, RL=4Ω , TA = 25° C, unless otherwise specified)

Parameter	Symbol	Test Conditions	Min	Typ(RL)		Max	Units
				Class-D	Class-AB		
Supply power	VIN		2.5			6.0	V
Output power	Po	THD+N=10%, f=1KHz,RL=4Ω	VDD=6.0V	4.8	4.7		W
			VDD=5.5V	4.0	3.9		
			VDD=5.0V	3.3	3.3		
			VDD=4.2V	2.3	2.3		
			VDD=3.6V	1.7	1.7		
		THD+N=1%, f=1KHz,RL=4Ω	VDD=6.0V	3.9	3.6		
			VDD=5.5V	3.3	3.1		
			VDD=5.0V	2.7	2.5		
			VDD=4.2V	1.9	1.8		
			VDD=3.6V	1.4	1.4		
		THD+N=10%, f=1KHz,RL=2Ω	VDD=6.0V	8	8		
			VDD=5.5V	6.8	6.7		
			VDD=5.0V	5.6	5.6		
			VDD=4.2V	3.3	3.9		
			VDD=3.6V	2.3	2.9		
Power supply ripple rejection	PSRR	INPUT ac-grounded with CIN=0.47uF, VDD=6.0V	f=100HZ		75		dB
			f=1KHz		50		
Signal-to-noise ratio	SNR	VDD=5V,Class_AB	f=1KHz		91		dB
		VDD=5V,Class_D	f=1KHz		90		
Output noise	V _N	INPUT ac-grounded with CIN=0.47uF, VDD=6.0V			100		μV
Efficiency	η	RL=4Ω, Po=3.2W	f=1KHz		84		%
Switching frequency	f _{sw}	VDD=2.5V to 5.5V			500		kHz
Output offset voltage	V _{os}	V _{SD} =0V, VDD=5.0V			1.1	2.5	mV
Shutdown current	I _{LEAK}	V _{SD} =VDD=5.0V			2		uA
Quiescent current	I _Q	VDD=5.0V	No load		4	6.8	mA



Typical Operating Characteristic For Both Channel

Audio Precision

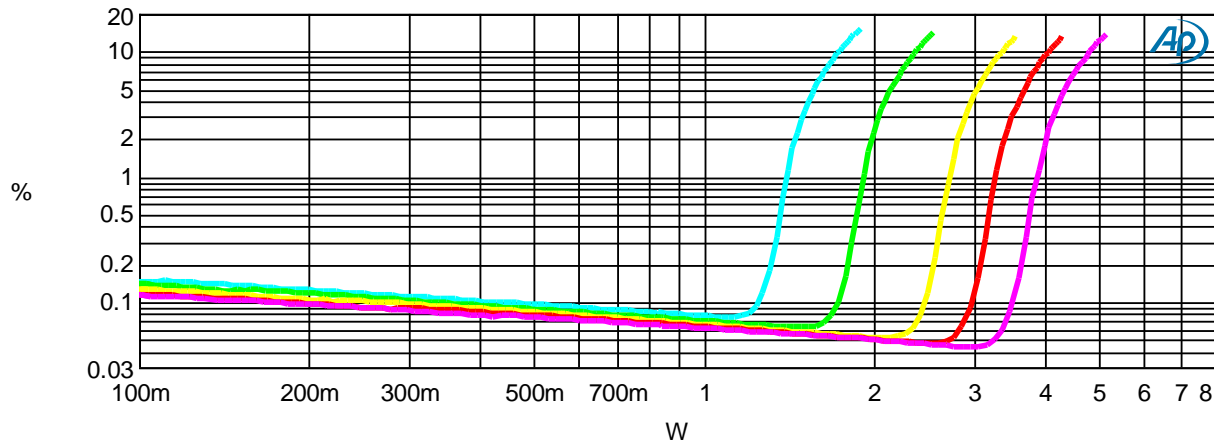

Sweep	Trace	Color	Line Style	Thick	Data	Axis	Comment
1	1	Cyan	Solid	3	Analyzer.TH _D +N Ratio A	Left	VDD=3.6V Class AB
2	1	Green	Solid	3	Analyzer.TH _D +N Ratio A	Left	VDD=4.2V Class AB
3	1	Yellow	Solid	3	Analyzer.TH _D +N Ratio A	Left	VDD=5.0V Class AB
4	1	Red	Solid	3	Analyzer.TH _D +N Ratio A	Left	VDD=5.5V Class AB
5	1	Magenta	Solid	3	Analyzer.TH _D +N Ratio A	Left	VDD=6.0V Class AB

PO VS THD(4ohm AB).ats2

Audio Precision

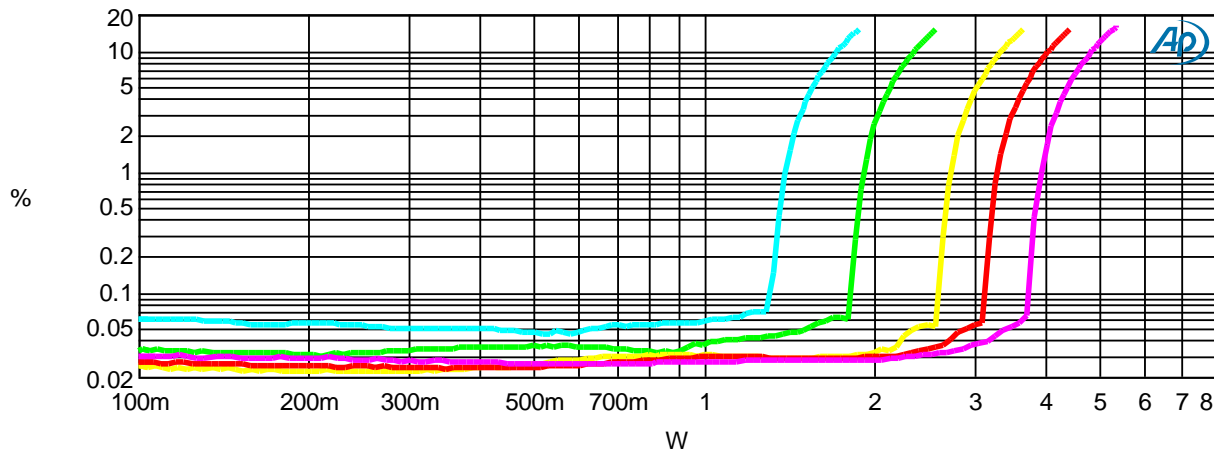

Sweep	Trace	Color	Line Style	Thick	Data	Axis	Comment
1	1	Cyan	Solid	3	Analyzer.TH _D +N Ratio A	Left	VDD=3.6V Class D
2	1	Green	Solid	3	Analyzer.TH _D +N Ratio A	Left	VDD=4.2V Class D
3	1	Yellow	Solid	3	Analyzer.TH _D +N Ratio A	Left	VDD=5.0V Class D
4	1	Red	Solid	3	Analyzer.TH _D +N Ratio A	Left	VDD=5.5V Class D
5	1	Magenta	Solid	3	Analyzer.TH _D +N Ratio A	Left	VDD=6.0V Class D

PO VS THD(4ohm D).ats2



Audio Precision

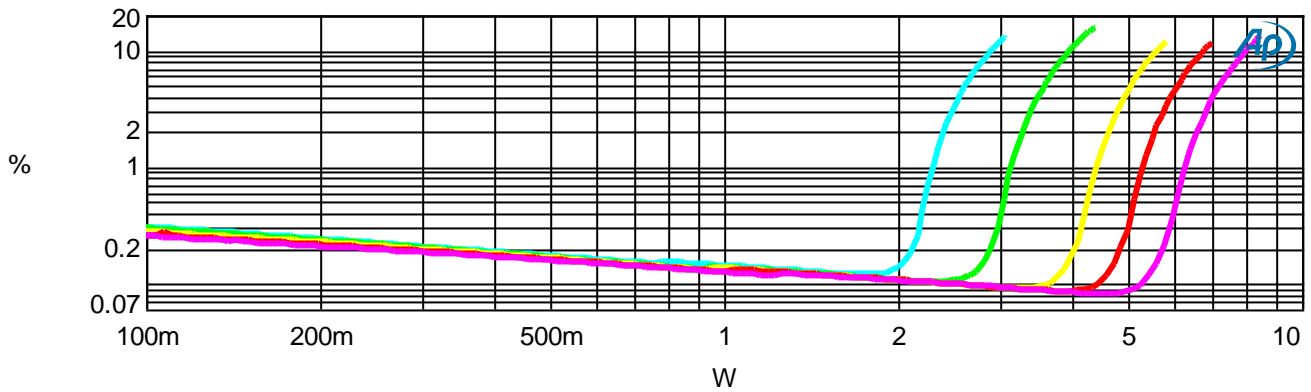

Sweep	Trace	Color	Line Style	Thick	Data	Axis	Comment
1	1	Cyan	Solid	3	Analyzer.THD+N Ratio A	Left	VDD=3.6V Class AB
2	1	Green	Solid	3	Analyzer.THD+N Ratio A	Left	VDD=4.2V Class AB
3	1	Yellow	Solid	3	Analyzer.THD+N Ratio A	Left	VDD=5.0V Class AB
4	1	Red	Solid	3	Analyzer.THD+N Ratio A	Left	VDD=5.5V Class AB
5	1	Magenta	Solid	3	Analyzer.THD+N Ratio A	Left	VDD=6.0V Class AB

P0 VS THD(2ohm AB).ats2

Classical Application 1: Low Restraint

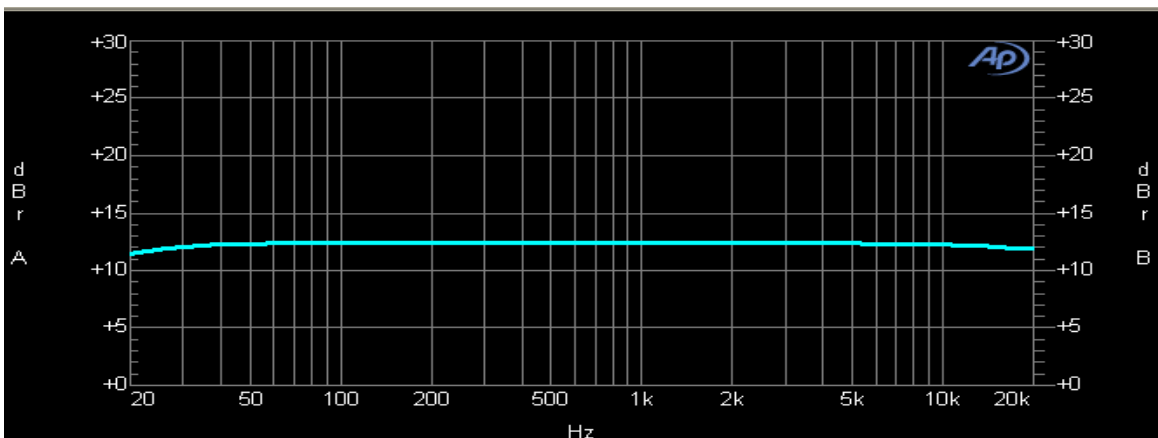
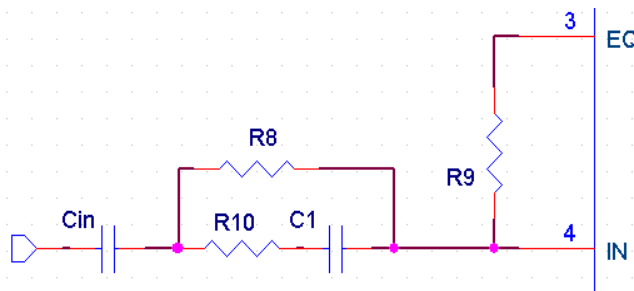

C1=NC, R10=NC, R8=18K, R9=33K, Cin=0.22uF

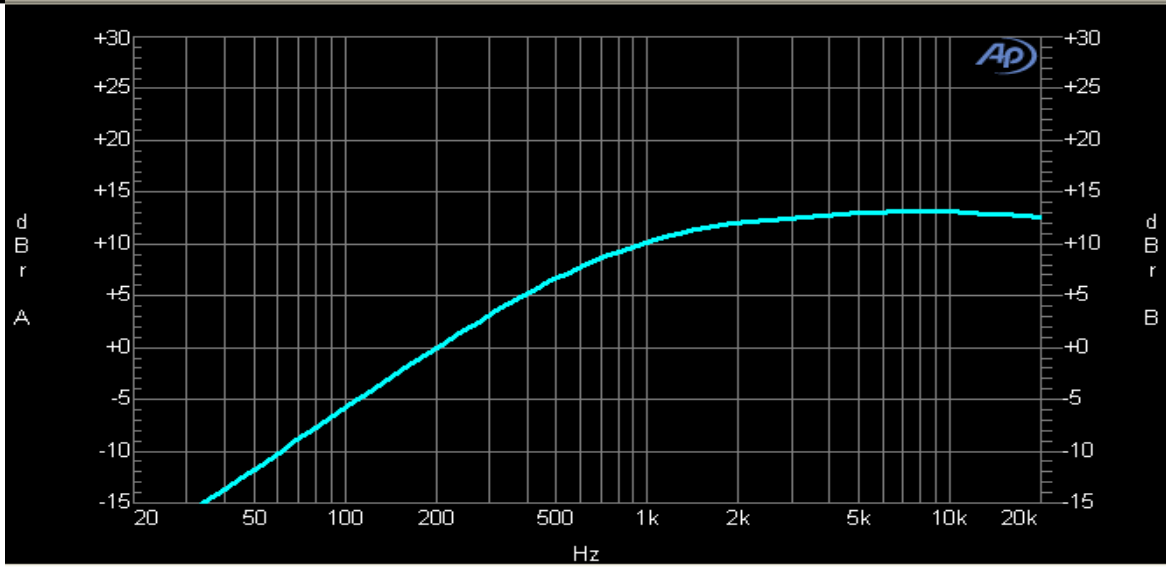

C1=10nF, R10=20K, R8=18K, R9=47K, Cin=0.1uF

Classical Application 2: High Restraint

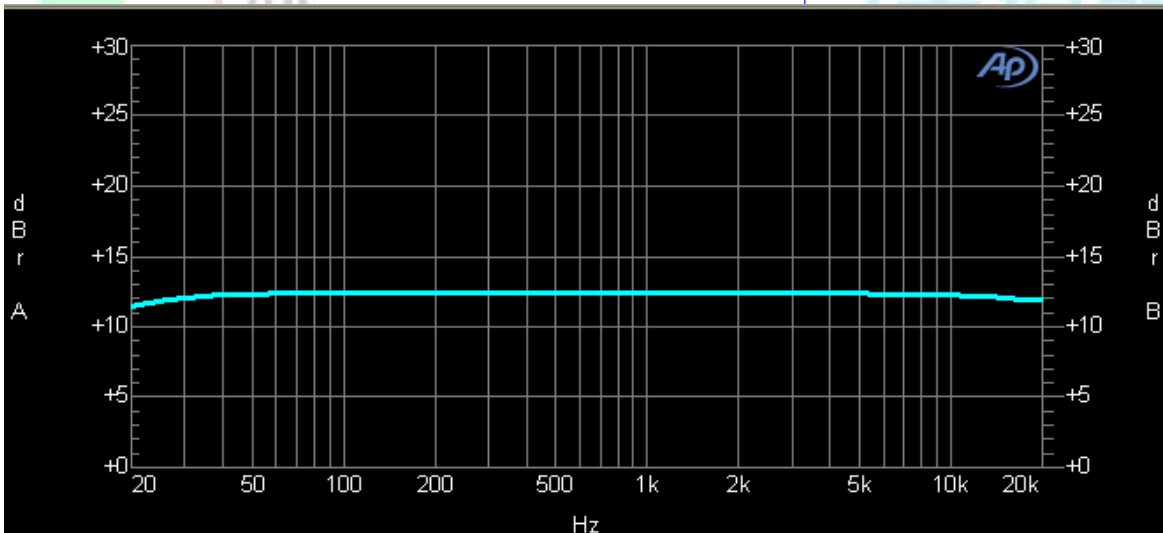
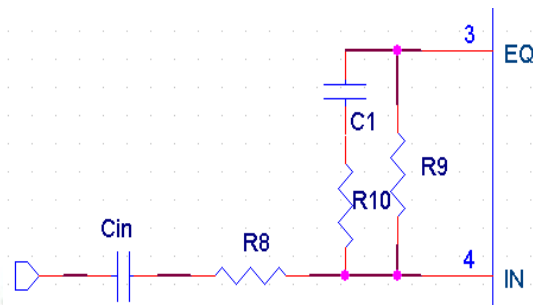

C1=NC, R10=NC, R8=18K, R9=33K, Cin=0.22uF

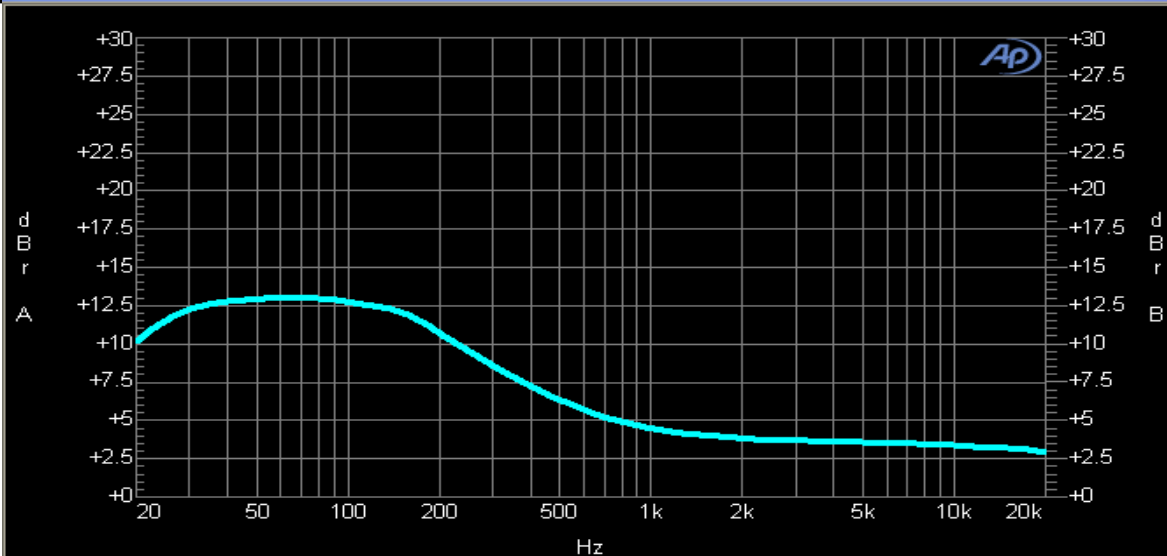

C1=33nF, R10=10K,R9=47K,R8=10K,Cin=1uF

Classical Application 3: High and Low Restraint (Band Pass)

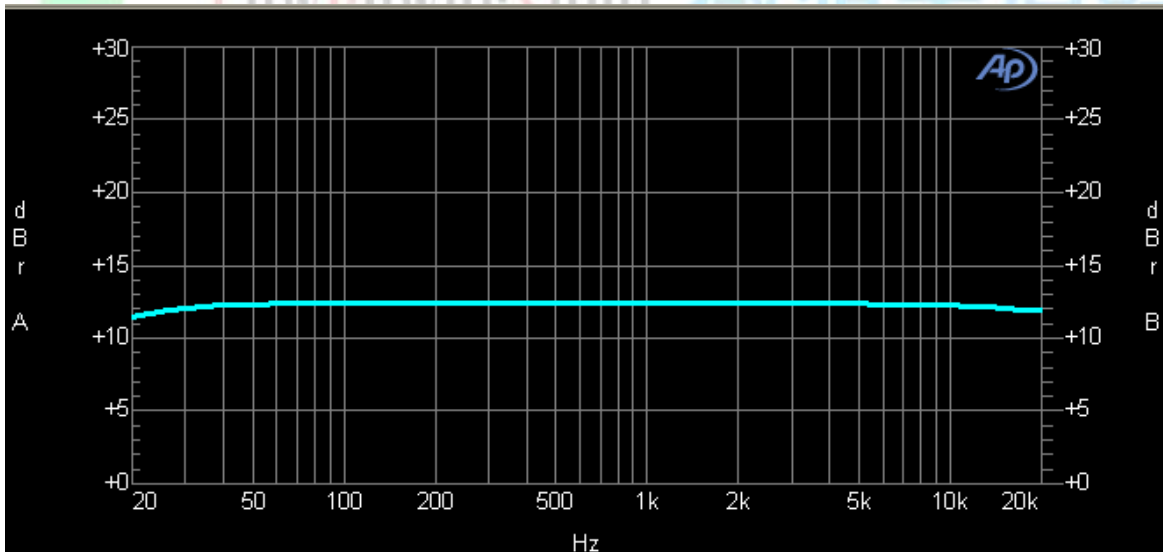
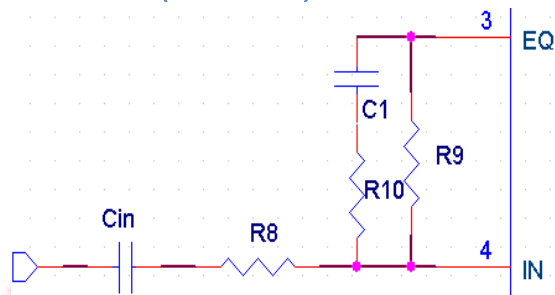

C1=NC, R10=NC, R8=18K, R9=33K, Cin=0.22uF

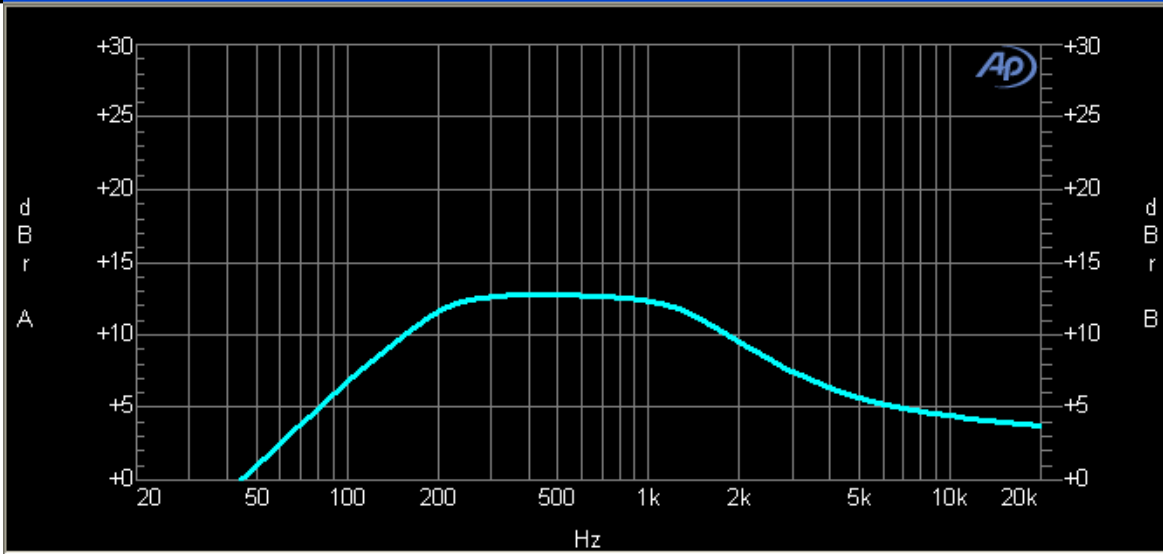

C1=10nF, R10=10K,R9=47K,R8=12K,Cin=0.047uF

Audio Precision

A-A THD+N vs FREQUENCY

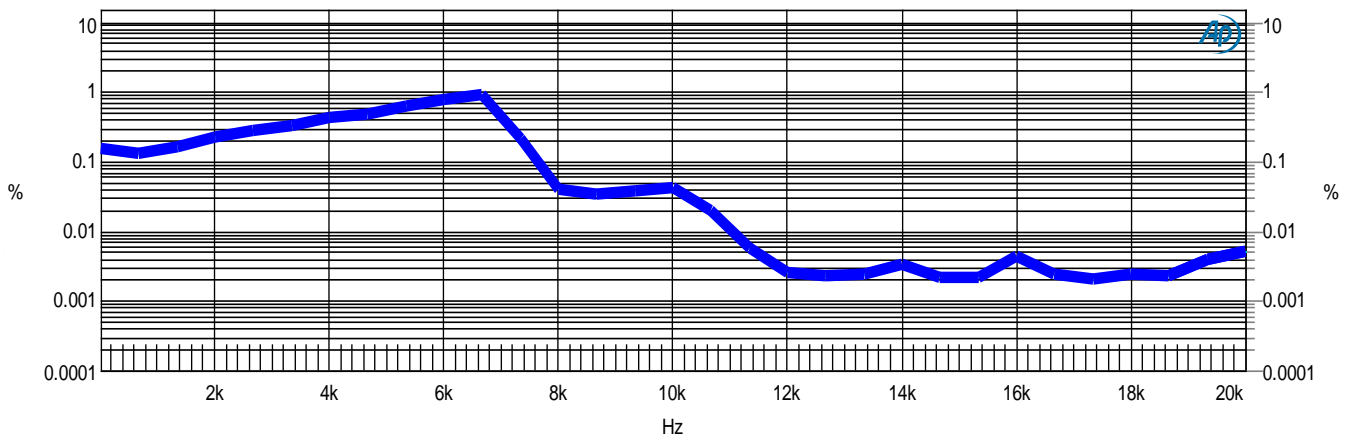

Sweep	Trace	Color	Line Style	Thick	Data	Axis	Comment
1	1	Cyan	Solid	1	Analyzer.TH+N Ratio B	Left	
1	2	Blue	Solid	7	Analyzer.TH+N Ratio B	Right	

A single sweeps produces a stereo THD+N sweep of Ch A and Ch B when data 1 is set for THD+N and the Stereo box is checked. The upper Analyzer bandwidth is 20kHz. At a 6kHz fundamental only the 2nd and 3rd harmonics are included, above 10kHz only the noise is included in the measurement bandwidth. For band-limited systems IMD testing is better.

A-A THD+N VS FREQ @4ohm PO=3W CLASS D VDD=6V.ats2



Audio Precision

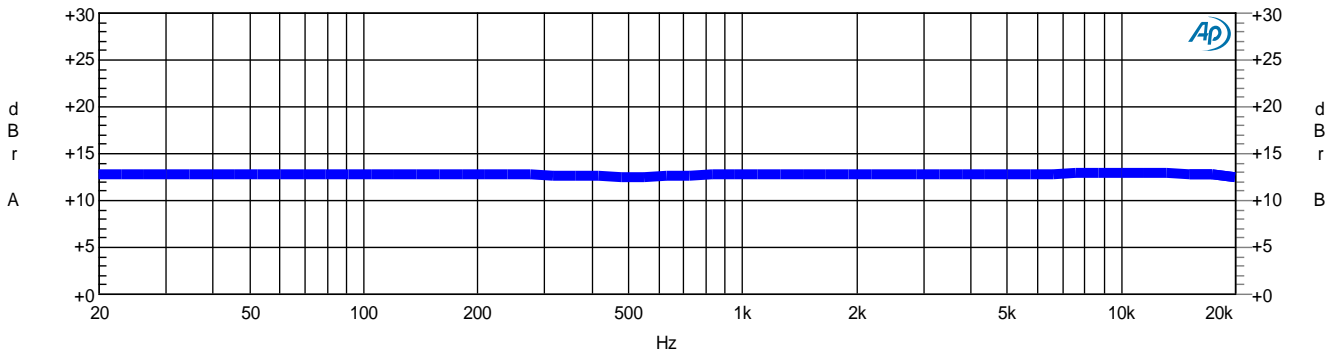

Sweep	Trace	Color	Line Style	Thick	Data	Axis	Comment
1	1	Cyan	Solid	1	Analyzer.Level A	Left	
1	2	Blue	Solid	7	Analyzer.Level B	Right	

Rapid (<2 seconds) frequency response measurement.
 Can be even faster if the lowest frequencies are not included.
 Press F4 to set the 1kHz dBr A and dBr B reference.
 Optimize for a detailed view.

A-A.FREQ RESP FAST @ 4ohm PO=4.8W CLASS AB VDD=6V.ats2

Applications Information For Both Channel

Maximum Gain

The LPA2153 has two internal amplifier stages. The first stage's gain is externally configurable, while the second stage's is internally fixed. The closed-loop gain of the first stage is set by selecting the ratio of Rf to Rin while the second stage's gain is fixed at 1.5x. The output of amplifier serves as the input to amplifier 2, thus the two amplifiers produce signals identical in magnitude, but different in phase by 180°.

Consequently, the differential gain for the IC is:

$$A_v = 2 * 1.5 * R_f / R_{in} \text{ (for class_AB \& class_D)}$$

Shutdown operation

In order to reduce power consumption while not in use, the LPA2153 contains shutdown circuitry to turn off the amplifier's bias circuitry. This shutdown feature turns the amplifier off when logic high is applied to the SD pin. By switching the SD pin pull up to VDD, the LPA2153 supply current draw will be minimized in idle mode.

Power supply decoupling

The LPA2153 is a high performance CMOS audio amplifier that requires adequate power supply decoupling to ensure the output THD and PSRR a low as possible. Optimum decoupling is achieved by using two capacitors of different types targeting to different types of noise on the power supply leads. For higher frequency transients, spikes, or digital hash on the line, a good low equivalent-series-resistance(ESR) ceramic capacitor, typically 1.0µF, works best, placing it as close as possible to the device VDD terminal. For filtering lower-frequency noise signals, a large capacitor of 20µF(ceramic) or greater is recommended, placing it near the audio power amplifier.

Signal Frequency suppress

The LPA2153 has a EQ pin which is the negative output of amplifier as show below. With R2 and C2, we can suppress high frequency part of signal. And the low frequency part of signal could be attenuated by R1 and C1.



$$f_H = \frac{1}{2\pi R_1 C_1}$$

$$f_L = \frac{1}{2\pi R_2 C_2}$$

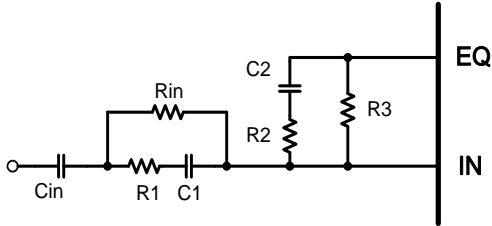

Over Temperature Protection

Thermal protection on the LPA2153 prevents the device from damage when the internal die temperature exceeds 150°C. There is a 15 degree tolerance on this trip point from device to device. Once the die temperature exceeds the thermal set point, the device outputs are disabled. This is not a latched fault. The thermal fault is cleared once the temperature of the die is reduced by 30°C. This large hysteresis will prevent motor boating sound well and the device begins normal operation at this point without external system intervention.

Analog Reference Bypass Capacitor (C_{BYP})

In addition to system cost and size, click and pop performance is affected by the size of the input coupling capacitor, C_{BYP}. A larger input coupling capacitor requires more charge to reach its quiescent DC voltage (nominally 1/2 VDD). This charge comes from the internal circuit via the feedback and is apt to create pops upon device enable. Thus, by minimizing the capacitor size based on necessary low frequency response, turn-on pops can be minimized.

The Analog Reference Bypass Capacitor (C_{BYP}) is the most critical capacitor and serves several important functions. During start-up or recovery from shutdown mode, C_{BYP} determines the rate at which the amplifier starts up. The second function is to reduce noise caused by the power supply coupling

into the output drive signal. This noise is from the internal analog reference to the amplifier, which appears as degraded PSRR and THD+N.

How to reduce EMI

A simple solution is to put an additional capacitor 220pF at power supply terminal for power line. The traces from amplifier to speakers should design as short as we can.

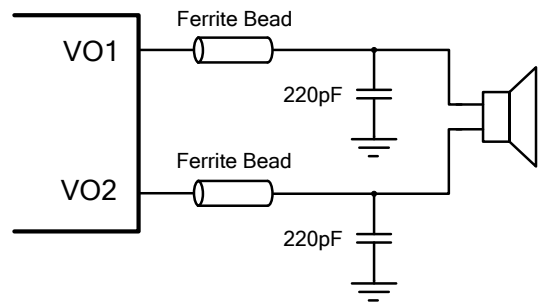



PCB LAYOUT

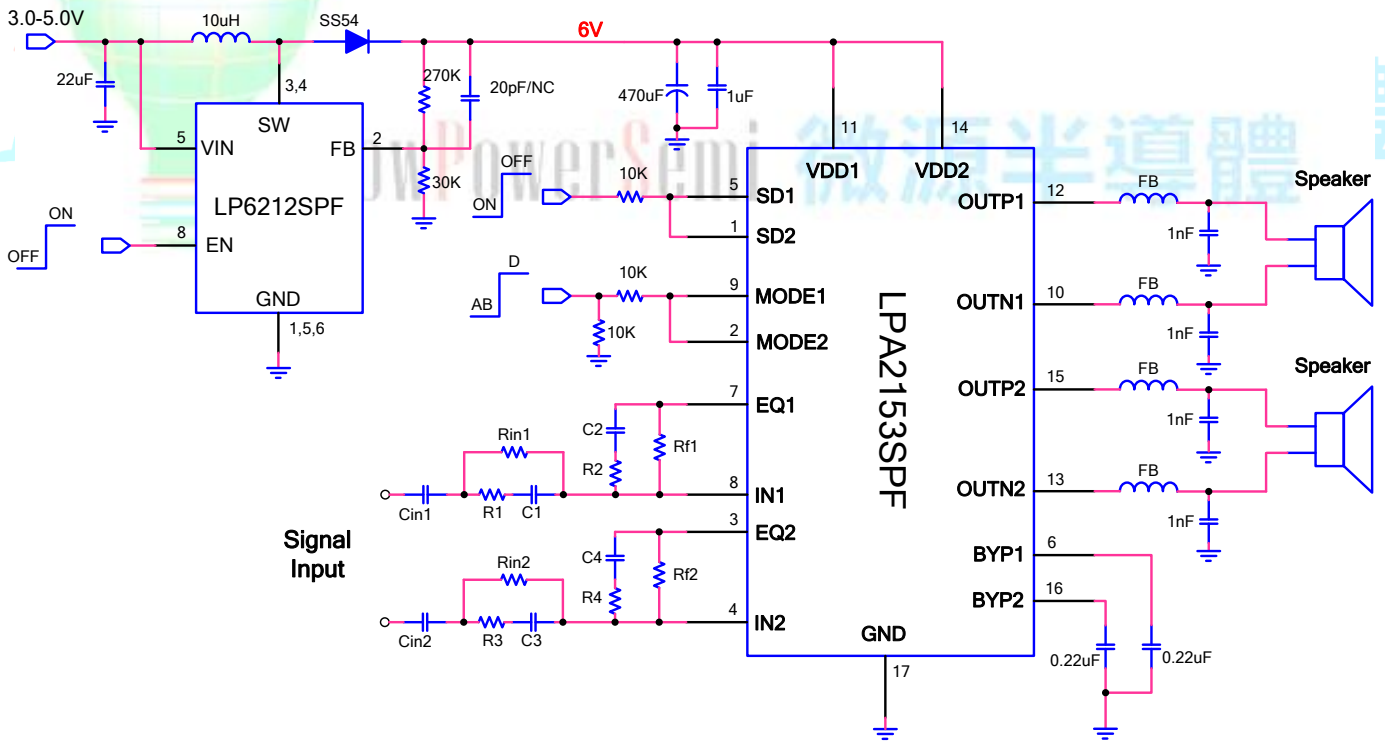
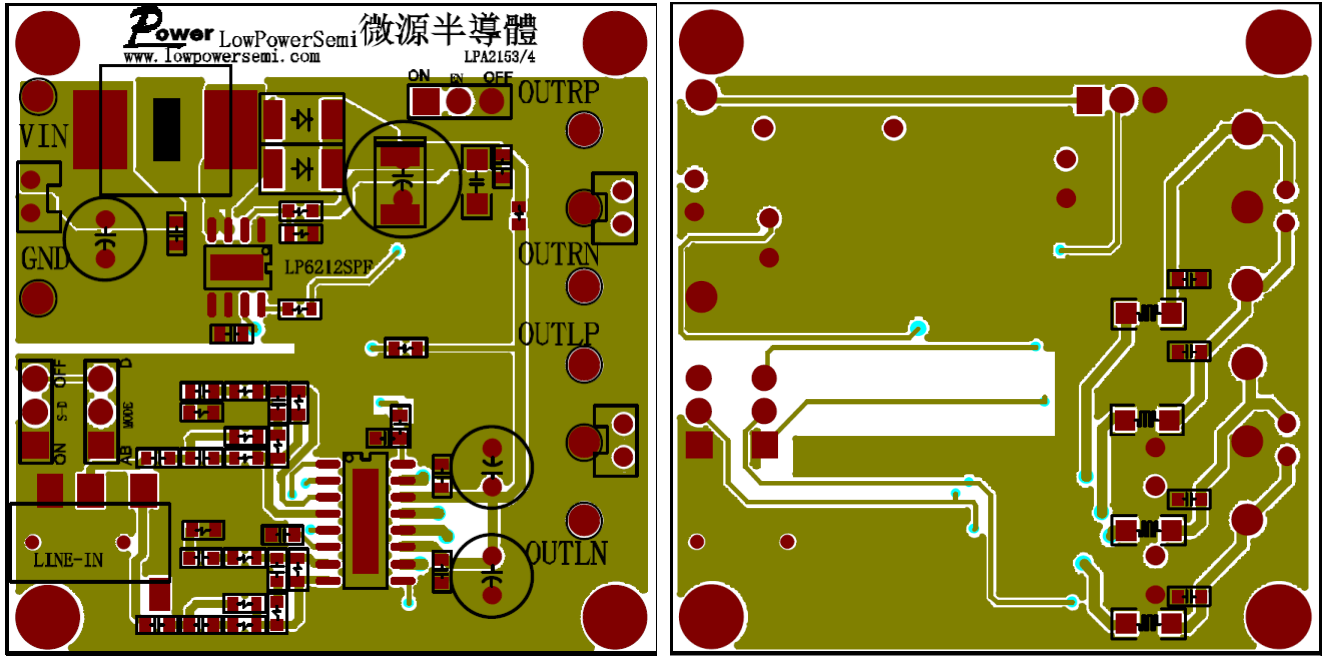



Packaging Information

ESOP16

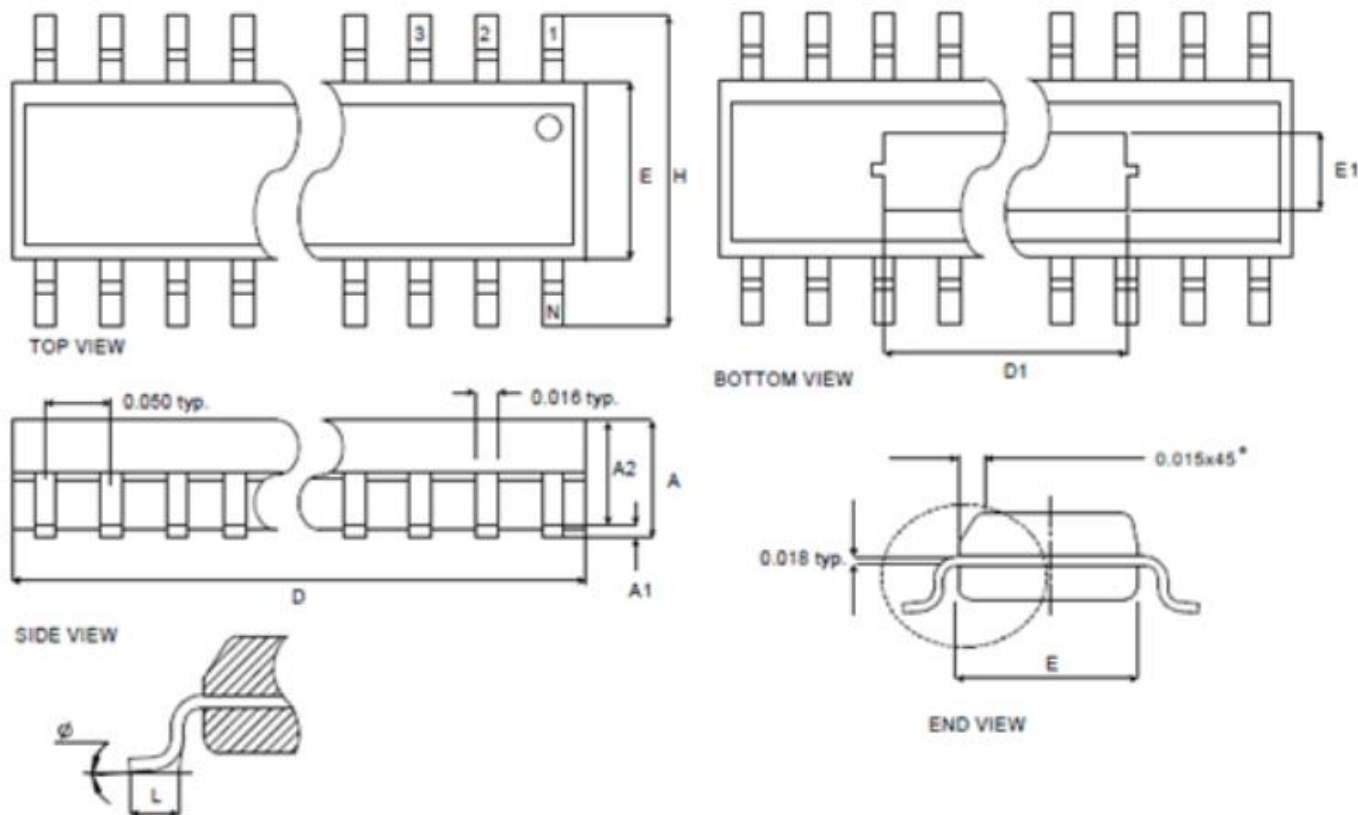

Dim	Millimeters		Inches	
	Min.	Max.	Min.	Max.
A	1.35	1.75	0.053	0.069
A1	0.10	0.25	0.004	0.010
D	9.80	10.0	0.386	0.394
D1	4.115 REF		0.162 REF	
E	3.81	3.99	0.150	0.157
E1	2.184 REF		0.086 REF	
H	5.79	6.20	0.228	0.244
L	0.41	1.27	0.016	0.050
ϕ	0°	8°	0°	8°

单击下面可查看定价，库存，交付和生命周期等信息

[>>LOW POWER\(微源半导体\)](#)