

Over Voltage Protection IC with Surge Protection

General Description

The LP5280 series is a highly integrated circuit, it used to protect low voltage system from abnormal high input voltage. The IC continuously checks the input voltage. When the protection status is occur, the power MOS will turn off at the same time. The LP5280 series is safety devices to ensure worked against accidents.

In case of the OVLO pin voltage exceeds an Over-Voltage Protection (OVP) threshold voltage level, the internal power MOS will turn off within 1 μ s. Input voltage OVP threshold could be used to set by external resistors divider. Also, LP5280 has an input 6.8V-OVP, LP5280A was 5.95V-OVP, LP5280B was 10.5V-OVP, and LP5280C was 14V-OVP, which could be select by connecting OVLO pin to ground.

Other features include over temperature protection and under-voltage lockout (UVLO). The LP5280 series is available in a space saving WLCSP 12-ball (0.4mm pitch) package.

Order Information

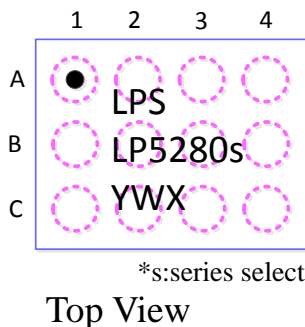
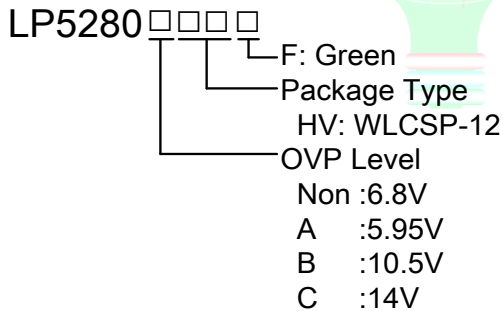

Features

- ◆ Withstand High Input Voltage Up to 29V
- ◆ Input Over Voltage Protection
 - Internal Input OVP=6.8V_(Typ.) @LP5280
 - Internal Input OVP=5.95V_(Typ.) @LP5280A
 - Internal Input OVP=10.5V_(Typ.) @LP5280B
 - Internal Input OVP=14V_(Typ.) @LP5280C
- ◆ OVP Response Time=40ns_(Typ.)
- ◆ 4.8A Current Capability
- ◆ Power MOS R_{DS(ON)}=25m Ω _(Typ.)
- ◆ Fault Signal Output
- ◆ Enable Control
- ◆ Under Voltage Lockout
- ◆ Over-Temperature Protection
- ◆ IEC61000-4-5 Surge >100V
- ◆ Available in WLCSP12
- ◆ RoHS Compliant and Halogen Free

Applications

- ◆ Mobile Handsets and Tablets
- ◆ Portable Media Players
- ◆ MP3 Players
- ◆ Charging Ports

Marking and Package Information

Device	Marking	Package	MSL	Shipping
LP5280HVF	LPS LP5280 YWX	WLCSP-12	MSL1	3K/REEL
LP5280AHVF	LPS LP5280A YWX	WLCSP-12	MSL1	3K/REEL
LP5280BHVF	LPS LP5280B YWX	WLCSP-12	MSL1	3K/REEL
LP5280CHVF	LPS LP5280C YWX	WLCSP-12	MSL1	3K/REEL

Marking indication:

Y: Y is year code. W: W is week code. X: X is series number.

Typical Application Circuit

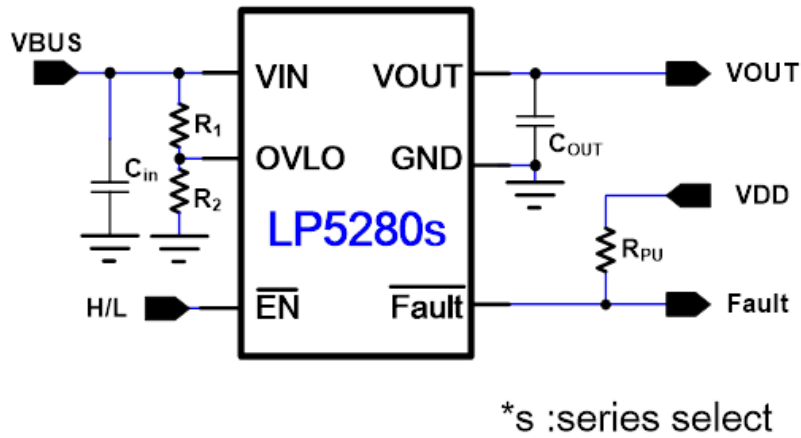

Figure 1. Typical Application Circuit of LP5280 series

Pin Configuration

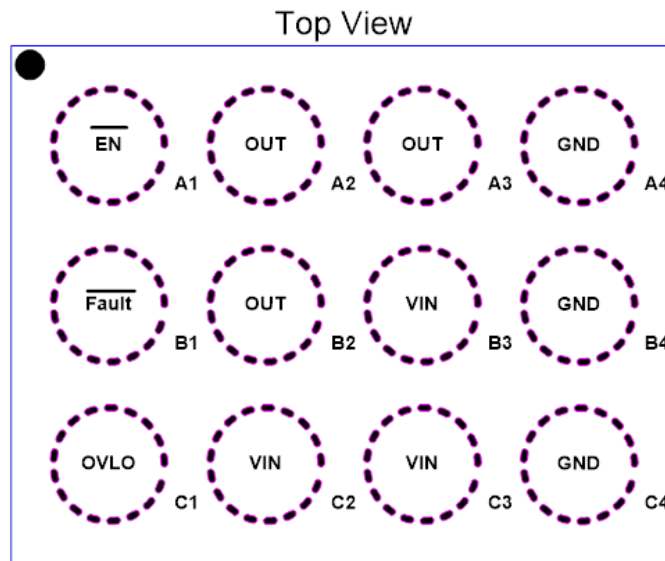

Figure 2. Package Top View

Function Block Diagram

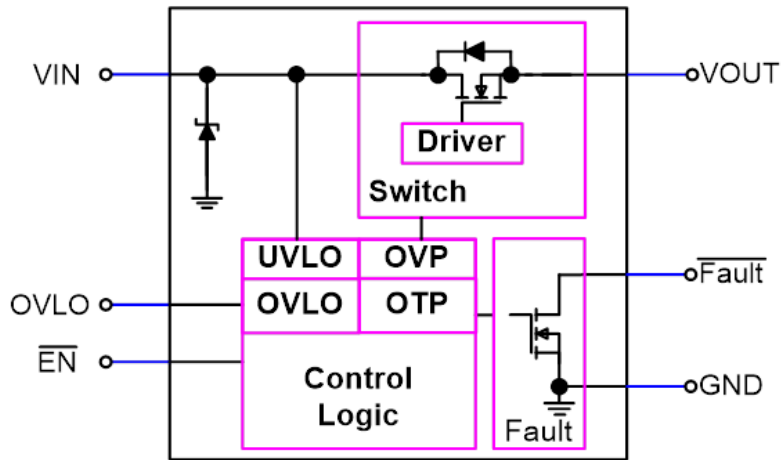

Figure 3. Function Block Diagram

Functional Pin Description

Pin NO.	WLCSP	Description
VIN	B3,C2,C3	Power Source Input. Connect a ceramic capacitor between VIN and GND.
GND	A4,B4,C4	Ground.
$\overline{\text{Fault}}$	B1	Fault Function Pin. Open drain connected to a resistor.
$\overline{\text{EN}}$	A1	Enable Pin.
OVLO	C1	Over Voltage Lockout. Adjustment Pin.
VOUT	A2,A3,B2	Output through the power MOSFET.

Absolute Maximum Ratings ^{Note1}

◇ VIN to GND	-----	-0.3V to +29V
◇ VOUT to GND	-----	-0.3V to +29V
◇ OVLO to GND	-----	-0.3V to +24V
◇ All Other Pin to GND	-----	-0.3V to +6V
◇ Operating Junction Temperature Range (T _J)	-----	-40°C to 150°C
◇ Operation Ambient Temperature Range	-----	-40°C to +105°C
◇ Storage Temperature Range	-----	-55°C to +150°C
◇ Maximum Soldering Temperature (at leads, 10sec)	-----	+260°C

Note1. Stresses beyond those listed under “Absolute Maximum Ratings” may cause permanent damage to the device. These are stress ratings only, and functional operation of the device at these or any other conditions beyond those indicated in the operational sections of the specifications is not implied. Exposure to absolute maximum rating conditions for extended periods may affect device reliability.



Electrical Characteristics

($T_A = 25^\circ\text{C}$, $V_{IN} = 5\text{V}$, $V_{EN} = 0\text{V}$, $OVLO = 0\text{V}$, $C_{IN} = 0.1\mu\text{F}$, and $C_{OUT} = 1\mu\text{F}$. Unless Otherwise Specified)

Parameter	Symbol	Test Conditions	Min	Typ	Max	Units
General Function						
Input Clamp Voltage	V_{IN_Clamp}			31		V
Power Source Voltage	V_{IN}	$T_J = +25^\circ\text{C}$	2.5	5	28	V
Input UVLO Threshold	V_{UVLO}	V_{IN} Rising		2.25		V
UVLO Threshold Hysteresis	ΔV_{UVLO}	Falling Hysteresis		150		mV
Power On Deglitch Time	$T_{Deglitch}$	From $V_{IN} > UVLO$ to 10% V_{OUT} , \overline{EN} Low		20		ms
Soft Start Time	T_{SS}	From $V_{IN} > UVLO$ to \overline{Fault} low, \overline{EN} Low		30		ms
Power Source Current at Operation	I_{IN}	$V_{IN} = 5\text{V}$, $\overline{EN} = L$		67		μA
Power Source Current at OV Condition	I_{IN_OVLO}	$V_{IN} = 5\text{V}$, $\overline{EN} = L$, $OVLO = 3\text{V}$		70		μA
Thermal Shutdown Threshold	T_{SD}			130		$^\circ\text{C}$
Thermal Shutdown Threshold Hysteresis	ΔT_{SD}			20		$^\circ\text{C}$
Logic Function						
\overline{EN} Threshold Voltage	V_{ENH}		1			V
	V_{ENL}				0.5	V
\overline{EN} Input Resistance to GND	I_{EN}	$\overline{EN} = 5\text{V}$			5	μA
\overline{Fault} Output Logic Low		Sink 1mA			0.4	V
\overline{Fault} Logic High Leakage Current		$\overline{Fault} = 5\text{V}$	-0.5		0.5	μA
Power MOS						
Switch On Resistance	$R_{DS(ON)}$	$I_{OUT} = 1\text{A}$		25		$\text{m}\Omega$
Switch Turn on Time	T_{ON}	$R_{OUT} = 100\ \Omega$, $C_{OUT} = 22\mu\text{F}$, V_{OUT} from $0.1V_{IN}$ to $0.9V_{IN}$		1		ms
Switch Turn off Time	T_{OFF}	$R_{OUT} = 100\ \Omega$, $C_{OUT} = \text{Non}$, Trigger OVLO to stop V_{OUT}		40		ns
External OVLO Function						
OVLO Leakage Current	I_{OVLO}		-0.1		+0.1	μA
External OVLO Set Threshold	V_{EOVLO}			1.2		V
External OVLO select Threshold	V_{EOV_H}			0.4		V
External OVLO select Threshold Hysteresis	V_{EOV_L}			0.3		V

Electrical Characteristics

($V_{IN} = 5V, T_A = 25^{\circ}C$, Unless Otherwise Specified)

Parameter	Symbol	Test Conditions	Min	Typ	Max	Units	
Internal OVLO Functions							
Input Over Voltage Protect threshold	V_{IOVLO}	LP5280	V_{IN} Rising	6.6	6.8	7	V
			V_{IN} Falling	6.51	6.65		V
		LP5280A	V_{IN} Rising	5.83	5.95	6.07	V
			V_{IN} Falling	5.73	5.85		V
		LP5280B	V_{IN} Rising	10.3	10.5	10.7	V
			V_{IN} Falling	10.1	10.3		V
		LP5280C	V_{IN} Rising	13.7	14	14.3	V
			V_{IN} Falling	13.4	13.7		V

Timing Diagram

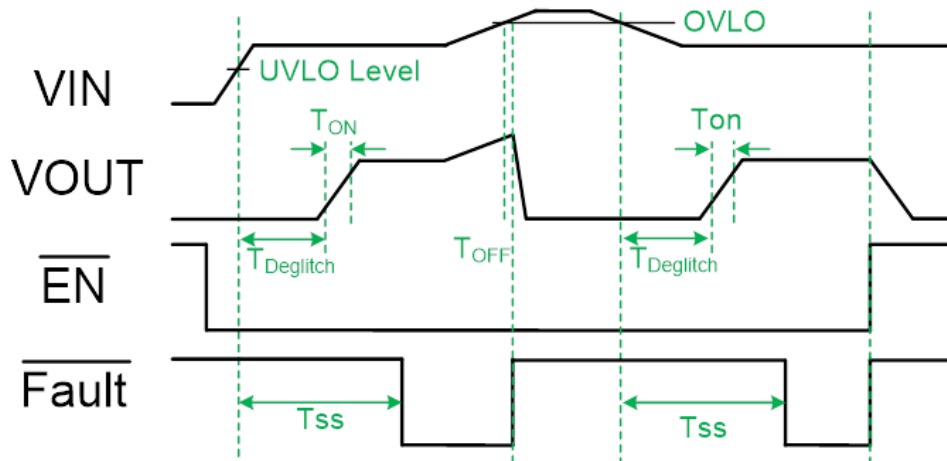

Figure 4. Power Sequence

Application Information

The LP5280 series devices monitor the input voltage to protect the OTG system of a Li-Ion battery. When enabled, the system is protected against input overvoltage by turning off an internal switch, immediately removing power from the charging circuit. Additionally, the device also monitors its own temperature and switches off if device too hot.

Under Voltage Lockout (UVLO)

The LP5280 series had an UVLO internal circuit that enables the device once the voltage on the V_{IN} voltage exceeds the UVLO threshold voltage.

Surge Protection

The LP5280 series integrates a clamp circuit to suppress input surge voltage. For surge voltages large than V_{OVLO} and small than V_{IN_Clamp} , the switch will be turned off and the clamp circuit is not work. For surge voltages greater than V_{IN_Clamp} , the internal clamp circuit will detect surge voltage level and discharge the surge energy to ground. The device can suppress surge voltages up to 100V.

Over Temperature Protection

The LP5280 series device enters over temperature protection (OTP) if its junction temperature exceeds 130°C (Typ.). During over temperature protection none of the device's functions are available. To resume normal operation the junction temperature need cool down, and the outputs will restart.

Enable Control

The LP5280 series has an enable pin which can be used to enable or disable the device. When the EN pin is driven high, the switch is turned off. The EN pin has an internal pull-down resistor can be floating.

Fault Output

The FAULT pin is open-drain output.

- Input Over Voltage
- OVLO Voltage Threshold
- Over Temperature

External Over Voltage Lockout

The power MOS will be turned off whenever input voltage higher than V_{IOVLO} . The value of V_{OVLO} can be set by external resistor divide or just be internal set value V_{IOVLO} .

When V_{OVLO} is smaller than V_{EOV_L} , V_{OVLO} will be decided by V_{IOVLO} . When V_{OVLO} is larger than V_{EOV_H} , the power switch will be turned off once $V_{OVLO} > V_{EOVLO}$. The external resistor divide can be decided according to the following equation:

$$V_{OVLO} = (R1/R2 + 1) \times V_{EOVLO}$$

Layout Consideration

The proper PCB layout and component placement are critical for all circuit. LP5280 series is meant to protect downstream circuit. Here are some suggestions to the layout design.

1. Route power line on PCB as straight, wide and short as possible.
2. Connected all ground together with one uninterrupted ground plane.
3. The input and output capacitor should be located as closed as possible to the chip and ground plane.
4. Other components should be located close to the chip.
5. The power trace from connector to device may suffer from ESD event; keep other traces away from it to minimize possible EMI and ESD coupling.

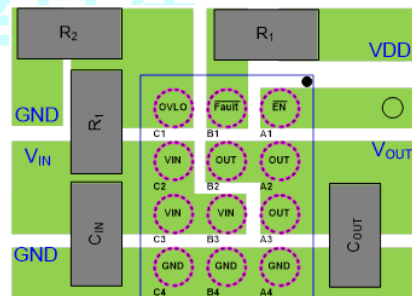
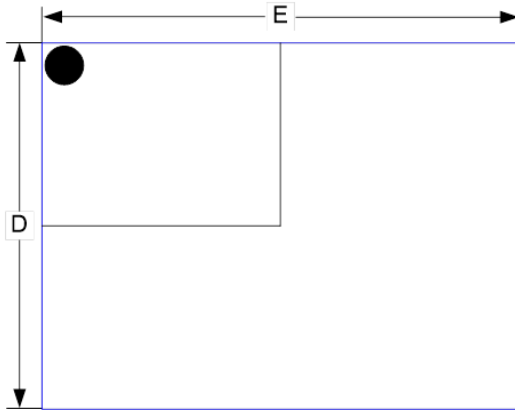

Figure 5. Recommended PCB Layout Diagram

Packaging Information

WLCSP-12-ball Package(1.3x1.78) pitch 0.4 (Unit: mm)



TOP VIEW

SYMBOLSU NIT	DIMENSION IN MILLIMETER		
	MIN	TYP	MAX
D	1.30	1.33	1.36
E	1.77	1.79	1.82
S	0.37	0.38	0.39
D1	0.8		
E1	1.2		
A1	0.14	0.165	0.18
e	0.4		

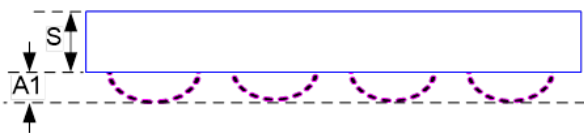

SIDE VIEW

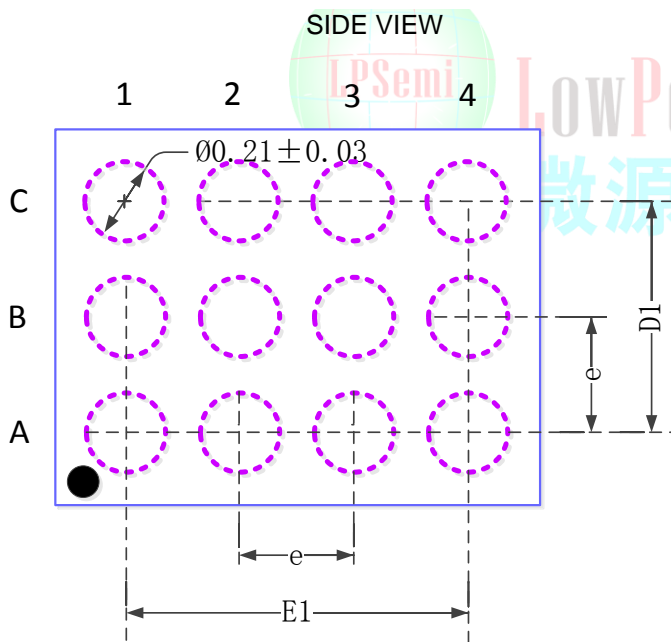

BOTTOM VIEW

Tape and Reel information

REEL DIMENSIONS (Unit:mm)

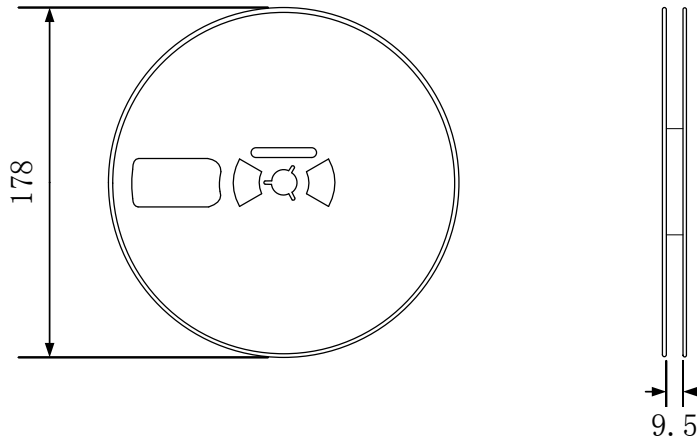

TAPE DIMENSIONS (Unit:mm)

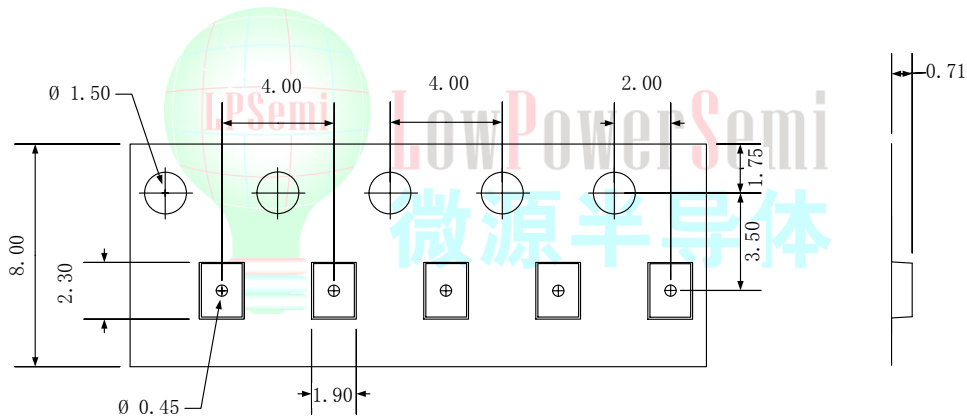

PIN1 AND TAPE FEEDING DIRECTION

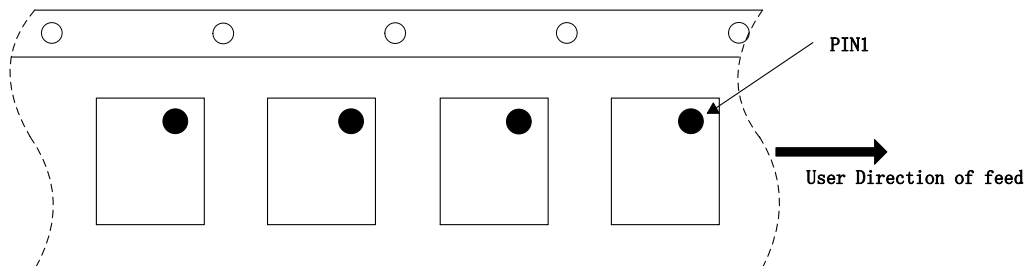

单击下面可查看定价，库存，交付和生命周期等信息

[>>LOW POWER\(微源半导体\)](#)