



High Efficiency 6A Boost DC/DC Converter

General Description

The LP6212 is a current mode boost DC-DC converter. Its PWM circuitry with built-in 6A (ESOP8) Current power MOSFET makes this converter highly efficient. The LP6212 implements a constant frequency 1.2MHz PWM control scheme. The high frequency PWM operation also saves board space by reducing external component sizes. The LP6212 features automatic shifting to pulse frequency modulation mode at light loads. Highly integration and internal compensation network minimizes as 6 external component counts. Optimized operation frequency can meet the requirement of small LC filters value and low operation current with high efficiency. The LP6212 includes under-voltage lockout, current limiting, and thermal overload protection to prevent damage in the event of an output overload. The LP6212 is available in a small ESOP8/SOT23-6 package.

Order Information

LP6212

F: Pb-Free

Package Type
 SP: ESOP8
 B6: SOT23-6

Applications

- ✧ Battery products
- ✧ Host Products
- ✧ Panel

Features

- ◆ Up to 94% efficiency
- ◆ Shut-down current:<1uA
- ◆ Output voltage Up to 5V/2.1A
- ◆ Internal Compensation
- ◆ 1.2MHz fixed frequency switching
- ◆ High switch on current:
 6A for LP6212SPF
 4A for LP6212B6F
- ◆ Available in ESOP8 and SOT23-6 Package

Typical Application Circuit

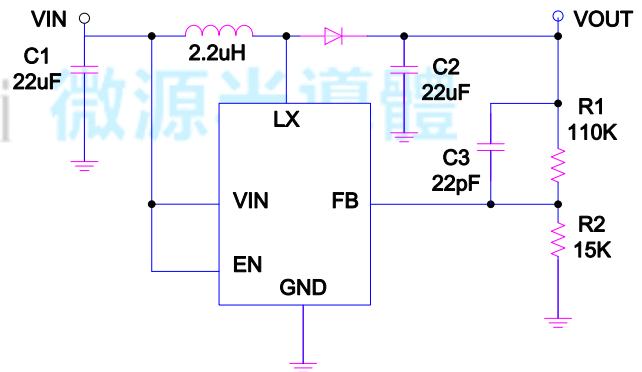

Marking Information

Device	Marking	Package	Shipping
LP6212SPF	LPS LP6212 YWX	ESOP8	2.5K/REEL
LP6212B6F		SOT23-6	3K/REEL

Y: Year code. W: Week code. X: Batch numbers.



Functional Pin Description

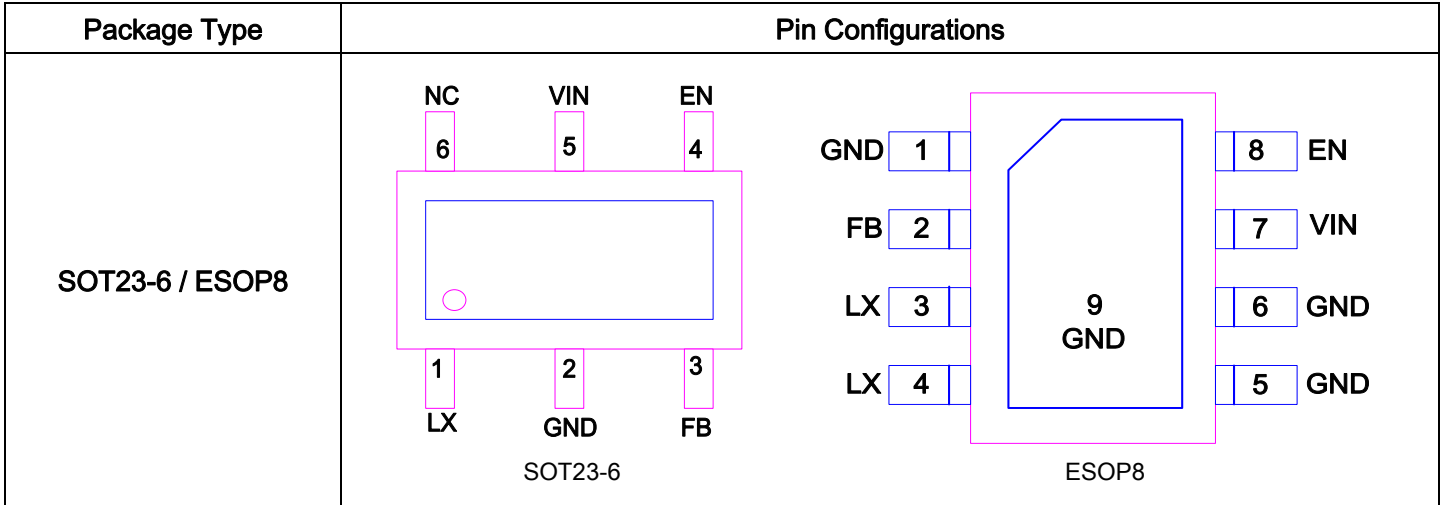

Pin		Name	Description
ESOP8	SOT23-6		
1	2	GND	Ground Pin.
2	3	FB	Feed back.
3	1	LX	Switching Pin.
4		LX	Switching Pin.
5	2	GND	Ground Pin.
6		GND	Ground Pin.
7	5	VIN	Voltage Input Pin.
8	4	EN	Chip Enable Pin.
	6	NC	No Connector.



Function Block Diagram

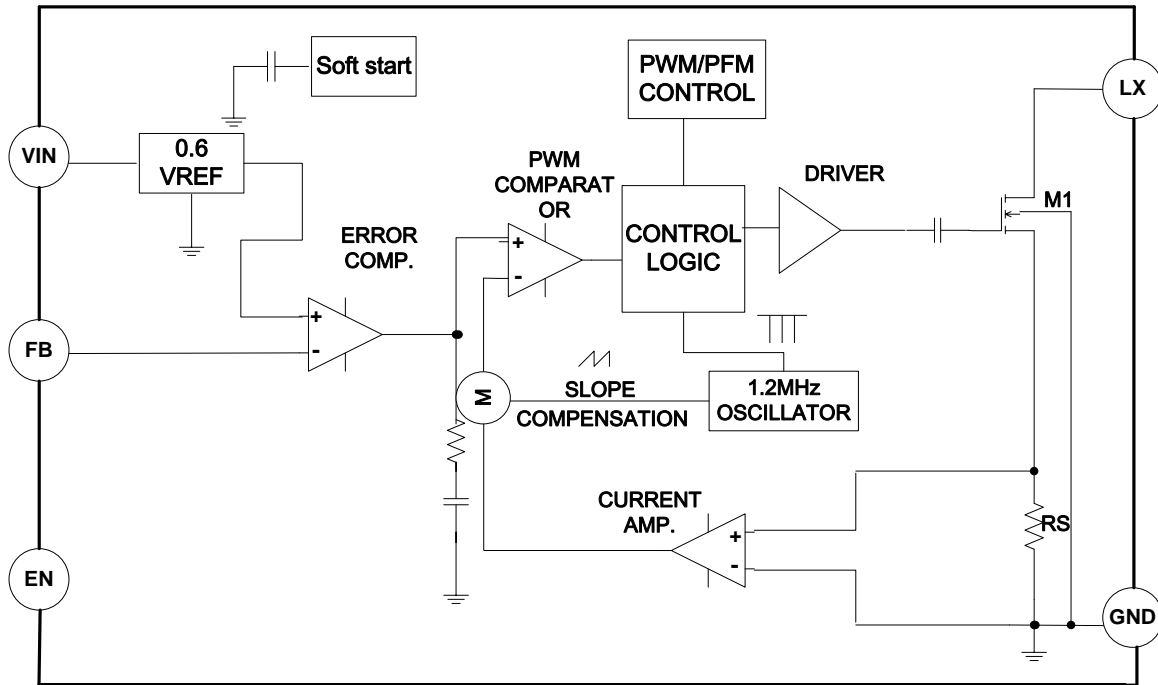

Absolute Maximum Ratings

- ✧ Supply Input Voltage ----- 6V
- ✧ LX Voltage to GND ----- 12V
- ✧ Other Pin Voltage to GND ----- 6V
- ✧ Maximum Junction Temperature ----- 150°C
- ✧ Maximum Soldering Temperature (at leads, 10 sec) ----- 260°C

Power Dissipation, PD @ TA = 25°C

- ✧ ESOP8 ----- 2W
- ✧ SOT23-6 ----- 450mW

Package Thermal Resistance

- ✧ ESOP8, θ_{JA} ----- 50°C/W
- ✧ SOT23-6, θ_{JA} ----- 250°C/W

Recommended Operating Conditions

- ✧ Supply Input Voltage ----- 2.2V to 5.5V
- ✧ Operation Ambient Temperature Range ----- -20°C to 85°C



Electrical Characteristics

($V_{IN}=3.4V, V_{OUT}=5V, C_{IN}=22\mu F, C_{OUT}=22\mu F, L=2.2\mu H$)

Parameter	Condition	Min	Typ	Max	Units
Output Voltage Range		2.5		8.3	V
Supply Current(Shutdown)	$V_{EN}=V_{OUT}=0V, V_{LX}=5V$			1	μA
Supply Current	$V_{FB}=0.7V$			150	μA
Feedback Voltage		0.588	0.6	0.612	V
Feedback Input Current	$V_{FB}=0.6V$			50	nA
Switching Frequency			1200		KHz
Maximum Duty Cycle		85		95	%
EN Input Low Voltage				0.4	V
EN Input High Voltage		1.4			V
Power MOSFET Current Limit	LP6212SPF	6			A
	LP6212B6F	4			A
High-side On Resistance	$V_{OUT}=3.3V$			100	m Ω

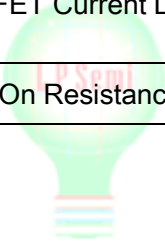



Typical Operating Characteristics

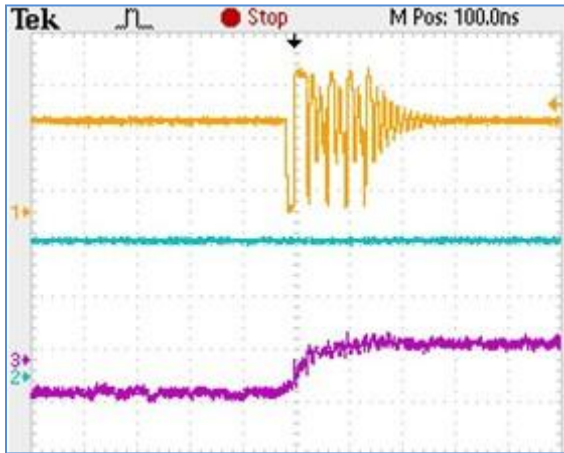

$V_{IN}=3.3V, V_{OUT}=5V, I_{OUT}=0mA$

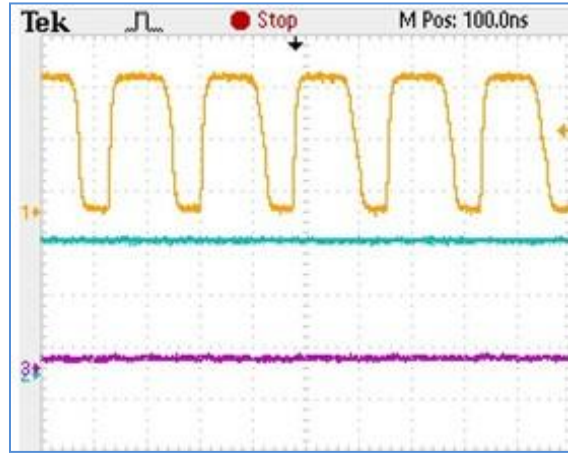

$V_{IN}=3.3V, V_{OUT}=5V, I_{OUT}=50mA$



$V_{IN}=3.3V, V_{OUT}=5V, I_{OUT}=100mA$



$V_{IN}=3.3V, V_{OUT}=5V, I_{OUT}=2A$

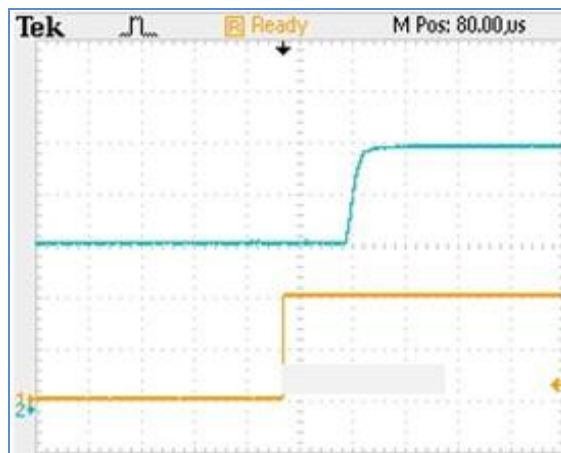

Delay time when EN is on IN

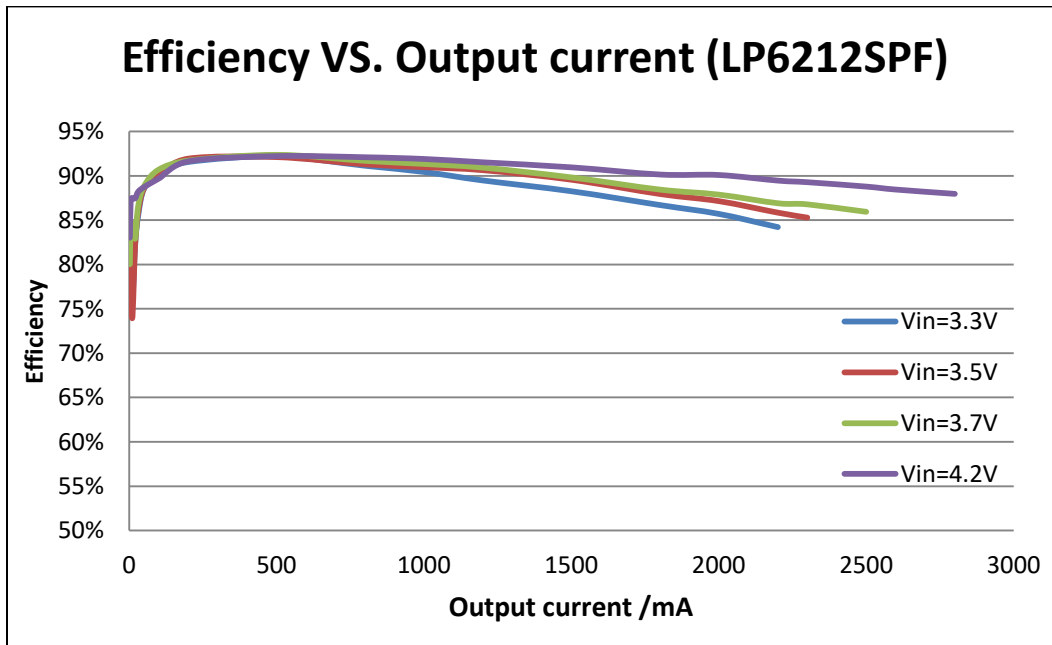
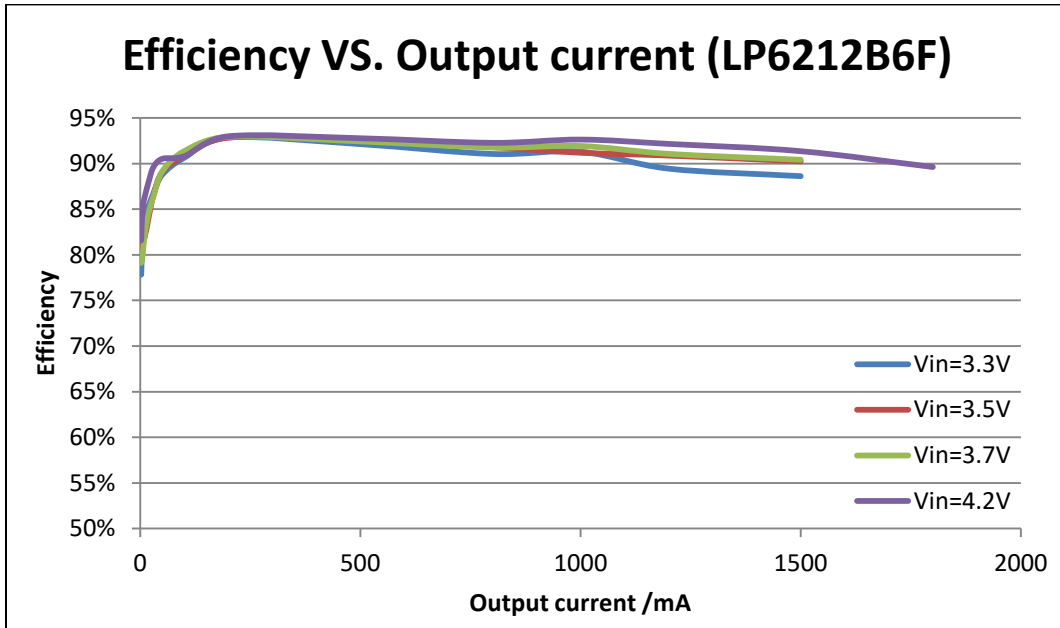



Operation Information

The LP6212 uses a fixed frequency, peak current mode boost regulator architecture to regulate voltage at the feedback pin. At the start of each oscillator cycle the MOSFET is turned on through the control circuitry. To prevent sub-harmonic oscillations at duty cycles greater than 50 percent, a stabilizing ramp is added to the output of the current sense amplifier and the result is fed into the negative input of the PWM comparator. When this voltage equals the output voltage of the error amplifier the power MOSFET is turned off. The voltage at the output of the error amplifier is an amplified version of the difference between the 0.6V bandgap reference voltage and the feedback voltage. In this way the peak current level keeps the output in regulation. If the feedback voltage starts to drop, the output of the error amplifier increases. These results in more current to flow through the power MOSFET, thus increasing the power delivered to the output. The LP6212 has internal soft start to limit the amount of input current at startup and to also limit the amount of overshoot on the output.

Setting the Output Voltage

Set the output voltage by selecting the resistive voltage divider ratio. The voltage divider drops the output voltage to the 0.6V feedback voltage. Use a 100K resistor for R_2 of the voltage divider. Determine the high-side resistor R_1 by the equation:

$$V_{OUT} = (R_1 / R_2 + 1) \times V_{FB}$$

$$V_{OUT} = (R_1 / R_2 + 1) \times 0.6V$$



Packaging Information

ESOP8

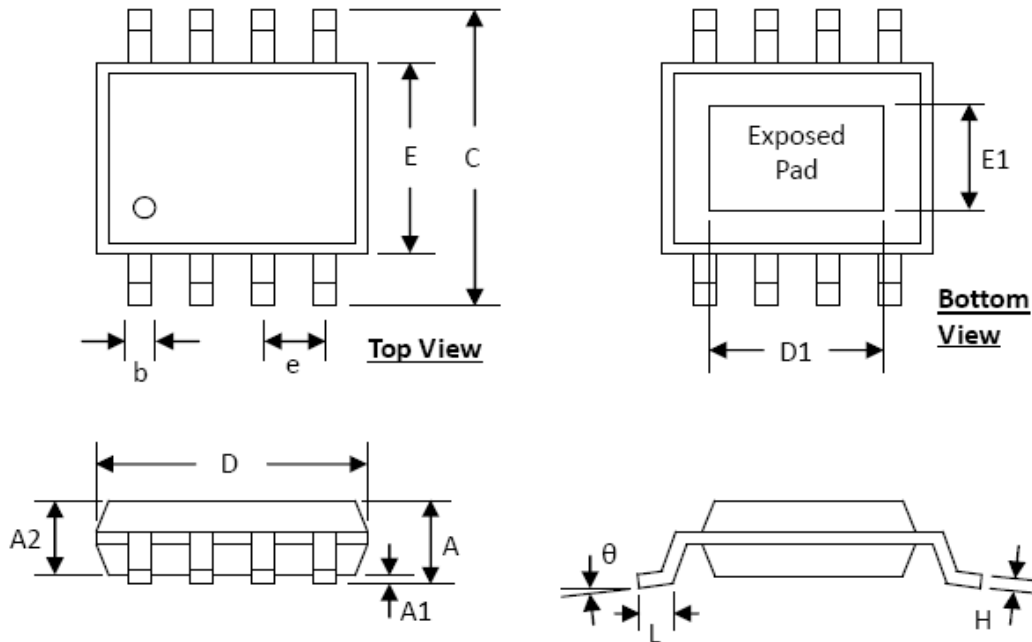

SYMBOLS	DIMENSION (MM)		DIMENSION (INCH)	
	MIN	MAX	MIN	MAX
A	1.30	1.70	0.051	0.067
A1	0.00	0.15	0.000	0.006
A2	1.25	1.52	0.049	0.060
b	0.33	0.51	0.013	0.020
C	5.80	6.20	0.228	0.244
D	4.80	5.00	0.189	0.197
D1	3.15	3.45	0.124	0.136
E	3.80	4.00	0.150	0.157
E1	2.26	2.56	0.089	0.101
e	1.27 BSC		0.050 BSC	
H	0.19	0.25	0.0075	0.0098
L	0.41	1.27	0.016	0.050
θ	0°	8°	0°	8°



SOT23-6

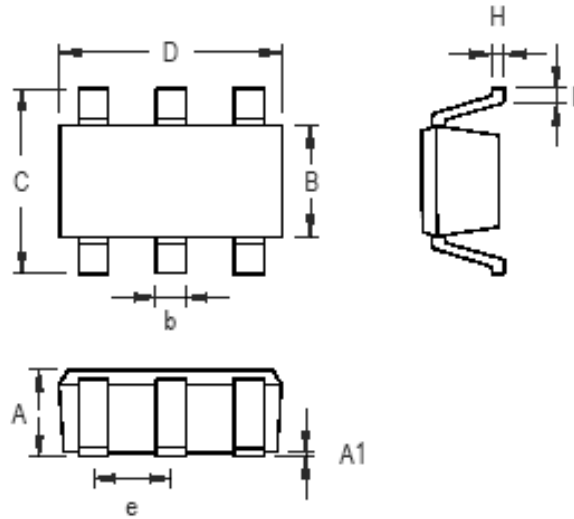

Symbol	Dimensions In Millimeters		Dimensions In Inches	
	Min	Max	Min	Max
A	0.889	1.295	0.031	0.051
A1	0.000	0.152	0.000	0.006
B	1.397	1.803	0.055	0.071
b	0.250	0.560	0.010	0.022
C	2.591	2.997	0.102	0.118
D	2.692	3.099	0.106	0.122
e	0.838	1.041	0.033	0.041
H	0.080	0.254	0.003	0.010
L	0.300	0.610	0.012	0.024

SOT-23-6 Surface Mount Package

单击下面可查看定价，库存，交付和生命周期等信息

[>>LOW POWER\(微源半导体\)](#)