



300mA, Ultra-low Noise LDO Regulator

General Description

The LP3986 is designed for portable applications with demanding performance and space requirements. The LP3986 performance is optimized for battery-powered systems to deliver ultra low noise and low quiescent current. Regulator ground current increases only slightly in dropout, further prolonging the battery life. The LP3986 also works with low-ESR ceramic capacitors, reducing the amount of board space necessary for power applications, critical in hand-held wireless devices. The other features include ultra low dropout voltage, high output accuracy, current limiting protection, and high ripple rejection ratio. Available in the 3-lead of SOT23-3 and SOT89-3 packages

Features

- ◆ Ultra-Low-Noise for RF Application
- ◆ 2.5V- 6V Input Voltage Range
- ◆ Low Dropout : 220mV @ 300mA
- ◆ Ultra-Fast Response in Line/Load Transient
- ◆ Current Limiting and Thermal Shutdown Protection

Applications

- ◇ PMP/PDA/MP3 players
- ◇ Cellular and Mobile phone
- ◇ RF Module
- ◇ Sensor Module

Typical Application Circuit

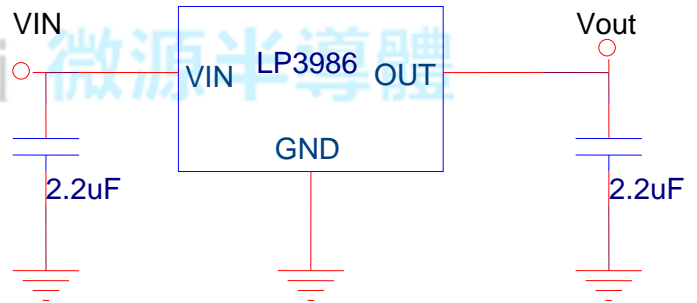

Order Information

LP3986	□ □ □ □ □	F: Pb-Free
		Package Type
		B3: SOT23-3
		X3: SOT89-3
		Output Type
		12: 1.2V
		15: 1.5V
		18: 1.8V
		25: 2.5V
		28: 2.8V
		30: 3.0V
		33: 3.3V
		36: 3.6V
		50: 5.0V

Marking Information

Device	Marking	Shipping
LP3986-15B3F	LPS 6NYWX	3K/REEL
LP3986-18B3F	LPS 6CYWX	
LP3986-33B3F	LPS 6EYWX	
LP3986-18X3F	LPS 6CYWX	

Marking indication:

Y: Year code .W: W is week code. X: X is series number.



Functional Pin Description

Package Type	Pin Configurations
SOT23	

Pin Description

Pin		Name	Description
SOT89-3	SOT23-3		
1	1	GND	Ground.
2	3	VIN	Power Input Pin.
3	2	OUT	Output Pin.

Function Diagram

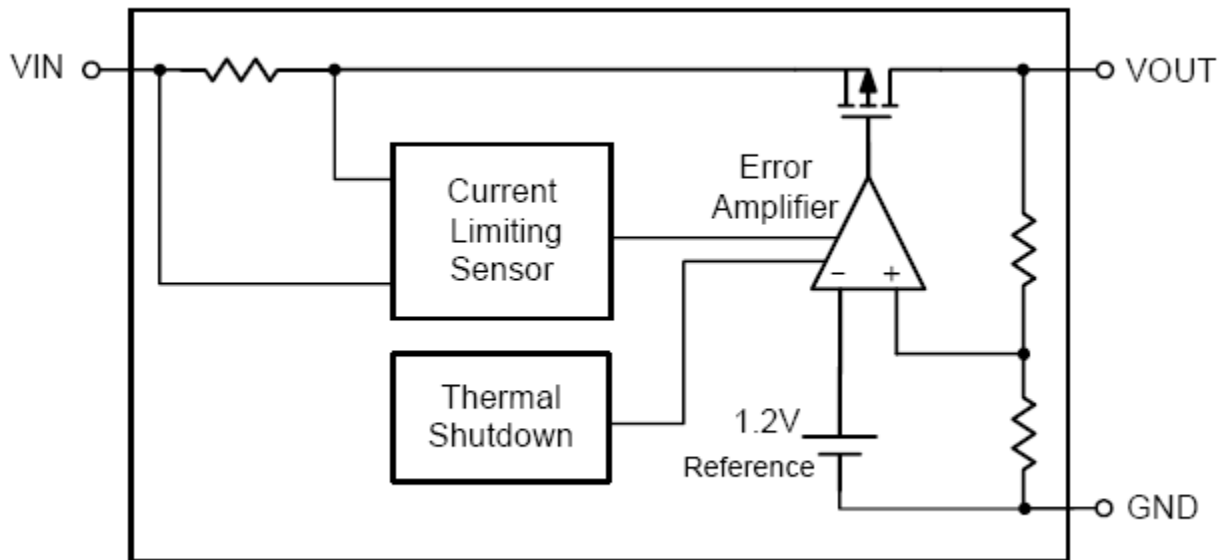



Absolute Maximum Ratings

- ◇ Supply Input Voltage ----- 7V
Power Dissipation, PD @ TA = 25°C
- ◇ SOT-23-3 ----- 350mW
- ◇ SOT89-3 ----- 550mW
Package Thermal Resistance
- ◇ SOT-23-3, θ_{JA} ----- 350°C/W
- ◇ SOT89-3, θ_{JA} ----- 180°C/W
- ◇ Lead Temperature (Soldering, 10 sec.) ----- 260°C
- ◇ Storage Temperature Range ----- -65°C to 165°C
- ESD Susceptibility
- ◇ HBM (Human Body Mode) ----- 2kV
- ◇ MM(Machine-Mode) ----- 200V
- Recommended Operating Conditions
- ◇ Supply Input Voltage ----- 2.5V to 6V
- ◇ Operation Junction Temperature Range ----- -40°C to 125°C
- ◇ Operation Ambient Temperature Range ----- -40°C to 85°C

Electrical Characteristics

(LP3986-33B3F, VIN = VOUT + 1V, CIN = COUT = 2.2μF, TA = 25° C, unless otherwise specified)

Parameter	Symbol	Test Conditions	Min	Typ.	Max	Units
Output Voltage Accuracy	ΔV_{OUT}	IOUT = 1mA	-3	--	+3	%
Output Voltage	VOUT	IOUT = 1mA		3.33		V
Current Limit	ILIM	RLOAD = 1Ω	350			mA
Quiescent Current	IQ	IOUT = 0mA, Vout=3.3V		75	130	μA
Dropout Voltage	VDROP	IOUT = 300mA, VOUT > 2.8V		220	300	mV
Line Regulation	ΔV_{LINE}	VIN = (VOUT + 1V) to 5.5V, IOUT = 1mA			0.2	%
Load Regulation	ΔV_{LOAD}	1mA < IOUT < 300mA			2	%
Power Supply Rejection Reat	PSRR	Iout=100mA F=1KHz		-76		dB
		Iout=100mA F=10KHz		-65		dB
Thermal Shutdown Temperature	TSD			150		°C
Thermal Shutdown Hysteresis				20		°C



Typical Operating Characteristics

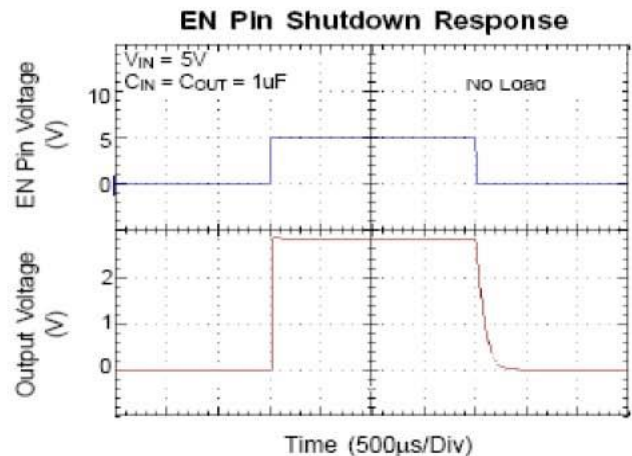
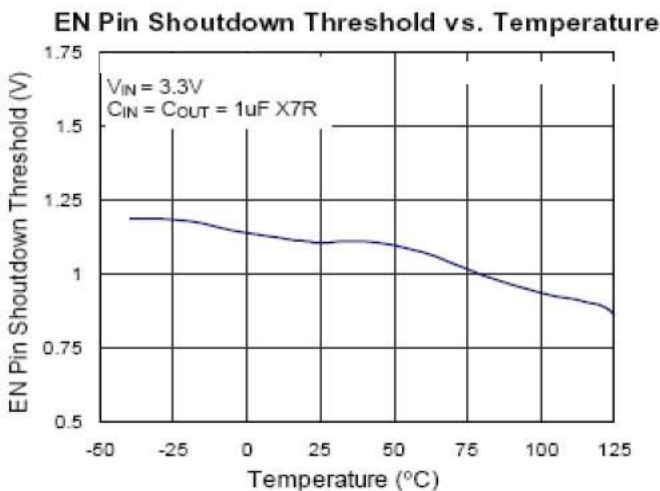
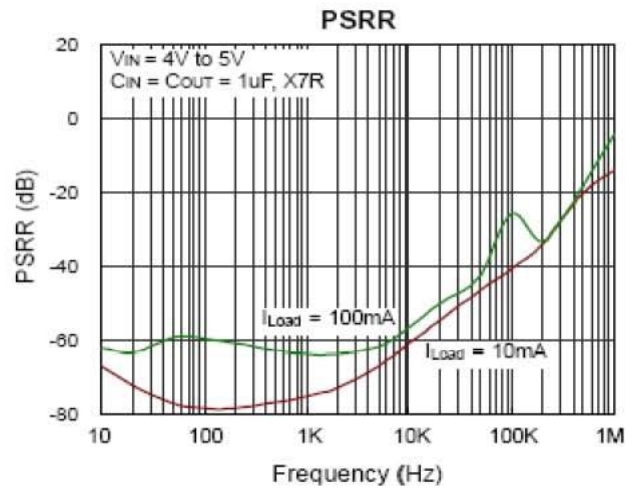
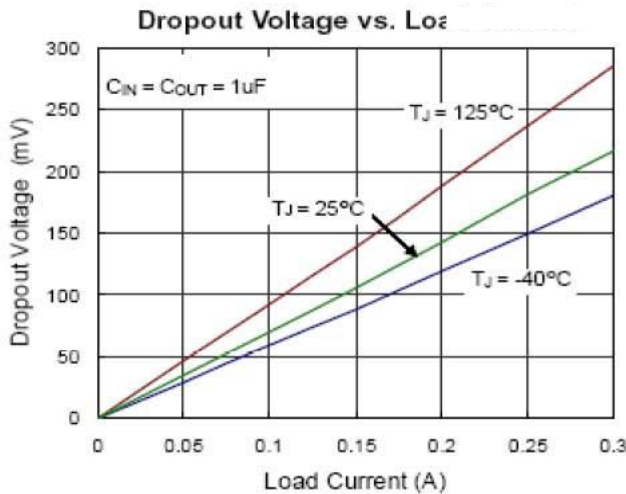
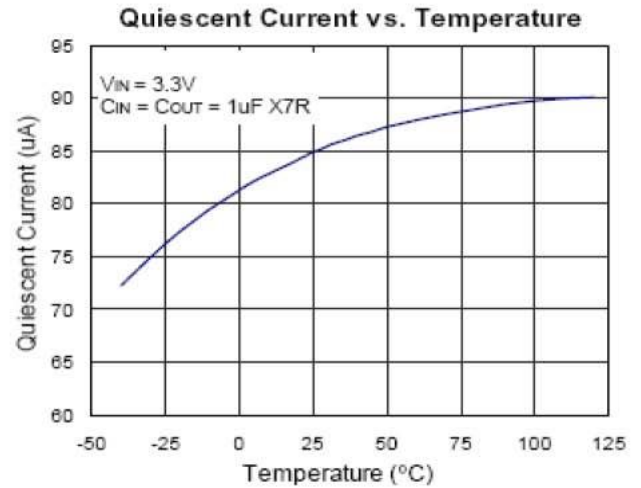
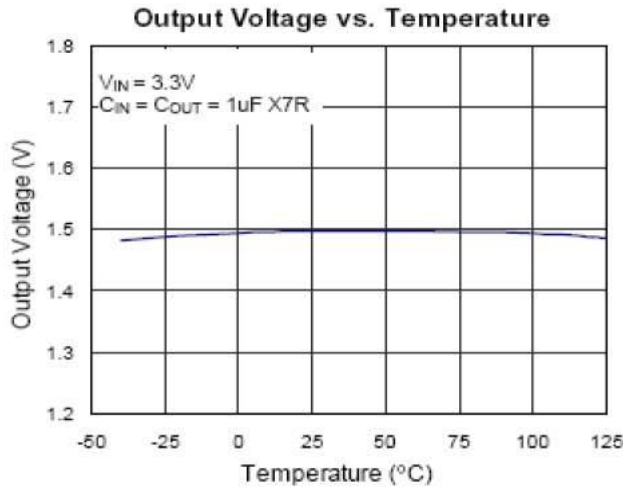



Load Transient Response

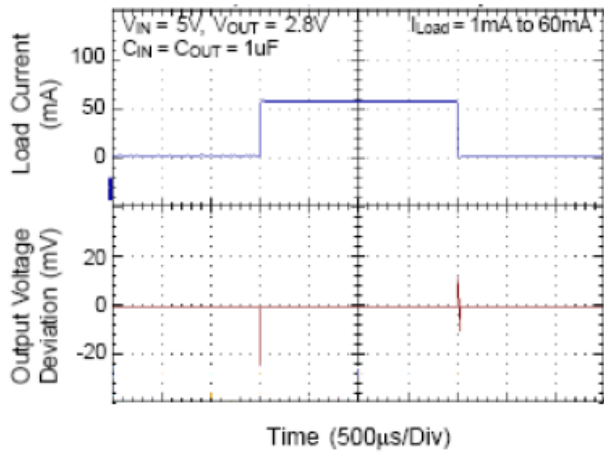

Load Transient Response

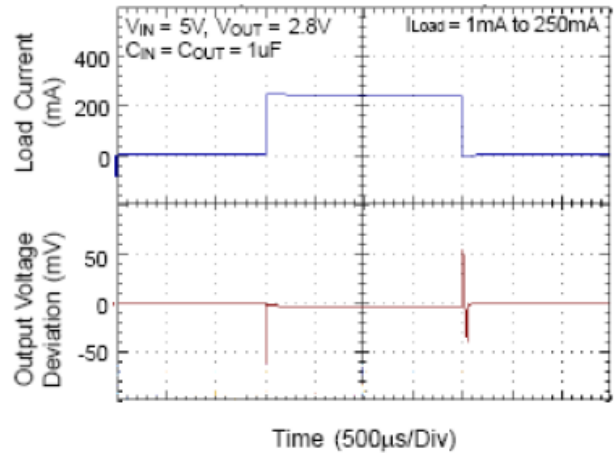

Line Transient Response

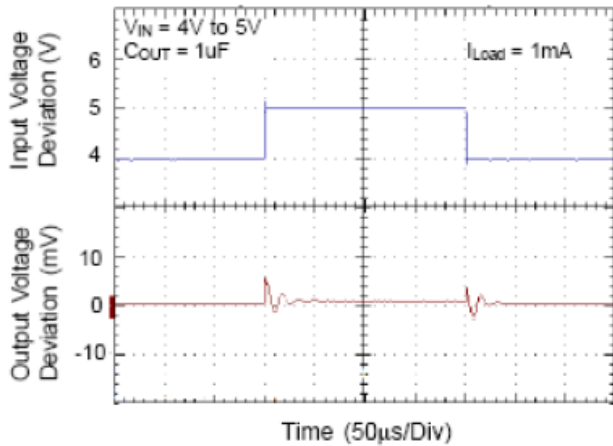

Line Transient Response

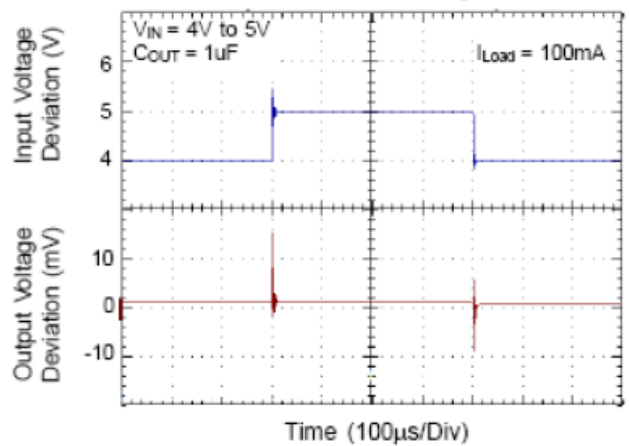



Applications Information

Thermal Considerations

Thermal protection limits power dissipation in LP3986. When the operation junction temperature exceeds 150°C, the OTP circuit starts the thermal shutdown function turn the pass element off. The pass element turns on again after the junction temperature cools by 25°C. For continue operation, do not exceed absolute maximum operation junction temperature 125°C.

The power dissipation definition in device is :

$$P_D = (V_{IN} - V_{OUT}) \times I_{OUT} + V_{IN} \times I_Q$$

The maximum power dissipation depends on the thermal resistance of IC package, PCB layout, the rate of surroundings airflow and temperature difference between junction to ambient.

The maximum power dissipation can be calculated by following formula :

$$P_{D(MAX)} = (T_{J(MAX)} - T_A) / \theta_{JA}$$

Where $T_{J(MAX)}$ is the maximum operation junction temperature 125°C, T_A is the ambient temperature and the θ_{JA} is the junction to ambient thermal resistance. For recommended operating conditions specification of LP3986, where $T_{J(MAX)}$ is the maximum junction temperature of the die

(125°C) and T_A is the maximum ambient temperature. The junction to ambient thermal resistance (θ_{JA} is layout dependent) for SOT89 package is 180°C/W.

$$P_{D(MAX)} = (125^\circ\text{C} - 25^\circ\text{C}) / 180^\circ\text{C} = 550\text{mW (SOT89)}$$

The maximum power dissipation depends on operating ambient temperature for fixed $T_{J(MAX)}$ and thermal resistance θ_{JA} . When considering the thermal characteristic of PCB it may be larger than 550mW.



Packaging Information

SOT23-3

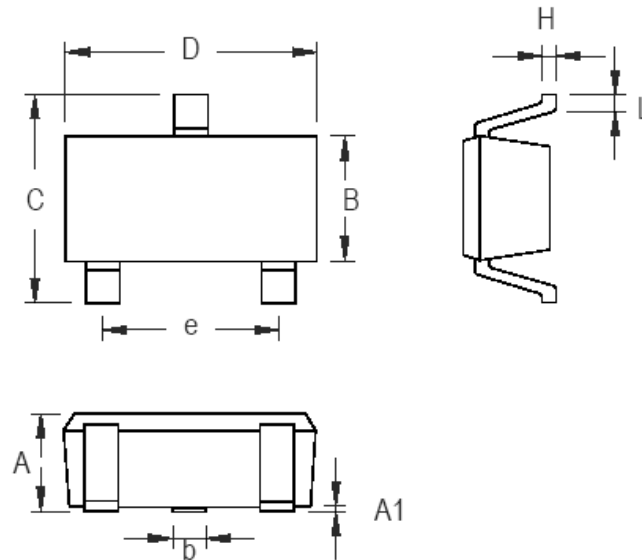

Symbol	Dimensions In Millimeters		Dimensions In Inches	
	Min	Max	Min	Max
A	0.889	1.295	0.035	0.051
A1	0.000	0.152	0.000	0.006
B	1.397	1.803	0.055	0.071
b	0.356	0.508	0.014	0.020
C	2.591	2.997	0.102	0.118
D	2.692	3.099	0.106	0.122
e	1.803	2.007	0.071	0.079
H	0.080	0.254	0.003	0.010
L	0.300	0.610	0.012	0.024

SOT-23 Surface Mount Package



SOT89-3

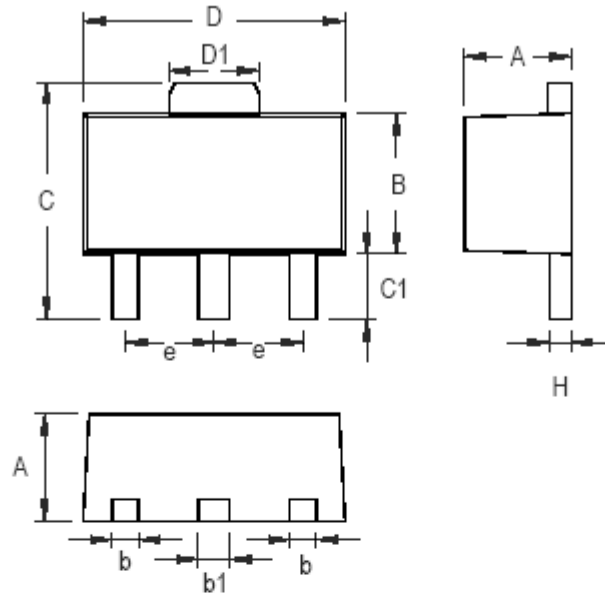

Symbol	Dimensions In Millimeters		Dimensions In Inches	
	Min	Max	Min	Max
A	1.397	1.600	0.055	0.063
b	0.356	0.483	0.014	0.019
B	2.388	2.591	0.094	0.102
b1	0.406	0.533	0.016	0.021
C	3.937	4.242	0.155	0.167
C1	0.787	1.194	0.031	0.047
D	4.394	4.597	0.173	0.181
D1	1.397	1.753	0.055	0.069
e	1.448	1.549	0.057	0.061
H	0.356	0.432	0.014	0.017

3-Lead SOT-89 Surface Mount Package

单击下面可查看定价，库存，交付和生命周期等信息

[>>LOW POWER\(微源半导体\)](#)