



## 200mA, Ultra-low Noise LDO Regulator

### General Description

The LP3995 is designed for portable applications with demanding performance and space requirements. The LP3995 performance is optimized for high voltage systems to deliver ultra low noise and low quiescent current. Regulator ground current increases only slightly in dropout, further prolonging the input system life. The LP3995 also works with low-ESR ceramic capacitors, reducing the amount of board space necessary for power applications, critical in hand-held wireless devices. The other features include ultra low dropout voltage, high output accuracy, current limiting protection, and high ripple rejection ratio.

### Features

- ◆ Ultra-Low-Noise for RF Application
- ◆ Input Voltage up to 35V
- ◆ Low Dropout : 600mV @ 100mA
- ◆ Output Current  $\geq 200\text{mA}$
- ◆ Ultra-Fast Response in Line/Load Transient
- ◆ Current Limiting and Thermal Shutdown Protection

### Applications

- ◇ PMP/PDA/MP3 players
- ◇ Cellular and Mobile phone
- ◇ RF Module
- ◇ Sensor Module

### Order Information

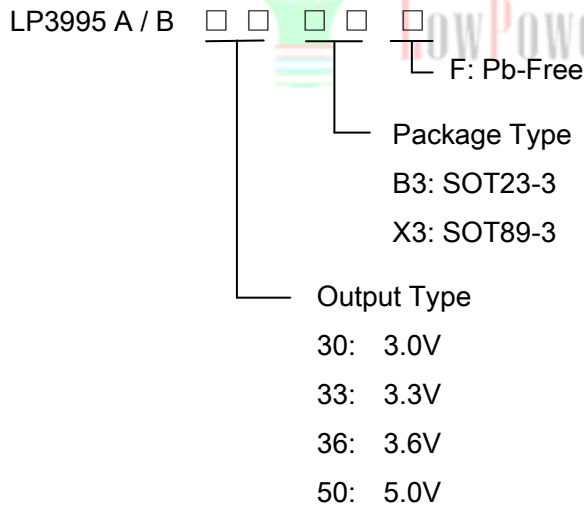

### Typical Application Circuit

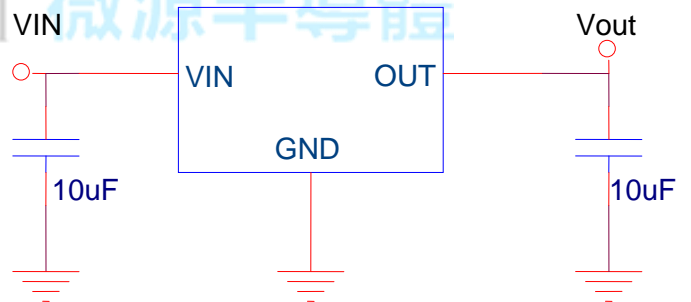

### Marking Information

Device	Marking	Package	Shipping
LP3995AB3F	XXYW X	SOT23	3K/REEL
LP3995BB3F			
LP3995AX3F	XXYW X	SOT89	1K/REEL
LP3995BX3F			

Y: Year code .W: W is week code. X: X is series number.



### Functional Pin Description

Package Type	Pin Configurations
SOT-23-3 / SOT89-3	

### Pin Description

Pin				Name	Description
SOT89		SOT23			
LP3995A	LP3995B	LP3995A	LP3995B		
1	2	1	3	GND	Ground.
2	3	3	2	Vin	Power Input Pin
3	1	2	1	Vout	Output Pin.

### Function Diagram

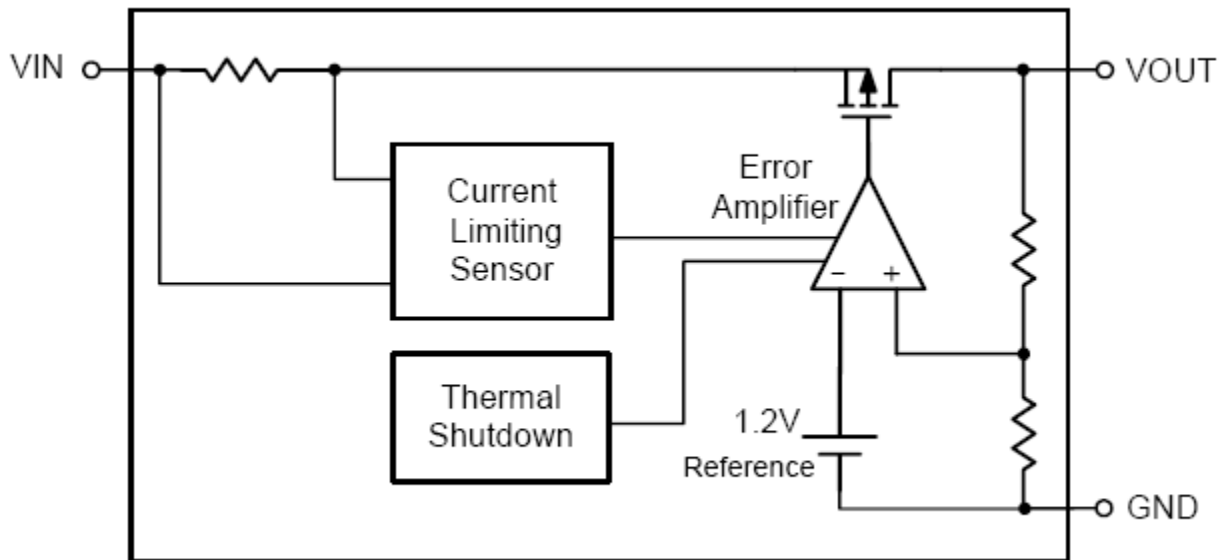



## Absolute Maximum Ratings

- ◇ Supply Input Voltage ----- -0.3V to 35V  
Power Dissipation, PD @ TA = 25°C
- ◇ SOT23-3 ----- 450mW
- ◇ SOT89-3 ----- 700mW
- ◇ Lead Temperature (Soldering, 10 sec.) ----- 260°C
- ◇ Storage Temperature Range ----- -65°C to 150°C  
Package Thermal Resistance
- ◇ SOT23-3,  $\theta_{JA}$  ----- 250°C/W
- ◇ SOT89-3,  $\theta_{JA}$  ----- 165°C/W  
ESD Susceptibility
- ◇ HBM (Human Body Mode) ----- 2kV
- ◇ MM(Machine-Mode) ----- 200V  
Recommended Operating Conditions
- ◇ Supply Input Voltage ----- Vout+1V to 30V
- ◇ Operation Junction Temperature Range ----- -20°C to 125°C
- ◇ Operation Ambient Temperature Range ----- -20°C to 85°C

## Electrical Characteristics

(VIN = 5V, CIN = 2.2 $\mu$ F, COUT = 10 $\mu$ F, TA = 25° C, unless otherwise specified)

Parameter	Symbol	Test Conditions	Min	Typ.	Max	Units
Output Voltage Accuracy	$\Delta V_{OUT}$	IOUT = 1mA	-2	--	+2	%
Current Limit	ILIM	RLOAD = 1 $\Omega$	220			mA
Quiescent Current	IQ	IOUT = 0mA		3		$\mu$ A
Dropout Voltage	VDROP	IOUT = 10mA, VOUT = 3.3V		60	70	mV
		IOUT = 100mA, VOUT = 3.3V		600	700	
		IOUT = 200mA, VOUT = 3.3V		1200	1400	
Linear Regulation	$\Delta V_{LINE}$	VIN = (VOUT + 1V) to 12V, IOUT = 1mA			0.2	%
Load Regulation	$\Delta V_{LOAD}$	1mA < IOUT < 200mA			2	%
Thermal Shutdown Temperature	TSD			150		°C
Thermal Shutdown Hysteresis				25		°C



### Typical Operating Characteristics

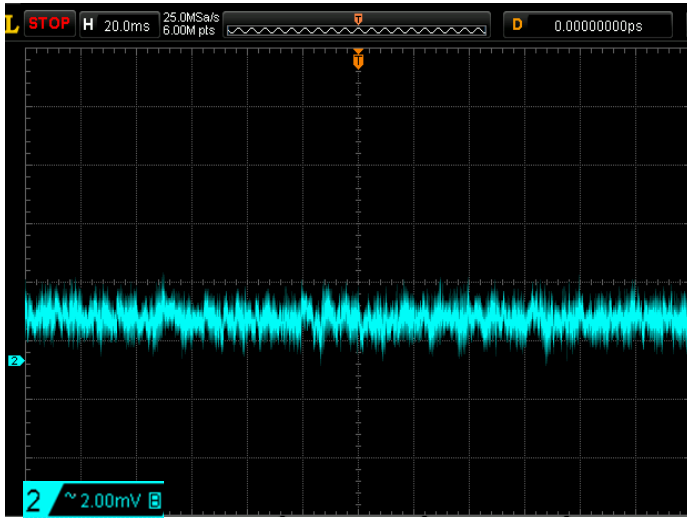

$\Delta V_{out}$  Waveform , $I_{out}=1mA$  , $V_{IN}=5V$  , $V_{out}=3.3V$

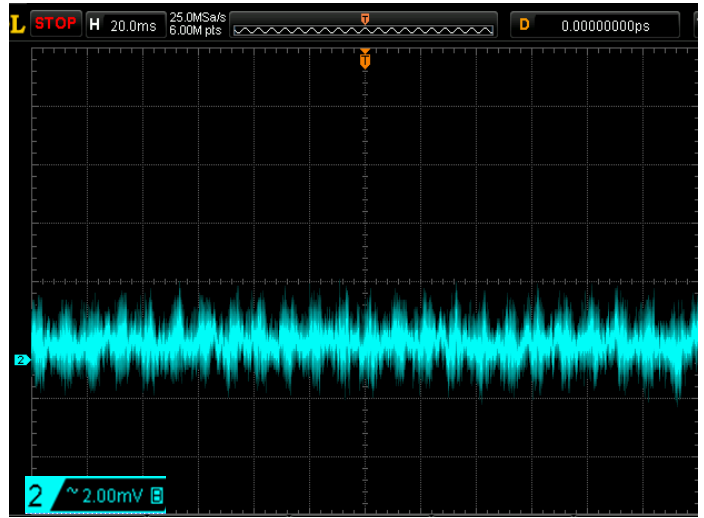

$\Delta V_{out}$  Waveform , $I_{out}=200mA$  , $V_{IN}=5V$  , $V_{out}=3.3V$

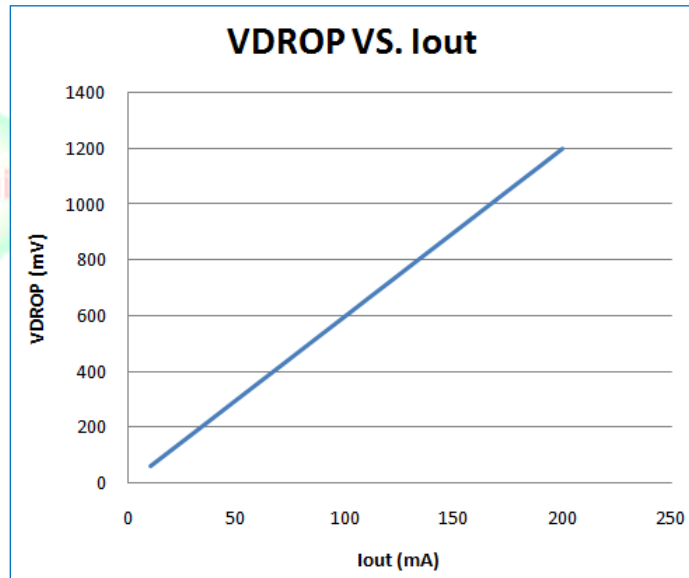

尊體



## Applications Information

Like any low-dropout regulator, the external capacitors used with the LP3995 must be carefully selected for regulator stability and performance. Using a capacitor whose value is  $\geq 10\mu\text{F}$  on the LP3995 input. The input capacitor must be located a distance of not more than 0.5 inch from the input pin of the IC and returned to a clean analog ground. Any good quality ceramic or tantalum can be used for this capacitor. The capacitor with larger value and lower ESR (equivalent series resistance) provides better PSRR and line-transient response. The output capacitor must meet both requirements for minimum amount of capacitance and ESR in all LDO's application. The LP3995 is designed specifically to work with low ESR ceramic output capacitor in space-saving and performance consideration. Using a ceramic capacitor whose value is at least  $10\mu\text{F}$  with ESR is  $> 25\text{m}\Omega$  on the LP3995 output ensures stability. The LP3995 still works well with output capacitor of other types due to the wide stable ESR range. Output capacitor of larger capacitance can reduce noise and improve load transient response, stability, and PSRR. The output capacitor should be located not more than 0.5 inch from the  $V_{\text{OUT}}$  pin of the LP3995 and returned to a clean analog ground.

### Thermal Considerations

Thermal protection limits power dissipation in LP3995. When the operation junction temperature exceeds  $150^\circ\text{C}$ , the OTP circuit starts the thermal shutdown function turn the pass element off. The pass element turns on again after the junction temperature cools by  $25^\circ\text{C}$ . For continue operation, do not exceed absolute maximum operation junction temperature  $125^\circ\text{C}$ .

The power dissipation definition in device is:

$$P_D = (V_{\text{IN}} - V_{\text{OUT}}) \times I_{\text{OUT}} + V_{\text{IN}} \times I_Q$$

The maximum power dissipation depends on the thermal resistance of IC package, PCB layout, the rate of surroundings airflow and temperature difference between junction and ambient.

The maximum power dissipation can be calculated by following formula:

$$P_{D(\text{MAX})} = (T_{J(\text{MAX})} - T_A) / \theta_{JA}$$

Where  $T_{J(\text{MAX})}$  is the maximum operation junction temperature  $125^\circ\text{C}$ ,  $T_A$  is the ambient temperature and the  $\theta_{JA}$  is the junction to ambient thermal resistance. For recommended operating conditions specification of LP3995, the junction to ambient thermal resistance ( $\theta_{JA}$  is layout dependent) for LP3995 showed below.

$$\text{SOT23-3 : } 250^\circ\text{C/W}$$

$$\text{SOT89-3 : } 165^\circ\text{C/W}$$

And ,

$$P_D = (125^\circ\text{C} - 25^\circ\text{C}) / 250^\circ\text{C/W} = 400\text{mW (SOT23-3)}$$

$$P_D = (125^\circ\text{C} - 25^\circ\text{C}) / 165^\circ\text{C/W} = 600\text{mW (SOT89-3)}$$

The maximum power dissipation depends on operating ambient temperature for fixed  $T_{J(\text{MAX})}$  and thermal resistance  $\theta_{JA}$ .



### Packaging Information

#### SOT-89

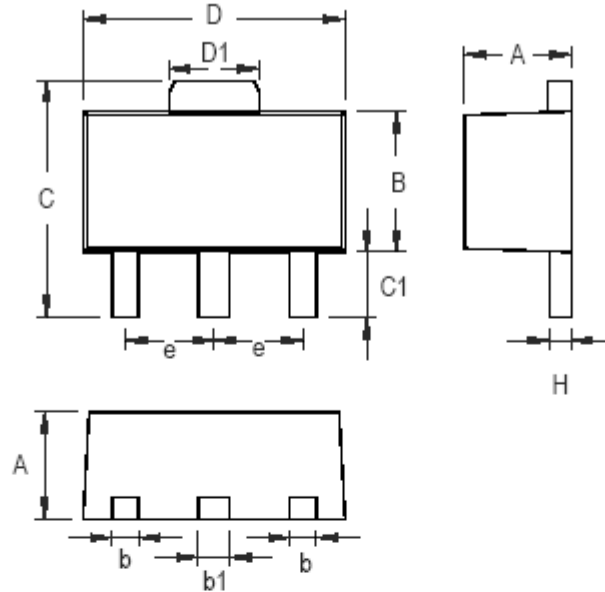

Symbol	Dimensions In Millimeters		Dimensions In Inches	
	Min	Max	Min	Max
A	1.397	1.600	0.055	0.063
b	0.356	0.483	0.014	0.019
B	2.388	2.591	0.094	0.102
b1	0.406	0.533	0.016	0.021
C	3.937	4.242	0.155	0.167
C1	0.787	1.194	0.031	0.047
D	4.394	4.597	0.173	0.181
D1	1.397	1.753	0.055	0.069
e	1.448	1.549	0.057	0.061
H	0.356	0.432	0.014	0.017

3-Lead SOT-89 Surface Mount Package



SOT23-3

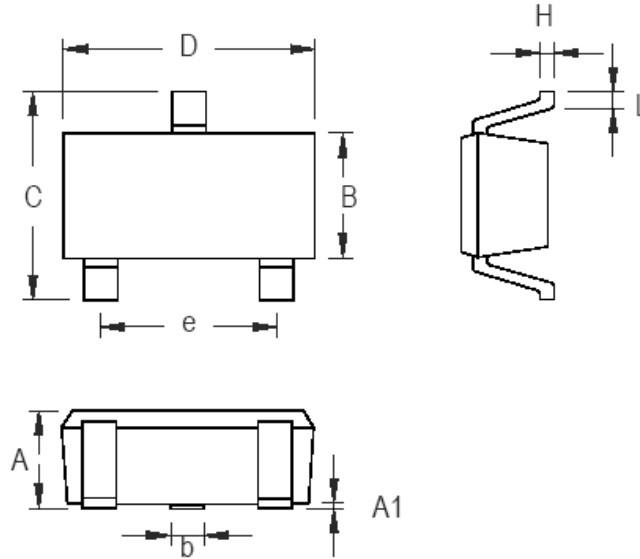

Symbol	Dimensions In Millimeters		Dimensions In Inches	
	Min	Max	Min	Max
A	0.889	1.295	0.035	0.051
A1	0.000	0.152	0.000	0.006
B	1.397	1.803	0.055	0.071
b	0.356	0.508	0.014	0.020
C	2.591	2.997	0.102	0.118
D	2.692	3.099	0.106	0.122
e	1.803	2.007	0.071	0.079
H	0.080	0.254	0.003	0.010
L	0.300	0.610	0.012	0.024

SOT-23 Surface Mount Package

单击下面可查看定价，库存，交付和生命周期等信息

[>>LOW POWER\(微源半导体\)](#)