



Reset, Low Voltage Detector Built-in Delay 240mS

General Description

LP3809 is a series of high precision voltage detector with ultra low current consumption. It can work at very low voltage, which makes it perfect for system reset.

LP3809 is composed of high precision voltage reference, comparator, delay circuit, output driver and resistor array. Internally preset detect voltage has a low temperature drift and requires no external trimming.

LP3809 is available in SOT-23-3 packages which are Pb free.

Features

- ◆ High-precision detection Voltage 2%
- ◆ Detection Voltage 0.9V~5.5V (in 0.1V steps)
- ◆ Precise hysteresis 4% typ.
- ◆ Operating Voltage range 0.9V~5.5V

Applications

- ◇ Power monitor for portable equipment
- ◇ PDA, DSC, Mobile phone, Notebook, MP3
- ◇ CPU and Logic Circuit Reset
- ◇ Battery Checker
- ◇ Battery Back-up Circuit
- ◇ Power Failure Detector

Order Information

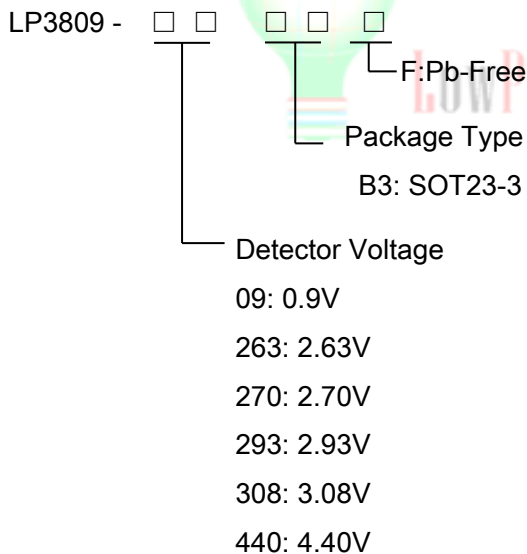

Marking Information

Device	Marking	Package	Shipping
LP3809-263B3F	LPS AFYW	SOT23-3	3K/REEL
LP3809-293B3F	LPS ADYW	SOT23-3	3K/REEL
Marking indication: Y: Production year W: Production week			

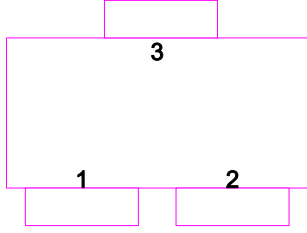

Pin Assignment

Package Type	Pin Configurations
SOT23-3	

Pin Description

Pin Number	Pin Name	Function
1	VSS	GND pin.
2	Vout	Voltage detection output pin.
3	VDD	Voltage input pin.

Block Diagram

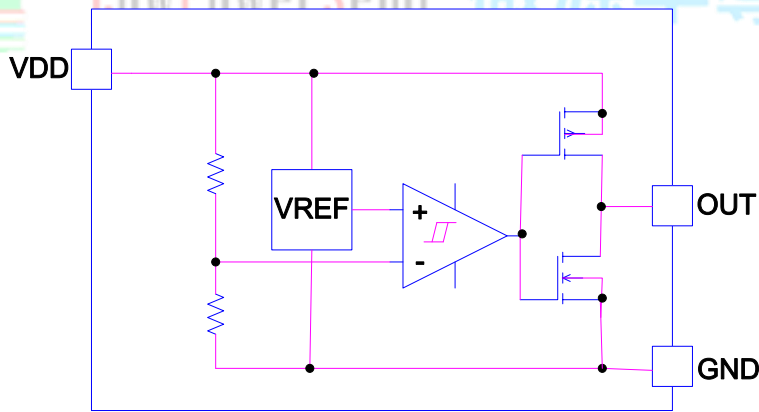



Absolute Maximum Ratings

- ◇ Input Voltage range ----- -0.3V~6V
- ◇ Output Voltage range ----- -0.3V~6V
- ◇ Maximum Output current ----- 60mA
- ◇ Maximum power dissipation ----- 150mW
- ◇ Ambient temperature ----- -40~+85°C
- ◇ Storage temperature ----- -40~125°C
- ◇ Lead temperature and time ----- 260°C,10S

Electrical Characteristics

(T=25°C, Unless otherwise specified.)

Symbol	Parameter	Conditions	Reference data			Unit
			Min.	Typ.	Max.	
VDET	Detector Threshold	LP3809-263B3F		2.63		V
		LP3809-293B3F		2.93		
ΔVDET	Voltage Accuracy		-3	---	+3	%
VHYS	Detector Threshold Hysteresis			0.108		V
IQ				4	7	uA
VDDH	Maximum operating voltage				5.5	V
VDDL	Minimum Operating voltage		0.9			V
IOUT	Output current	Nch VDS=0.05V VDD=0.7V	0.01	0.05		mA
		Pch VDS=-1V VDD=4.50V		33		mA
TDELAY	Output Delay Time			240		mS



Typical Electrical Characteristics

1) Supply current VS. Input voltage

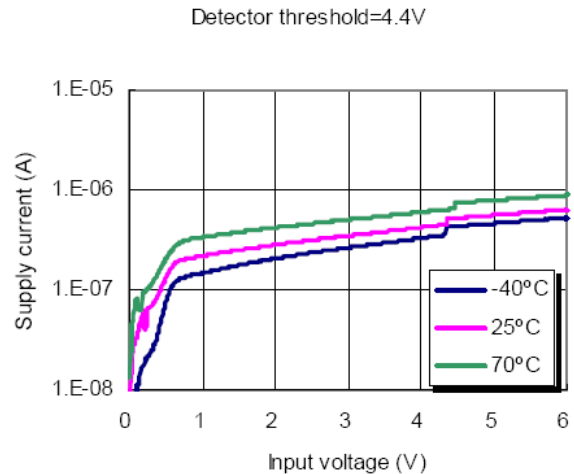
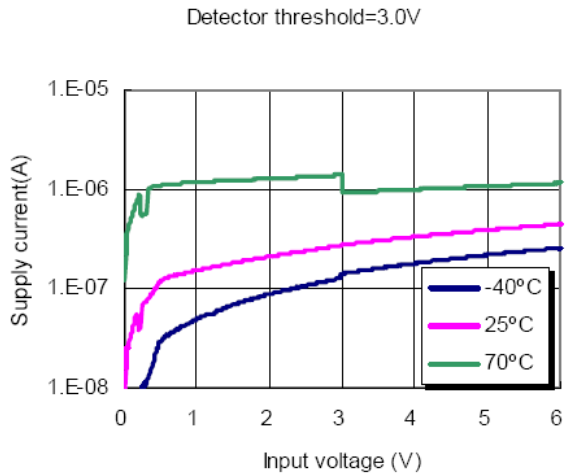
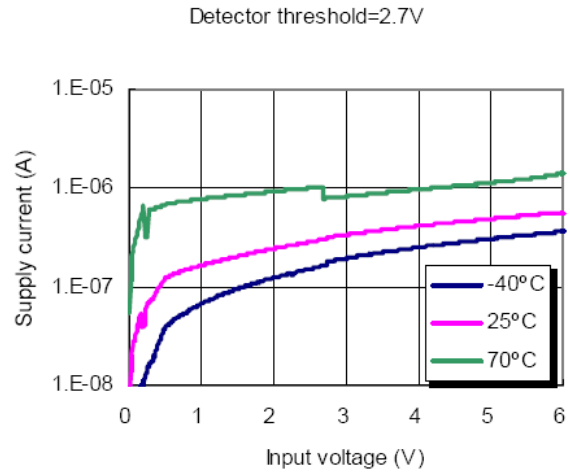
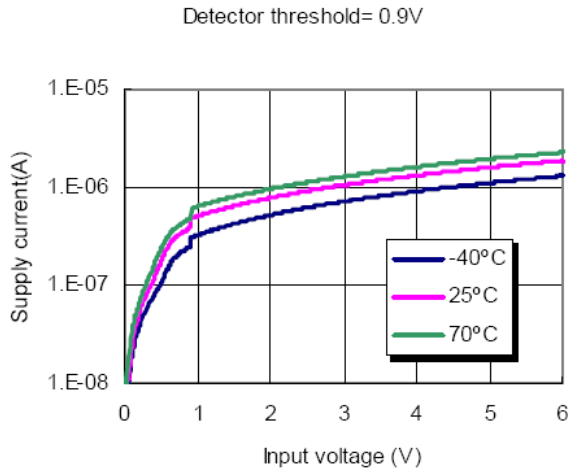



2) Detector Threshold VS. Temperature

Detector threshold= 0.9V

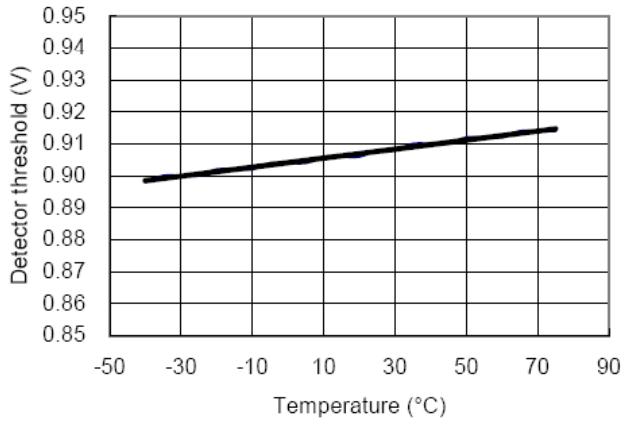

Detector threshold=2.7V

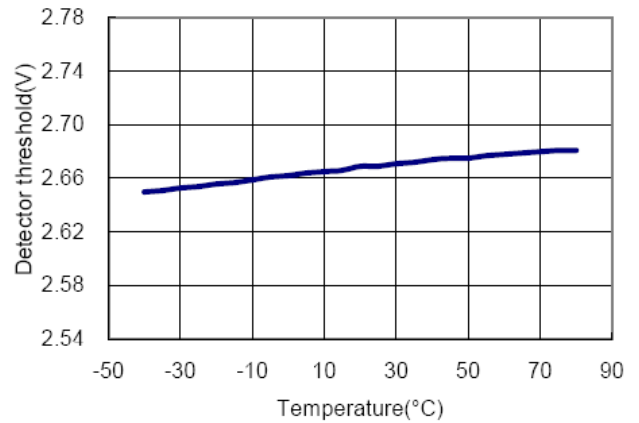

Detector threshold=3.0V

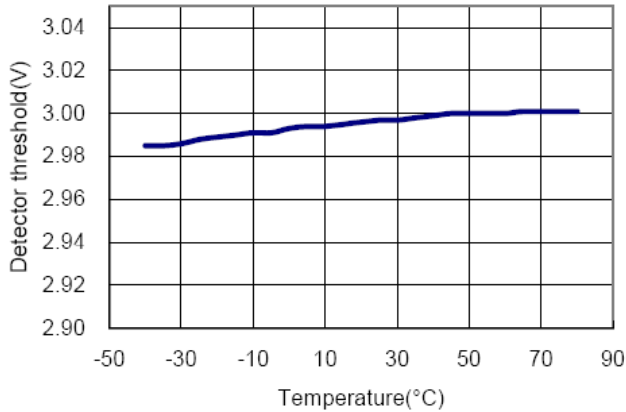

Detector threshold=4.4V

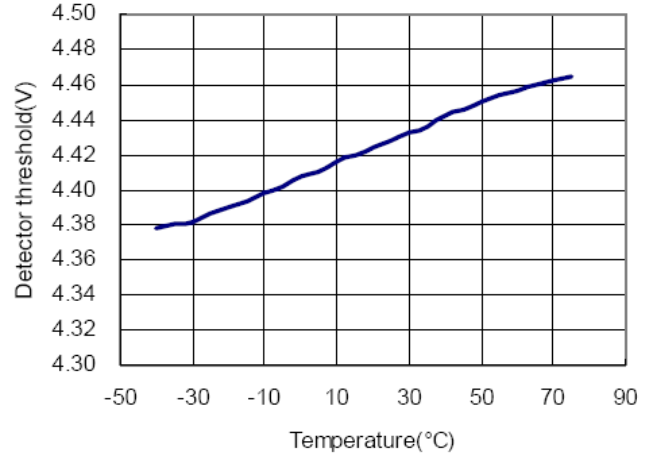



Packaging Information

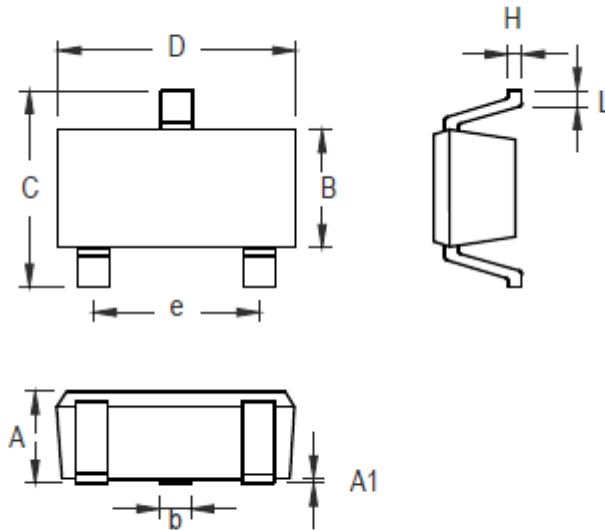

Symbol	Dim in millimeter	
	Min	Max
A	0.9	1.1
A1	0	0.1
B	1.25	1.35
b	0.35	0.5
C	2.25	2.55
D	2.8	3.0
e	1.8	2.0
H	0.09	0.15
L	0.2	0.45

单击下面可查看定价，库存，交付和生命周期等信息

[>>LOW POWER\(微源半导体\)](#)