

LBC848CLT1G

S-LBC848CLT1G

General Purpose Transistors NPN Silicon

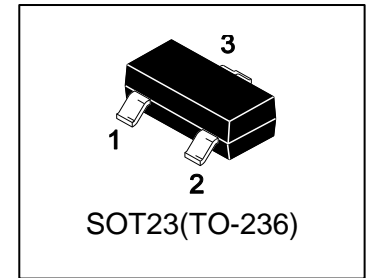

1. FEATURES

- Moisture Sensitivity Level: 1
- ESD Rating – Human Body Model: >4000 V
– Machine Model: >400 V
- We declare that the material of product compliance with RoHS requirements and Halogen Free.
- S-prefix for automotive and other applications requiring unique site and control change requirements; AEC-Q101 qualified and PPAP capable.

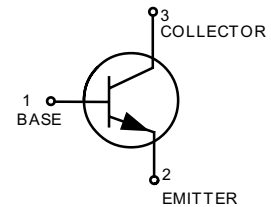

2. DEVICE MARKING AND ORDERING INFORMATION

Device	Marking	Shipping
LBC848CLT1G	1L	3000/Tape&Reel
LBC848CLT3G	1L	10000/Tape&Reel

3. MAXIMUM RATINGS(Ta = 25°C)

Parameter	Symbol	Limits	Unit
Collector–Emitter Voltage	V _{CEO}	30	V
Collector–Base Voltage	V _{CBO}	30	V
Emitter–Base Voltage	V _{EB0}	5	V
Collector Current — Continuous	I _C	100	mA

4. THERMAL CHARACTERISTICS

Parameter	Symbol	Limits	Unit
Total Device Dissipation, FR-5 Board (Note 1) @ TA = 25°C Derate above 25°C	PD	225 1.8	mW mW/°C
Thermal Resistance, Junction–to–Ambient(Note 1)	R _{θJA}	556	°C/W
Junction and Storage temperature	T _J , T _{stg}	-55~+150	°C

1. FR-5 = 1.0×0.75×0.062 in.

5. ELECTRICAL CHARACTERISTICS (Ta= 25°C)

OFF CHARACTERISTICS

Characteristic	Symbol	Min.	Typ.	Max.	Unit
Collector–Emitter Breakdown Voltage (IC = 10 mA)	VBR(CEO)	30	-	-	V
Collector–Emitter Breakdown Voltage (IC = 10 μA, VEB = 0)	VBR(CES)	30	-	-	V
Collector–Base Breakdown Voltage (IC = 10 μA)	VBR(CBO)	30	-	-	V
Emitter–Base Breakdown Voltage (IE = 1.0 μA)	VBR(EBO)	5	-	-	V
Collector Cutoff Current (VCB = 30 V)	ICBO	-	-	15	nA
(VCB = 30 V, TA = 150°C)		-	-	5	μA
Collector-Emitter cutoff Current (VCE=30V, IB=0)	ICEO	-	-	10	μA

ON CHARACTERISTICS

DC Current Gain (IC = 2.0 mA, VCE = 5.0 V)	HFE	420	520	800	
Collector–Emitter Saturation Voltage (IC = 10 mA, IB = 0.5 mA)	VCE(sat)	-	-	0.25	V
(IC = 100 mA, IB = 5.0 mA)		-	-	0.6	
Base–Emitter Saturation Voltage (IC = 10 mA, IB = 0.5 mA)	VBE(sat)	-	0.7	-	V
(IC = 100 mA, IB = 5.0 mA)		-	0.9	-	
Base–Emitter Voltage (IC = 2.0 mA, VCE = 5.0 V)	VBE(on)	580	660	700	mV
(IC = 10 mA, VCE = 5.0 V)		-	-	770	

SMALL–SIGNAL CHARACTERISTICS

Current–Gain — Bandwidth Product (IC = 10 mA, VCE = 5.0 V, f = 100 MHz)	fT	100	-	-	MHz
Output Capacitance (VCB = 10 V, f = 1.0 MHz)	Cobo	-	-	4.5	pF
Noise Figure (IC = 0.2 mA, VCE = 5.0 V, RS = 2.0 kΩ f = 1.0 kHz, BW = 200 Hz)	NF	-	-	10	dB

6.ELECTRICAL CHARACTERISTICS CURVES

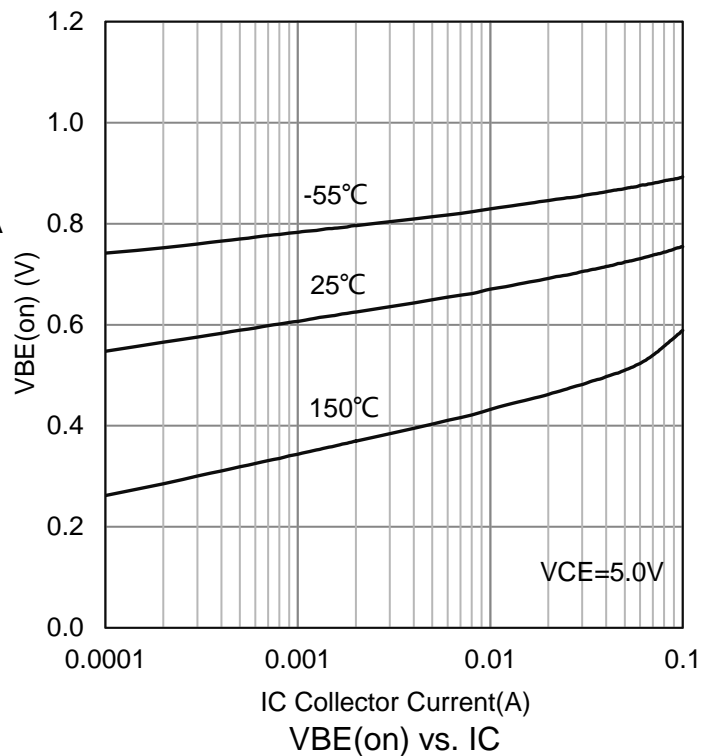
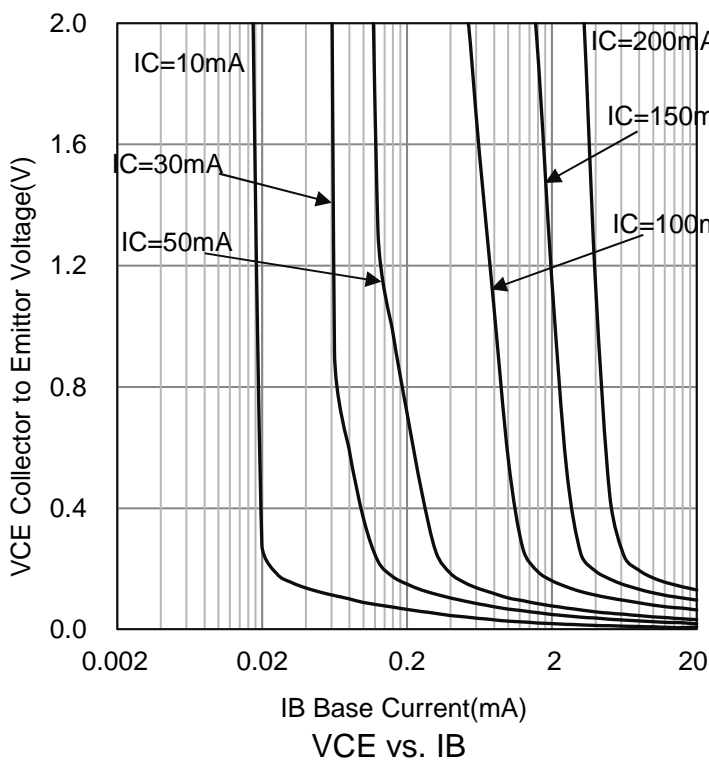
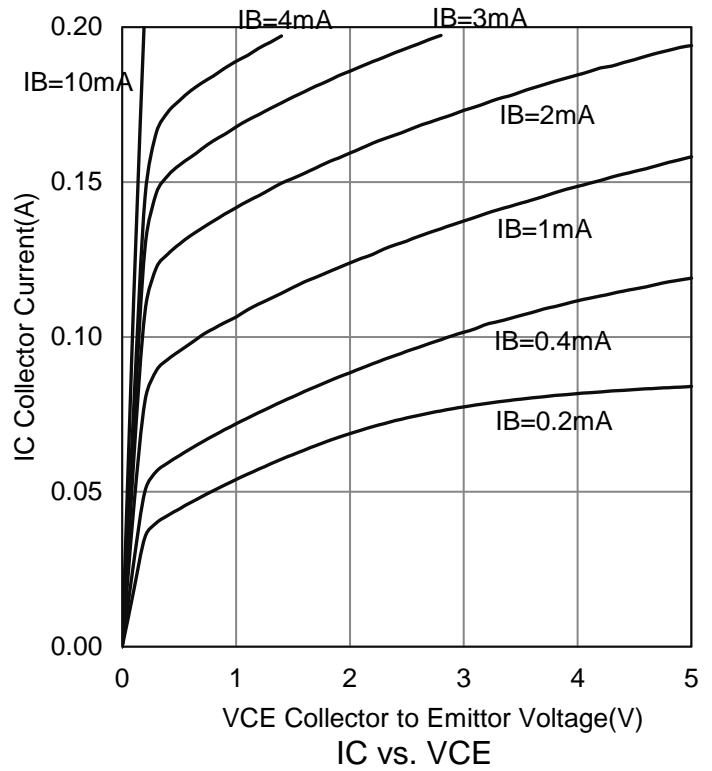
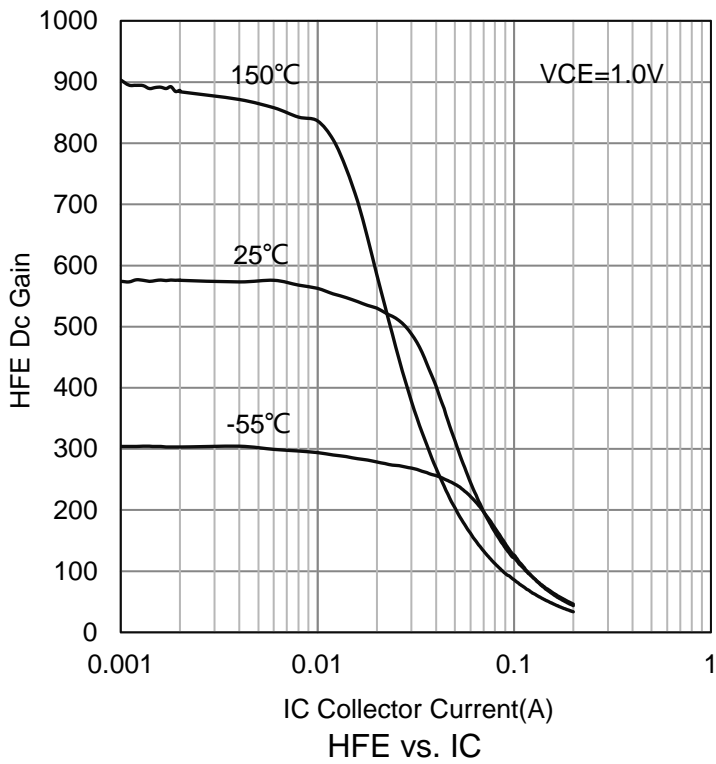

6.ELECTRICAL CHARACTERISTICS CURVES(Con.)

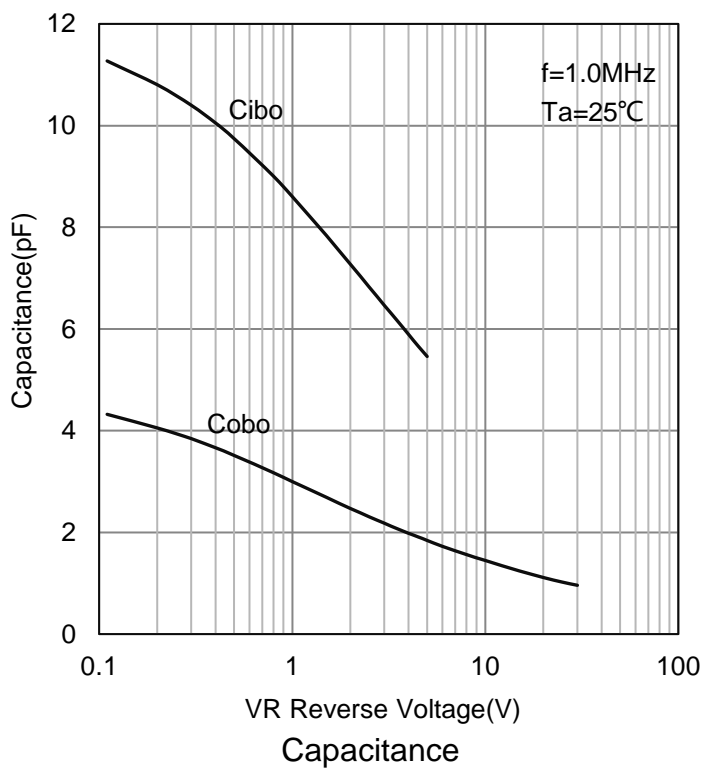
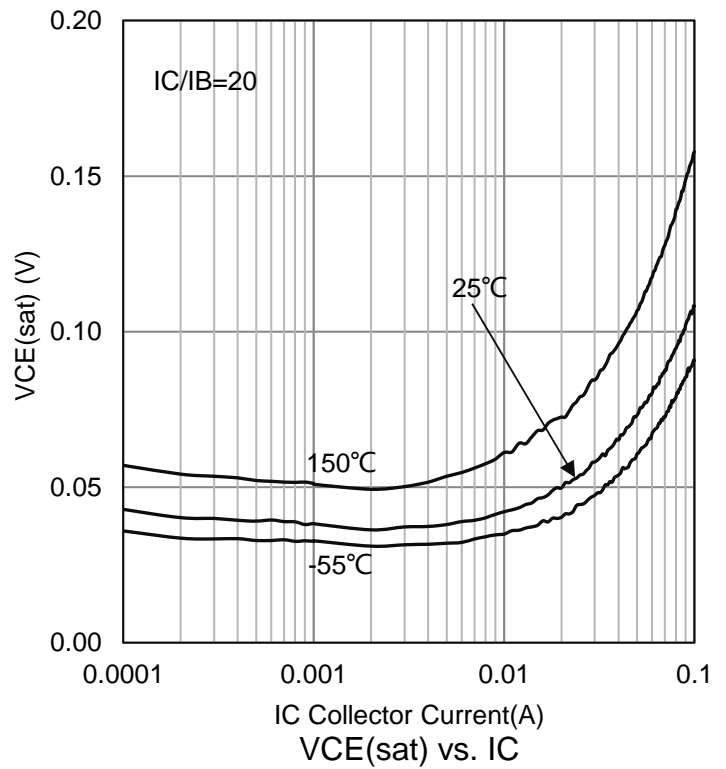
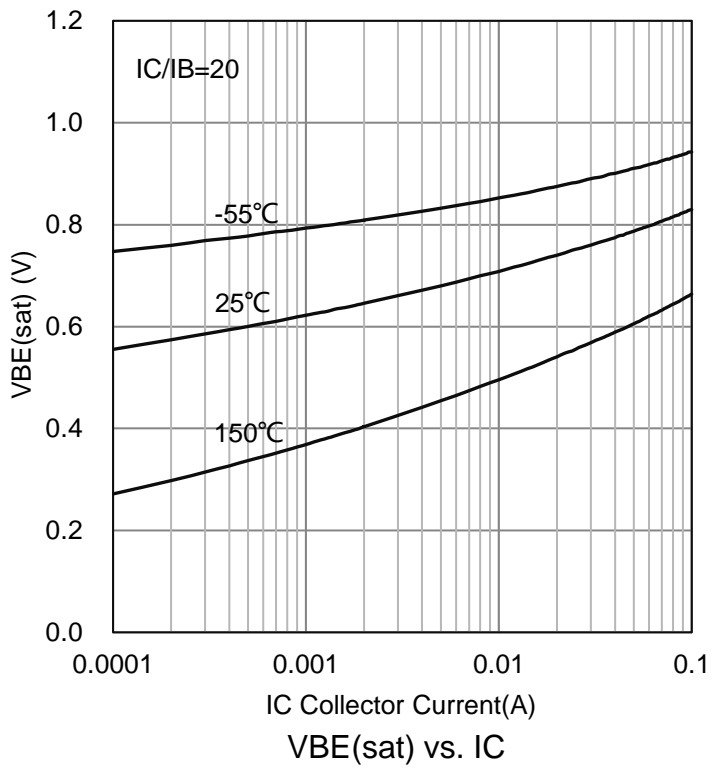

7. OUTLINE AND DIMENSIONS

Notes:

1. DIMENSIONING AND TOLERANCING PER ANSI Y14.5M, 1982.
2. CONTROLLING DIMENSION: MILLIMETERS.
3. MAXIMUM LEAD THICKNESS INCLUDES LEAD FINISH. MINIMUM LEAD THICKNESS IS THE MINIMUM THICKNESS OF BASE MATERIAL.
4. DIMENSIONS D AND E DO NOT INCLUDE MOLD FLASH, PROTRUSIONS OR GATE BURRS.

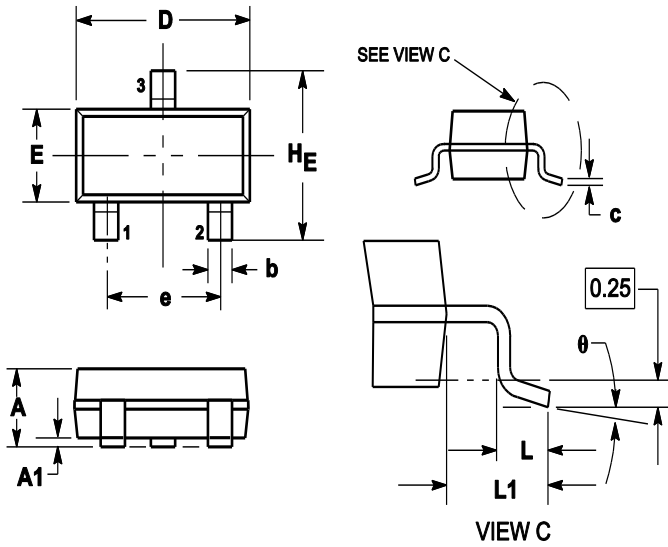

DIM	MILLIMETERS			INCHES		
	MIN	NOM	MAX	MIN	NOM	MAX
A	0.89	1	1.11	0.035	0.04	0.044
A1	0.01	0.06	0.1	0.001	0.002	0.004
b	0.37	0.44	0.5	0.015	0.018	0.02
c	0.09	0.13	0.18	0.003	0.005	0.007
D	2.80	2.9	3.04	0.11	0.114	0.12
E	1.20	1.3	1.4	0.047	0.051	0.055
e	1.78	1.9	2.04	0.07	0.075	0.081
L	0.10	0.2	0.3	0.004	0.008	0.012
L1	0.35	0.54	0.69	0.014	0.021	0.029
HE	2.10	2.4	2.64	0.083	0.094	0.104
θ	0°	---	10°	0°	---	10°

8. SOLDERING FOOTPRINT

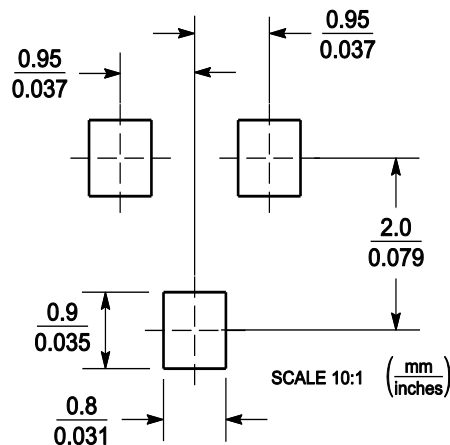

DISCLAIMER

- Before you use our Products, you are requested to carefully read this document and fully understand its contents. LRC shall not be in any way responsible or liable for failure, malfunction or accident arising from the use of any LRC's Products against warning, caution or note contained in this document.
- All information contained in this document is current as of the issuing date and subject to change without any prior notice. Before purchasing or using LRC's Products, please confirm the latest information with a LRC sales representative.

单击下面可查看定价，库存，交付和生命周期等信息

[>>LRC\(乐山无线电\)](#)