

S-SODZ***A-SH Series

Surface Mount Zener Voltage Regulator Diodes

1.0 Watt Steady State

1. FEATURES

- 1.0 Watt SOD123FL zener voltage regulator diodes
- Low profile package for surface mounted applications in order to optimize board spaces
- Plastic package has Underwriters Laboratory Flammability Classification 94V-0
- High temperature soldering guaranteed: 260°C / 10 seconds at terminals
- We declare that the material of product is compliant with RoHS and Halogen free requirements.
- S- prefix for automotive and other applications requiring unique site and control change requirements; AEC-Q101 qualified and PPAP capable.
- MSL: Level 1

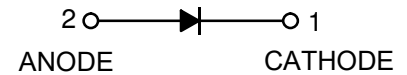
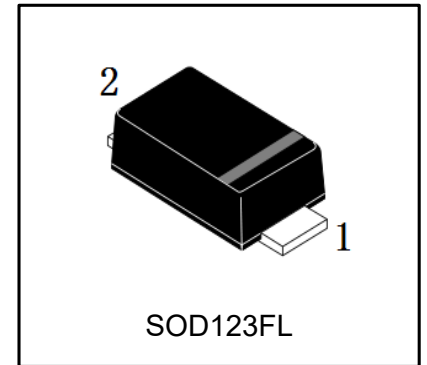

2. MECHANICAL DATA

- Case: JEDEC SOD123FL / MINI SMA molded plastic
- Terminals: Plated terminals, solderable per MIL-STD-750, Method 2026
- Polarity: With color bands that denote cathode end
- Mounting Position: Any
- Weight: Approximately 0.0155 gram
- Quantity: 3000 Units / Tape&Reel

3. MAXIMUM RATINGS (T_A = 25°C unless otherwise specified.)

Single phase, half wave, 60Hz, resistive or inductive load. For capacitive load, derate current by 20%.

PARAMETERS	SYMBOLS	VALUE	UNITS
Steady State Power Dissipation at T _L = 75°C (Note1)	P _{M(AV)}	1.0	Watt
Z-current	I _Z	P _V /V _Z	mA
Operating Junction Temperature Range	T _J	-55 to +150	°C
Storage Temperature Range	T _{STG}	-55 to +150	°C

Notes:

1. 8.0mm² (0.013mm thick) land areas.
2. 8.3ms single half sine-wave, duty cycle= 4 pulses per minutes maximum.

4. ELECTRICAL CHARACTERISTICS (TA = 25°C unless otherwise specified.)

Vz tolerance : ±5%; Tested with pulse tp = 40ms; Vfmax = 1.2V@IF = 200mA; P = 1 W

Part Number	Device Marking Code	Zener Voltage Vz(V)@Izt	Test Current Izt(mA)	Dynamic Impedance		Knee Current Izk(mA)	Max Leakage Current IR(uA)@VR	Reverse Voltage VR(V)	Max Regulator Current IzM (mA)@Ta=50°C
				Zzt(Ω)@Izt	Zzk(Ω)@Izk				
S-SODZ5.1A-SH	Z5.1	5.1	49	7.0	550	1.0	100	1.0	178
S-SODZ5.6A-SH	Z5.6	5.6	45	5.0	600			2.0	164
S-SODZ6.2A-SH	Z6.2	6.2	41	2.0	700			3.0	146
S-SODZ6.8A-SH	Z6.8	6.8	37	4.0	1300			4.0	133
S-SODZ7.5A-SH	Z7.5	7.5	34	4.5	1300			5.0	121
S-SODZ8.2A-SH	Z8.2	8.2	31	5.5	1300			6.0	110
S-SODZ9.1A-SH	Z9.1	9.1	28	6.0	1300			7.0	100
S-SODZ10A-SH	Z10	10	25	7.0	1300	0.25	7.6	91	
S-SODZ11A-SH	Z11	11	23	8.0	1300		5	8.4	83
S-SODZ12A-SH	Z12	12	21	9.0	1300			9.1	76
S-SODZ13A-SH	Z13	13	19	10	1300			9.9	69
S-SODZ15A-SH	Z15	15	17	14	1300			11.4	61
S-SODZ16A-SH	Z16	16	15.5	16	1300			12.2	57
S-SODZ18A-SH	Z18	18	14	20	1300		13.7	50	
S-SODZ20A-SH	Z20	20	12.5	22	1300		15.2	45	
S-SODZ22A-SH	Z22	22	11.5	23	1300		16.7	41	
S-SODZ24A-SH	Z24	24	10.5	25	1300		18.2	38	
S-SODZ27A-SH	Z27	27	9.5	35	1300		20.6	34	
S-SODZ30A-SH	Z30	30	8.5	40	1500		22.8	30	
S-SODZ33A-SH	Z33	33	7.5	45	1500		25.1	27	
S-SODZ36A-SH	Z36	36	7.0	50	1500		27.4	25	
S-SODZ39A-SH	Z39	39	6.5	60	1500		29.7	23	
S-SODZ43A-SH	Z43	43	6.0	70	2500		32.7	22	
S-SODZ47A-SH	Z47	47	5.5	80	2500		35.8	19	
S-SODZ51A-SH	Z51	51	5.0	95	2500		38.8	18	
S-SODZ56A-SH	Z56	56	4.5	110	2500		42.6	16	
S-SODZ62A-SH	Z62	62	4.0	125	2500		47.1	14	
S-SODZ68A-SH	Z68	68	3.7	150	2500		51.7	13	
S-SODZ75A-SH	Z75	75	3.3	175	2500		56	12	
S-SODZ82A-SH	Z82	82	3.0	200	3000		62.2	11	
S-SODZ91A-SH	Z91	91	2.8	250	3000		69.2	10	
S-SODZ100A-SH	Z100	100	2.5	350	3000		76	9	
S-SODZ110A-SH	Z110	110	2.0	550	5000		83	8	
S-SODZ120A-SH	Z120	120	1.5	750	5500		90	7	
S-SODZ130A-SH	Z130	130	1.0	900	6000	98	6		
S-SODZ150A-SH	Z150	150	1.0	1200	6500	113	6		
S-SODZ160A-SH	Z160	160	1.0	1350	7000	120	6		
S-SODZ180A-SH	Z180	180	1.0	1650	8500	135	5		
S-SODZ200A-SH	Z200	200	1.0	1950	10000	150	4		

5. ELECTRICAL CHARACTERISTIC CURVES

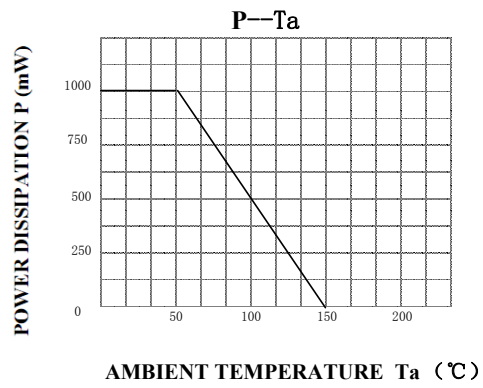
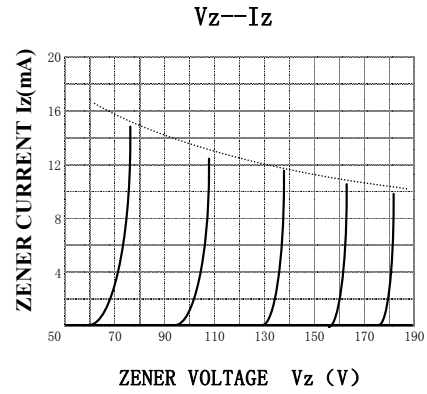
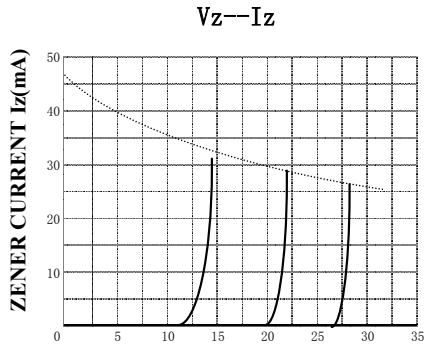

6. PACKAGE DIMENSIONS

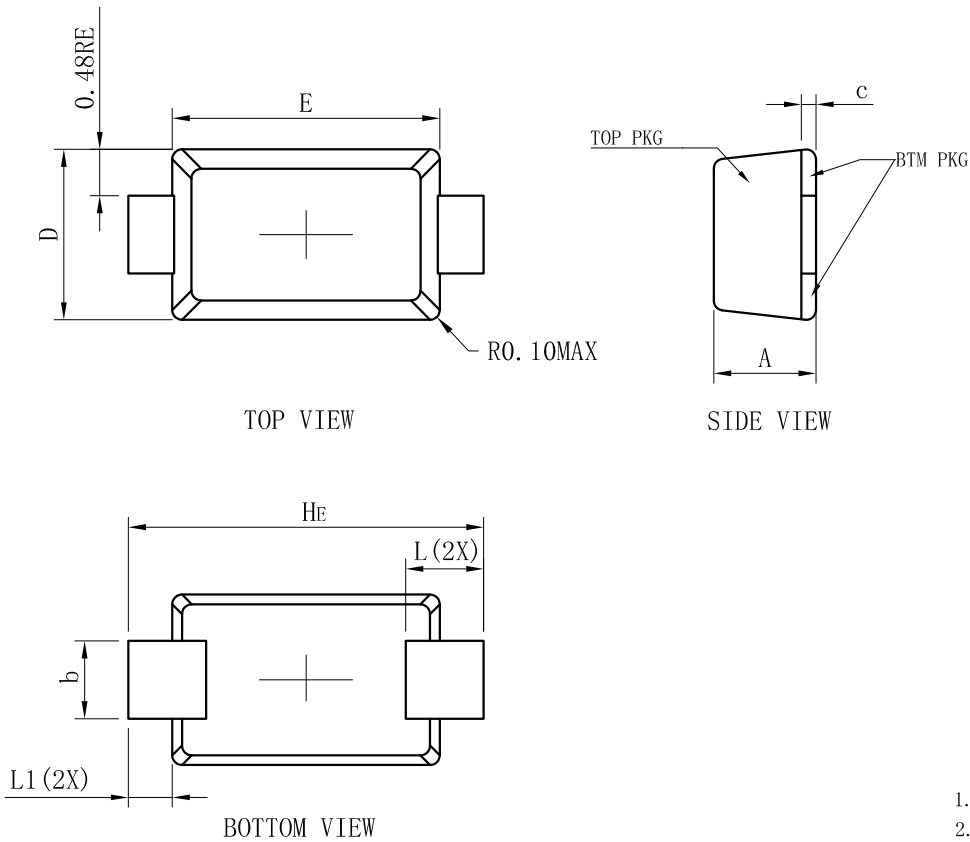

SOD123FL			
DIM	MIN	NOR	MAX
A	0.90	1.05	1.15
b	0.75	0.80	0.95
L	0.50	0.80	1.10
E	2.60	2.75	2.90
D	1.60	1.75	1.90
HE	3.50	3.65	3.80
c	0.12	0.17	0.22
L1	0.25	0.45	0.65
All Dimensions in mm			

GENERAL NOTES

1. Top package surface finish $Ra0.4 \pm 0.2\mu m$
2. Bottom package surface finish $Ra0.7 \pm 0.2\mu m$
3. Side package surface finish $Ra0.4 \pm 0.2\mu m$

7. SOLDERING FOOTPRINT

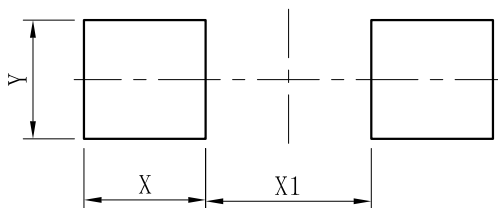

DIM	(mm)
X	1.20
Y	1.10
X1	2.00

8. SUGGESTED THERMAL PROFILE FOR SOLDERING PROCESS

1. Storage environment : Temperature=5~40°C Humidity=55±25%
2. Reflow soldering of surface-mount device

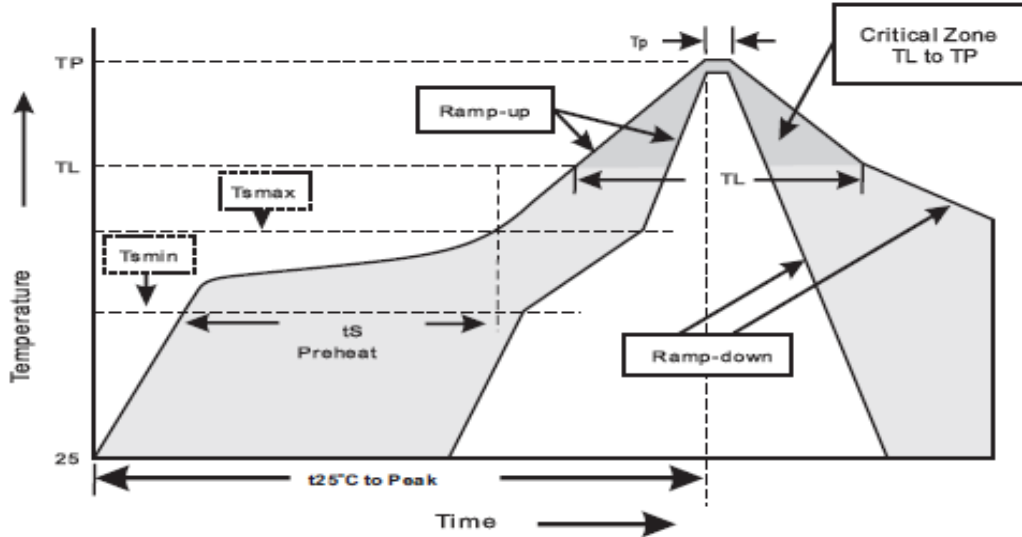

3. Reflow soldering conditions

Profile Feature	Soldering Condition
Average ramp-up rate(T_L to T_P)	<3°C/sec
Preheat	
- Temperature Min(T_{min})	150°C
- Temperature Max(T_{max})	200°C
- Time(min to max)(t_s)	60~120sec
T_{max} to T_L	
- Ramp-up Rate	<3sec
Time maintained above:	
- Temperature (T_L)	217°C
- Time(t_L)	60-260sec
Peak Temperature(T_P)	255 -0/+5°C
Time within 5°C of actual Peak Temperature(T_P)	10~30sec
Ramp-down Rate	<6°C/sec
Time 25°C to Peak Temperature	<6minutes

9. HIGH RELIABILITY TEST CAPABILITIES

Item Test	Condition	Reference
Solder Resistance	at 260±5°C for 10±2sec immerse body into solder 1/16" ± 1/32"	MIL-STD-750D METHOD-2031
Solderability	at 245±5°C for 5 sec	MIL-STD-202F METHOD-208
High Temperature Reverse Bias	V _R =80% rate at T _j =150°C for 168hrs	MIL-STD-750D METHOD-1038
Forward Operation Life	Rated average rectifier current T _A =25°C for 500hrs	MIL-STD-750D METHOD-1027
Intermittent Operation Life	T _A =25°C , I _F =I _O On state:power on for 5 min. Off state:power off for 5 min. on and off for 500 cycles	MIL-STD-750D METHOD-1036
Pressure Cooker	15P _{SIG} at T _A =121°C for 4hrs	JESD22-A102
Temperature Cycling	-55°C to +125°C dwelled for 30 min. and transferred for 5min. Total 10 cycles	MIL-STD-750D METHOD-1051
Thermal Shock	0°C for 5min. Rise to 100°C for 5min. Total 10 cycles	MIL-STD-750D METHOD-1056
Forward Surge	8.3ms single half sine-wave superimposed on rated load,one surge	MIL-STD-750D METHOD-4066-2
Humidity	at T _A =85°C , RH=85% for 1000hrs	MIL-STD-750D METHOD-1021
High Temperature Storage Life	at 175°C for 1000hrs	MIL-STD-750D METHOD-1031

DISCLAIMER

- Curve guarantee in the specification. The curve of test items with electric parameter is used as quality guarantee. The curve of test items without electric parameter is used as reference only.
- Before you use our Products for new Project, you are requested to carefully read this document and fully understand its contents. LRC shall not be in any way responsible or liable for failure, malfunction or accident arising from the use of any LRC's Products against warning, caution or note contained in this document.
- All information contained in this document is current as of the issuing date and subject to change without any prior notice. Before purchasing or using LRC's Products, please confirm the latest information with a LRC sales representative.



Proprietary Information

Title: Power Packages Product Packing Specification

功率产品包装规范

Document Number: APS-QA-QS-009

Revision C

Page 3 of 6



8.1.2 Label position and QA stamp position.(Empty area) 标签张贴位置及QA印章位置。(印章盖 标签空白区)



7英寸卷盘标签张贴及QA印章位置



13英寸卷盘标签张贴及QA印章位置

8.1.3 Ensure direction In the same reel. The same steel coil plate direction, With antistatic bubble to package reel. Refer to the below picture.

同一箱内的卷盘方向一致,用防静电泡沫对卷盘进行包裹。



7英寸卷盘防静电泡沫包裹



13英寸卷盘防静电泡沫包裹

Do not copy without written permission from Advanced Power Semiconductor



Proprietary Information

Title: Power Packages Product Packing Specification

功率产品包装规范

Document Number: APS-QA-QS-009

Revision C

Page 4 of 6

8.1.4 Put in the antistatic packing box after packaged reels. And QA stamp on the box label .

将包装好的卷盘放入防静电纸箱中，并 盒标签上盖章。



7 英寸卷盘内盒及标签



13 英寸卷盘内盒及标签

8.1.5 Product use printing inner box. 产品使用LRC印字内箱。



7英寸卷盘内箱印字（侧面）



13英寸卷盘内箱印字（正面）

8.1.6 Inner box packing quantity requirement. 内盒包装数量要求。

Product Description	QTY
SOD123-FL	1-10Reels
SOD323-HE	1-10Reels
SMA-FL	1-7Reels
SMB-FL	1-4Reels

8.1.7 With transparent tape sealing. 透明胶带封箱。

Do not copy without written permission from Advanced Power Semiconductor



Proprietary Information

Title: Power Packages Product Packing Specification 功率产品包装规范

Document Number: APS-QA-QS-009

Revision C

Page 5 of 6



7英寸内箱封盒



13英寸内箱封盒

8.1.8 Outer box size and packing quantity requirement, 外箱尺寸及包装数量要求。

Product Description	卷盘尺寸	Height (H)	Width (W)	Length (L)	Max. Qty
Power Device	7 英寸	410mm	400mm	445mm	12
Power Device	13 英寸	410mm	400mm	445mm	5



7 英寸卷盘产品装箱



13 英寸卷盘产品装箱

统一方向

Do not copy without written permission from Advanced Power Semiconductor



Proprietary Information

Title: Power Packages Marking & Taping Specification

功率封装字模和编带规范

Document Number: APS-QA-QS-010

Revision C

Page 6 of 9

8.2 Standard Products Taping Specification

标准产品编带规范

8.2.1 Tape length of no component

空带长度说明

Taping leader length 引导部分: $440\text{mm} \pm 40\text{mm}$, Tape trailer 尾部: $200\text{mm} \pm 40\text{mm}$

Figure 4

Tape Ends For Finished Goods Reel

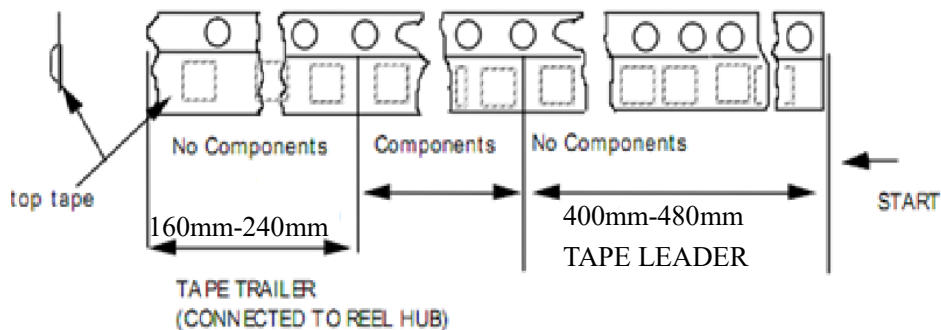

8.2.2 Component packaging orientation: The cathode lead is close to the carrier tape's index hole.

产品放置方向: 印阴极带引脚邻近载带索引孔



Do not copy without written permission from Advanced Power Semiconductor



Proprietary Information

Title: Power Packages Marking & Taping Specification

功率封装字模和编带规范

Document Number: APS-QA-QS-010

Revision C

Page 7 of 9

8.2.3 Tape enwind orientation

编带缠绕方向要求

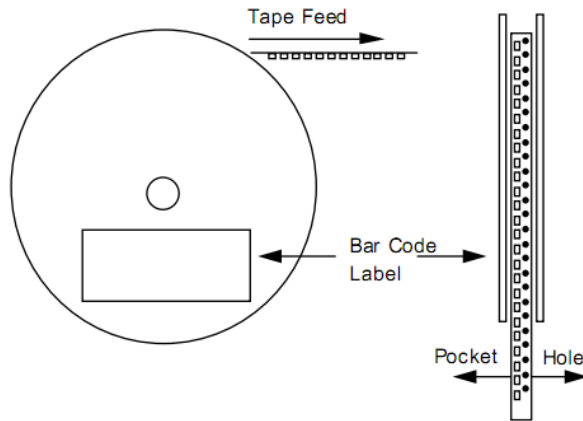

Do not copy without written permission from Advanced Power Semiconductor

单击下面可查看定价，库存，交付和生命周期等信息

[>>LRC\(乐山无线电\)](#)