

LINEAR INTEGRATED CIRCUIT

LR431

PROGRAMMABLE PRECISION REFERENCE

DESCRIPTION

The LRC LR431 is a three-terminal adjustable regulator with a guaranteed thermal stability over applicable temperature ranges. The output voltage may be set to any value between V_{ref} (approximately 2.5V) and 36V with two external resistors. It provides very wide applications, including shunt regulator, series regulator, switching regulator, voltage reference and others.

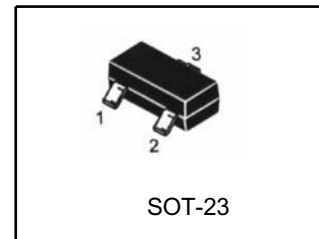

SOT-23 1: Ref; 2: Cathode; 3: Anode

FEATURES

- Programmable output Voltage to 36V.
- Low dynamic output impedance 0.2Ω
- Sink current capability of 1 to 100mA.
- Equivalent full-range temperature coefficient of 50ppm/ $^{\circ}C$ typical for operation over full rated operating temperature range.

Pb-Free package is available

BLOCK DIAGRAM

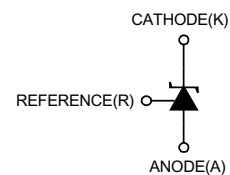
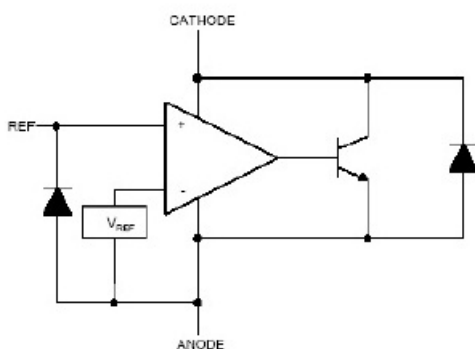

LR431 LINEAR INTEGRATED CIRCUIT

ABSOLUTE MAXIMUM RATINGS (Operating temperature range applies unless otherwise specified)

PARAMETER	SYMBOL	VALUE	UNIT
Cathode Voltage	V _{KA}	36	V
Cathode Current Range(Continuous)	I _{KA}	-100 ~ +150	mA
Reference Input Current Range	I _{ref}	-0.05 ~ +10	mA
Operating Junction Temperature	T _j	150	°C
Operating Ambient Temperature	T _{opr}	0 ~ +70 / -40 ~ +125	°C
Storage Temperature	T _{stg}	-65 ~ +150	°C

RECOMMENDED OPERATING CONDITIONS

PARAMETER	SYMBOL	MIN	TYP	MAX	UNIT
Cathode Voltage	V _{KA}	V _{REF}		36	V
Cathode Current	I _{KA}	1		100	mA

ELECTRICAL CHARACTERISTICS (T_a=25°C, unless otherwise specified)

PARAMETER	SYMBOL	TEST CONDITIONS	MIN	TYP	MAX	UNIT
Reference Input Voltage *	V _{ref}	V _{KA} =V _{REF} , I _{KA} =10mA		2.50 2.495		V
Deviation of reference Input Voltage Over temperature(note 1)	ΔV _{ref} /ΔT	V _{KA} =V _{REF} , I _{KA} =10mA T _{MIN} ≤T _A ≤T _{MAX}		4.5	17	mV
Ratio of Change in Reference Input Voltage to the Change in Cathode Voltage	ΔV _{ref} / ΔV _{KA}	I _{KA} =10mA ΔV _{KA} =10V~V _{REF} ΔV _{KA} =36V~10V		-1.0 -0.5	-2.7 -2.0	mV/V
Reference Input Current	I _{ref}	I _{KA} =10mA, R ₁ =10kΩ, R ₂ =∞		1.5	4	μA
Deviation of Reference Input Current Over Full Temperature Range	ΔI _{ref} /ΔT	I _{KA} =10mA, R ₁ =10kΩ, R ₂ =∞ T _A =full Temperature		0.4	1.2	μA
Minimum Cathode Current for Regulation	I _{KA} (min)	V _{KA} =V _{REF}		0.45	1.0	mA
Off-State Cathode Current	I _{KA} (OFF)	V _{KA} =36V, V _{REF} =0		0.05	1.0	μA
Dynamic Impedance	Z _{KA}	V _{KA} =V _{REF} , I _{KA} =1 to 100mA f≤1.0kHz		0.15	0.5	Ω

* CLASSIFICATION OF V_{ref} AND PACKAGE

Type	RanK	Range(V)	Marking	Packa	T _{opr}
LR431ALT1G	0.5%	2.487~2.512	RA	SOT-23	0~+70 °C
LR431BLT1G	1%	2.475~2.525	RB	SOT-23	0~+70 °C
LR431APLT1G	0.5%	2.482~2.507	RA1	SOT-23	0~+70 °C
LR431BPLT1G	1%	2.470~2.520	RB1	SOT-23	0~+70 °C
LR431ATLT1G	0.5%	2.487~2.512	RA2	SOT-23	-40~+125 °C
LR431BTLT1G	1%	2.475~2.525	RB2	SOT-23	-40~+125 °C
LR431APTTLT1G	0.5%	2.482~2.507	RA3	SOT-23	-40~+125 °C
LR431BP TTLT1G	1%	2.470~2.520	RB3	SOT-23	-40~+125 °C

LR431 LINEAR INTEGRATED CIRCUIT

TYPICAL PERFORMANCE CHARACTERISTICS

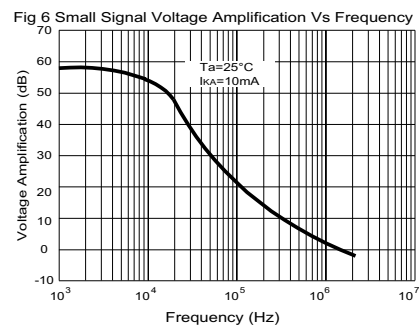
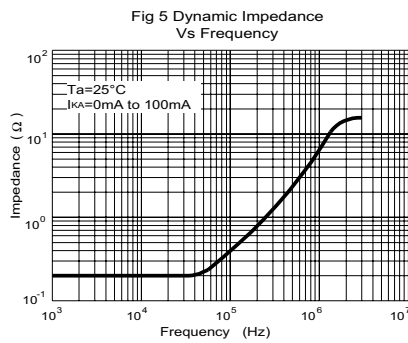
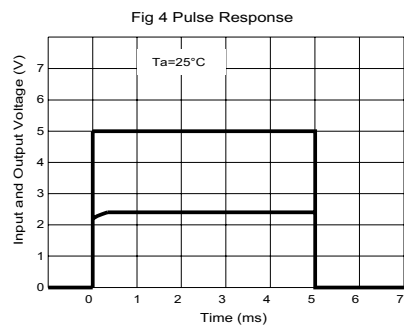
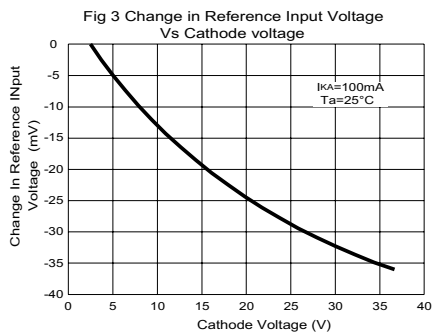
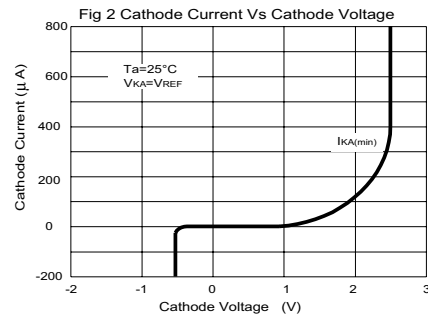
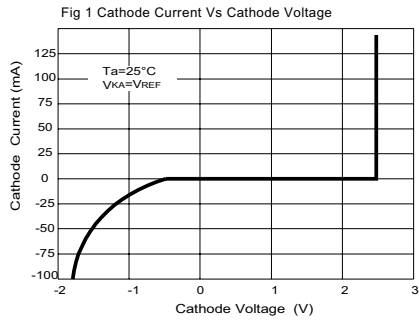

LR431 LINEAR INTEGRATED CIRCUIT

TEST CIRCUIT

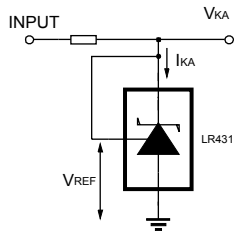

Fig 7 Test Circuit For $V_{KA}=V_{REF}$

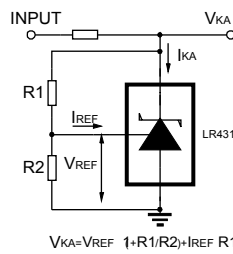

Fig 8 Test Circuit for $V_{KA} \geq V_{REF}$

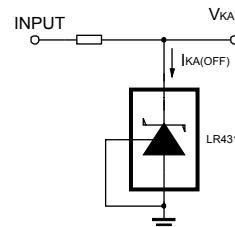

Fig 9 Test Circuit For $I_{KA(OFF)}$

APPLICATION CIRCUIT

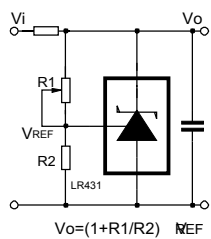

Fig 10 Shutdown Regulator

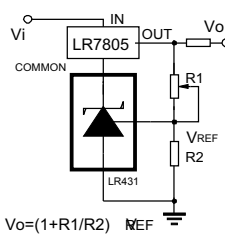

Fig 11 Output Control of a Three-Terminal Fixed Regulator

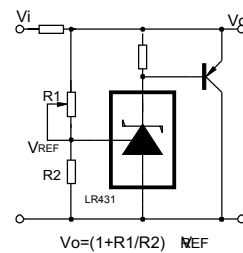

Fig 12 Higher-current Shunt Regulator

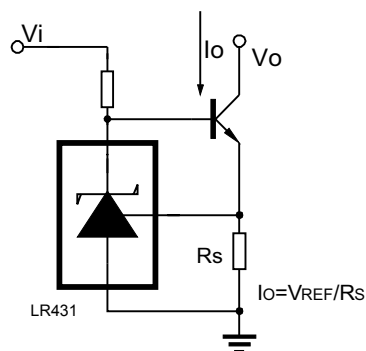

Fig 13 Constant-current Sink

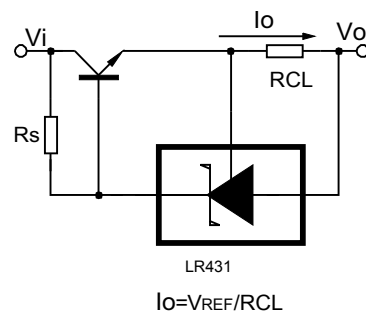
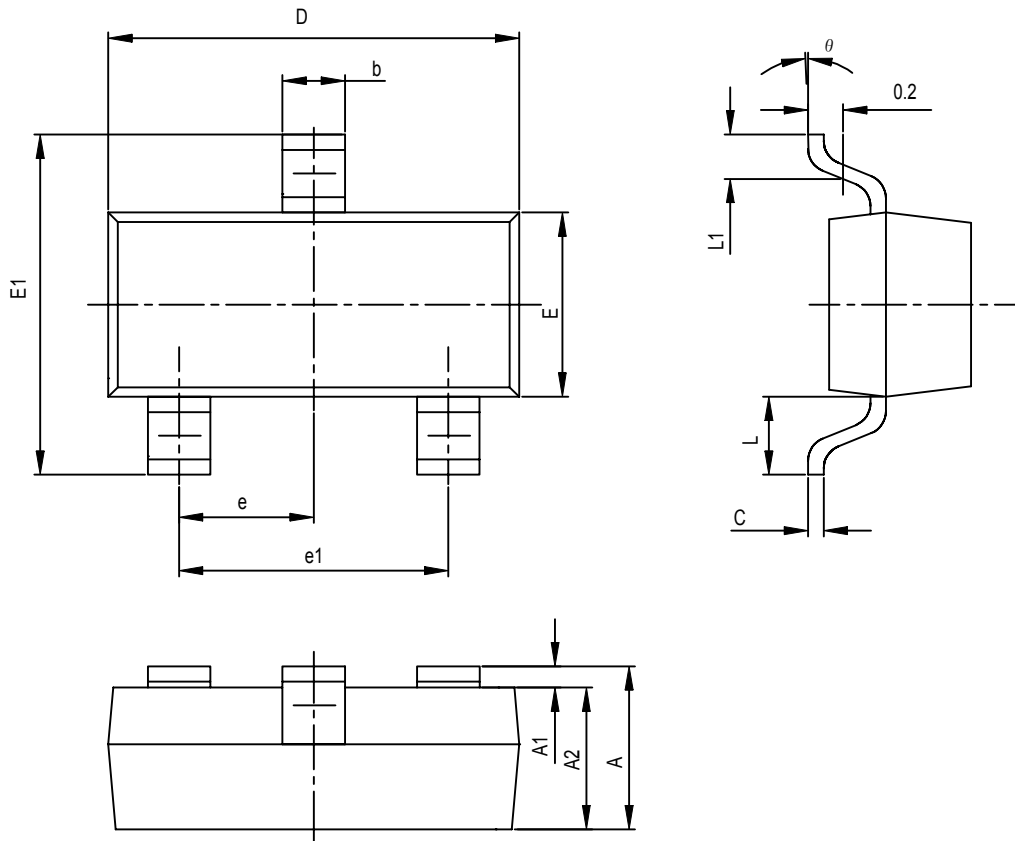

Fig 14 Current Limiting or Current Source

SOT-23 PACKAGE OUTLINE DIMENSIONS

Symbol	Dimensions In Millimeters		Dimensions In Inches	
	Min	Max	Min	Max
A	0.900	1.100	0.035	0.043
A1	0.000	0.100	0.000	0.004
A2	0.900	1.000	0.035	0.039
b	0.300	0.500	0.012	0.020
c	0.080	0.150	0.003	0.006
D	2.800	3.100	0.110	0.118
E	1.200	1.610	0.047	0.055
E1	2.250	2.550	0.089	0.100
e	0.950TPY		0.037TPY	
e1	1.800	2.000	0.071	0.079
L	0.550REF		0.022REF	
L1	0.300	0.500	0.012	0.020
θ	0°	8°	0°	8°

单击下面可查看定价，库存，交付和生命周期等信息

[>>LRC\(乐山无线电\)](#)