

LMBT493NELT1G

S-LMBT493NELT1G

General Purpose Transistors NPN Silicon

1. FEATURES

- We declare that the material of product compliance with RoHS requirements and Halogen Free.
- S- prefix for automotive and other applications requiring unique site and control change requirements; AEC-Q101 qualified and PPAP capable.

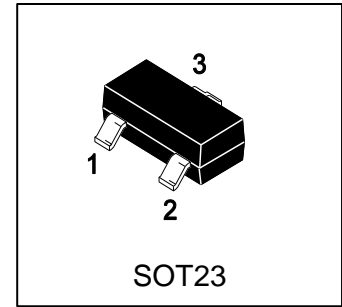

2. DEVICE MARKING AND ORDERING INFORMATION

Device	Marking	Shipping
LMBT493NELT1G	NE	3000/Tape&Reel
LMBT493NELT3G	NE	10000/Tape&Reel

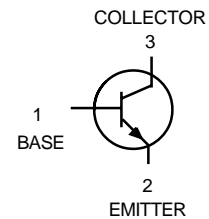

3. MAXIMUM RATINGS(Ta = 25°C)

Parameter	Symbol	Limits	Unit
Collector-Emitter Voltage	V _{CEO}	100	V
Collector-Base voltage	V _{CBO}	120	V
Emitter-Base Voltage	V _{EB0}	5	V
Collector current	I _C	1000	mA
Junction and Storage temperature	T _J , T _{stg}	-55~+150	°C

4. THERMAL CHARACTERISTICS

Parameter	Symbol	Limits	Unit
Total Device Dissipation(Note 1)	PD	417	mW
Thermal Resistance, Junction-to-Ambient	R _{θJA}	300	°C/W
Thermal Resistance, Junction-to-Case	R _{θJC}	108	°C/W

1.30.0mm×25.0mm×1.6mm(FR4), Copper foil thickness 35μm;

5. ELECTRICAL CHARACTERISTICS (Ta= 25°C)

Characteristic	Symbol	Min.	Typ.	Max.	Unit
Collector-Base Breakdown voltage (IC = 100μA)	V(BR)CBO	120	-	-	V
Collector-Emitter Breakdown Voltage (IC =10mA)	V(BR)CEO	100	-	-	V
Emitter-Base Breakdown Voltage (IE =100μA)	V(BR)EBO	5	-	-	V
Collector Cutoff Current (VCB =100 V)	ICBO	-	-	100	nA
Collector cut-off current (VCES =100V, IE =0)	ICES	-	-	100	nA
Emitter cut-off current (VEB =4V, IC =0)	IEBO	-	-	100	nA
DC Current Gain (VCE =10V, IC =1mA) (VCE =10V, IC =250mA) (VCE =10V, IC =0.5A) (VCE =10V, IC =1A)	HFE	80 100 60 20		300	
Collector-Emitter Saturation Voltage (IC =500mA, IB =50mA) (IC =1A, IB =100mA)	VCE(S)	- -	- -	0.3 0.6	V
Base-emitter saturation voltage (IC =1A, IB =100mA)	VBE(sat)	-	-	1.2	V
Base-emitter voltage (VCE =10V, IC =1A)	VBE	-	-	1	V
Transition frequency (VCE =10V, IC =50mA, f=100MHz)	fT	100	-	-	MHz
Collector output capacitance (VCB =10V, IE =0, f=1MHz)	Cob	-	-	10	pF

2.Pulse Test: Pulse Width ≤300 μs, Duty Cycle ≤2.0%.

6.ELECTRICAL CHARACTERISTICS CURVES

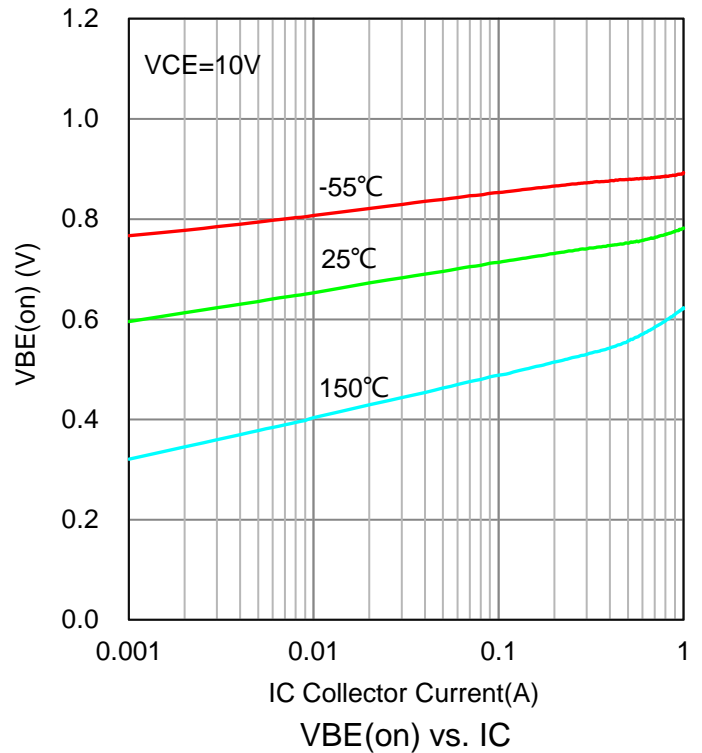
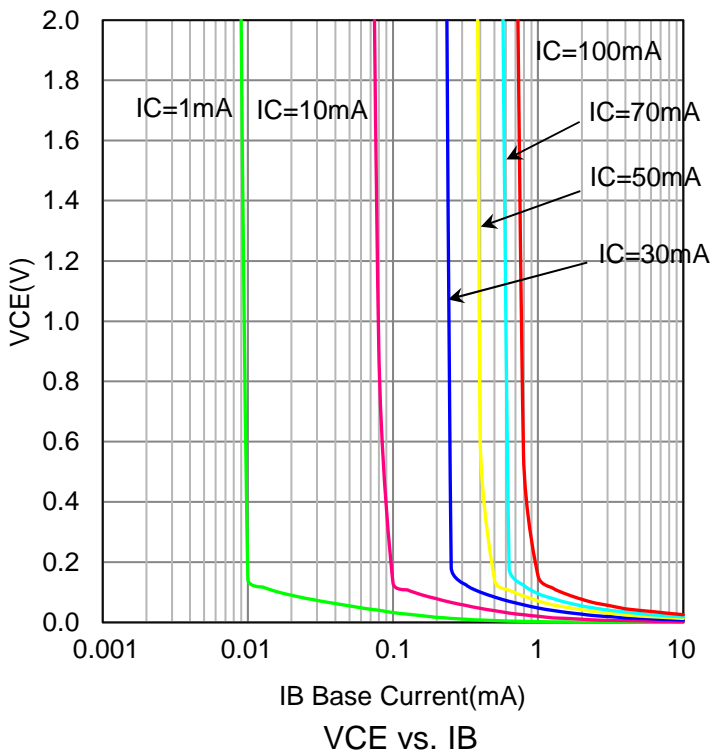
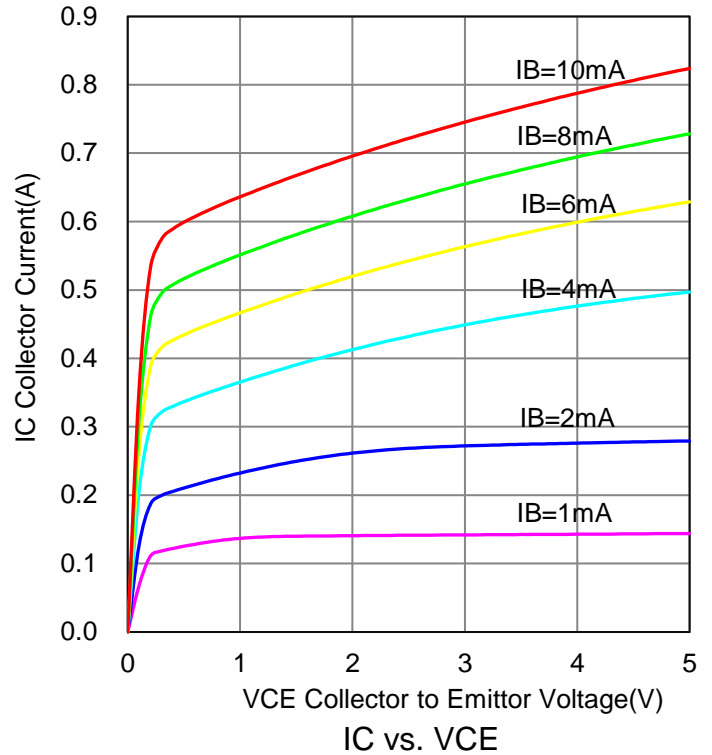
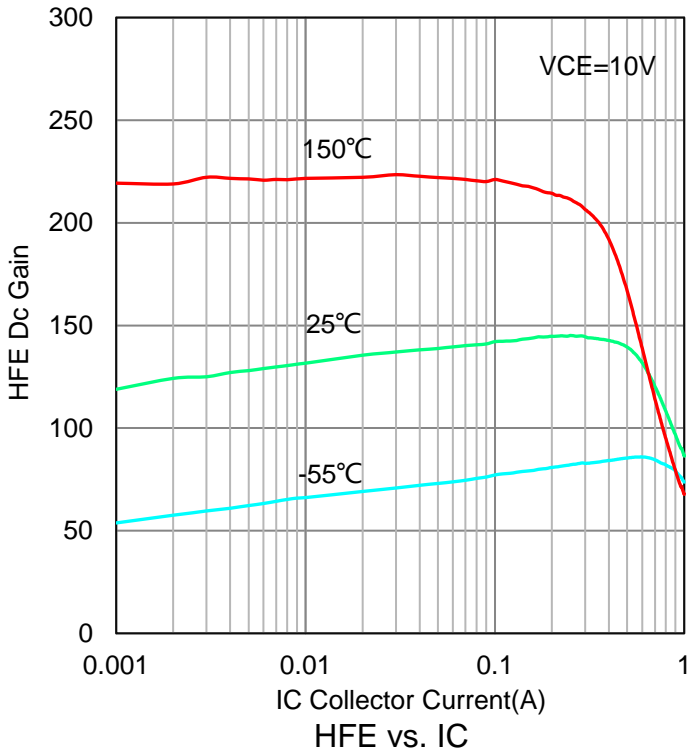

6.ELECTRICAL CHARACTERISTICS CURVES(Con.)

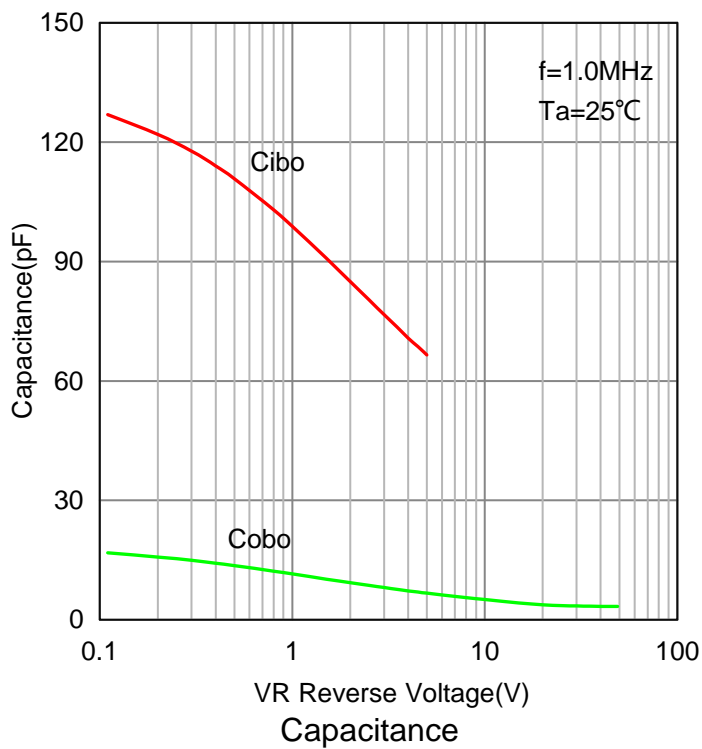
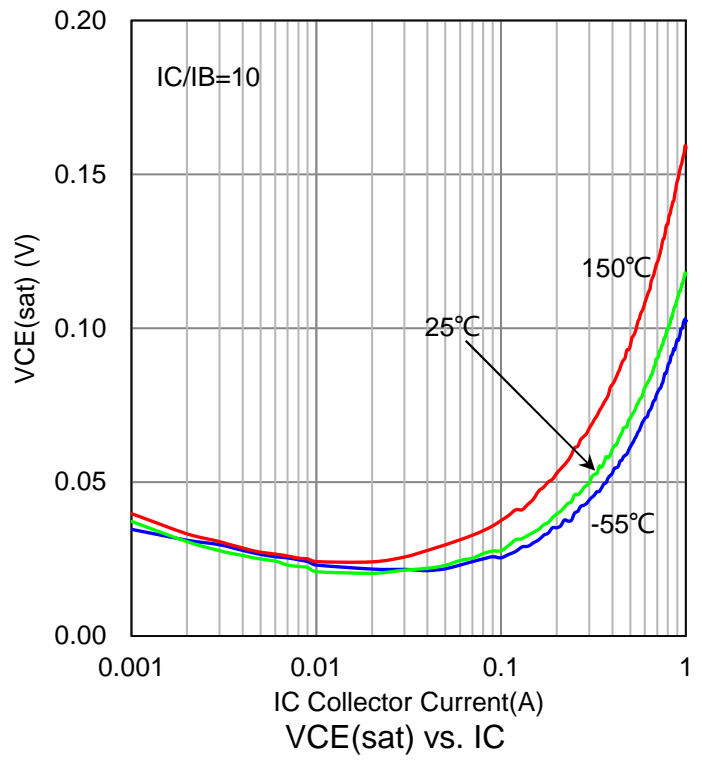
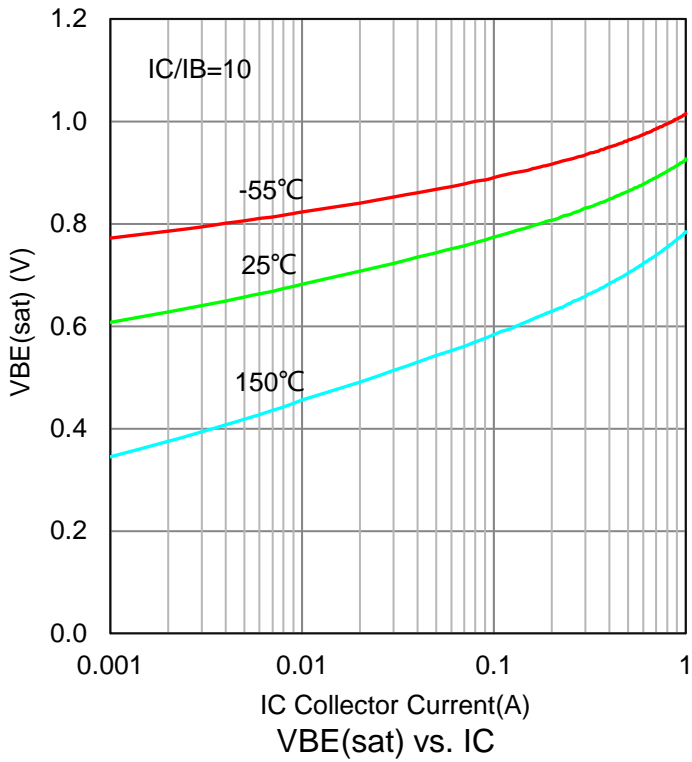

7.OUTLINE AND DIMENSIONS

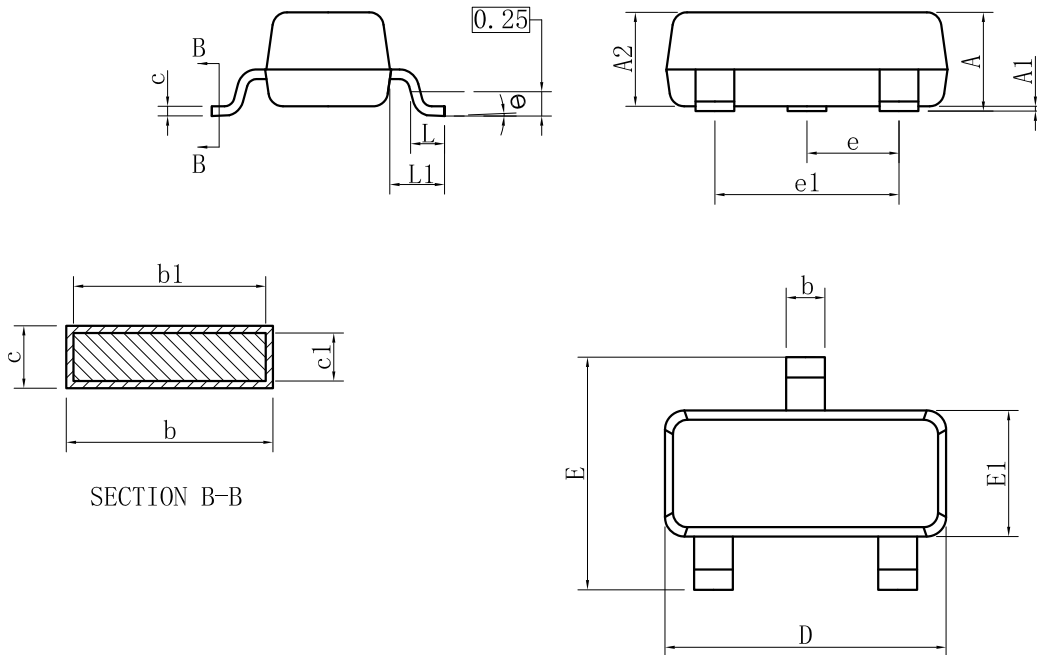

SOT23			
DIM	MIN	NOR	MAX
A	0.89	-	1.12
A1	0.01	-	0.10
A2	0.88	0.95	1.02
b	0.30	-	0.50
b1	0.30	0.40	0.45
c	0.08	-	0.20
c1	0.08	0.10	0.16
D	2.80	2.90	3.04
E	2.10	-	2.64
E1	1.20	1.30	1.40
e	0.95BSC		
e1	1.90BSC		
L	0.40	0.46	0.60
L1	0.54REF		
θ	0°	-	8°
All Dimensions in mm			

GENERAL NOTES

1. Top package surface finish $Ra0.4 \pm 0.2\mu m$
2. Bottom package surface finish $Ra0.7 \pm 0.2\mu m$
3. Side package surface finish $Ra0.4 \pm 0.2\mu m$

8.SOLDERING FOOTPRINT

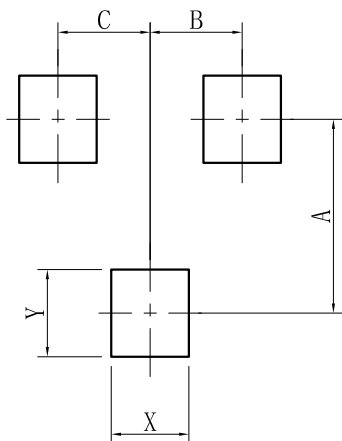

SOT-23	
DIM	(mm)
X	0.80
Y	0.90
A	2.00
B	0.95
C	0.95

DISCLAIMER

- Curve guarantee in the specification. The curve of test items with electric parameter is used as quality guarantee. The curve of test items without electric parameter is used as reference only.
- Before you use our Products for new Project, you are requested to carefully read this document and fully understand its contents. LRC shall not be in any way responsible or liable for failure, malfunction or accident arising from the use of any LRC's Products against warning, caution or note contained in this document.
- All information contained in this document is current as of the issuing date and subject to change without any prior notice. Before purchasing or using LRC's Products, please confirm the latest information with a LRC sales representative.

单击下面可查看定价，库存，交付和生命周期等信息

[>>LRC\(乐山无线电\)](#)