

# LSI1012XT1G

## S-LSI1012XT1G

N-Channel 1.8-V (G-S) MOSFET

### 1. FEATURES

- Gate-Source ESD Protected
- High-Side Switching
- Low On-Resistance: 0.7Ω
- Low Threshold: 0.8 V (typ)
- Fast Switching Speed: 10 ns
- We declare that the material of product compliance with RoHS requirements and Halogen Free.
- S- prefix for automotive and other applications requiring unique site and control change requirements; AEC-Q101 qualified and PPAP capable.

### 2. APPLICATION

- Drivers: Relays, Solenoids, Lamps, Hammers, Displays, Memories
- Battery Operated Systems
- Power Supply Converter Circuits
- Load/Power Switching Cell Phones, Pagers

### 3. DEVICE MARKING AND RESISTOR VALUES

Device	Marking	Shipping
LSI1012XT1G	A	3000/Tape&Reel
LSI1012XT3G	A	10000/Tape&Reel

### 4. MAXIMUM RATINGS(Ta = 25°C)

Parameter	Symbol	5 secs	Steady State	Unit
Drain-Source Voltage	VDS	20		V
Gate-Source Voltage	VGS	±6		V
Continuous Drain Current (TJ = 150°C) (Note 2)	ID	TA = 25°C	500	mA
		TA = 85°C	350	
Pulsed Drain Current(Note 1)	IDM	1000		
Continuous Source Current (diode conduction)(Note 2)	IS	275	250	
Maximum Power Dissipation(Note 2)	PD	TA = 25°C	250	mW
		TA = 85°C	140	
Operating Junction and Storage Temperature Range	TJ , Tstg	-55 ~+150		°C

1.Pulse test; pulse width ≤ 300 μs, duty cycle ≤ 2%.

2.Guaranteed by design, not subject to production testing.

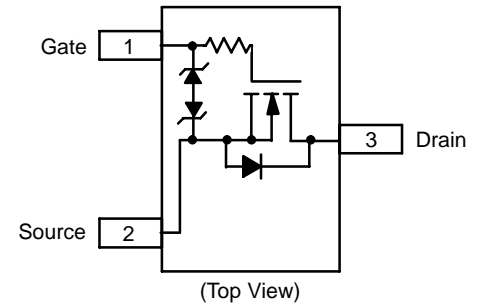
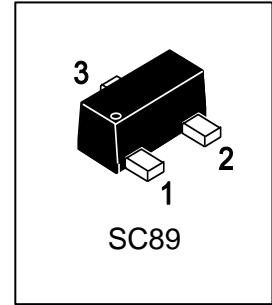

### MARKING DIAGRAM

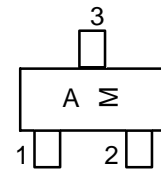

A = Specific Device Code  
M = Month Code

**5. ELECTRICAL CHARACTERISTICS (Ta= 25°C)**

Static

Characteristic	Symbol	Min.	Typ.	Max.	Unit
Gate Threshold Voltage (VDS = VGS , ID = 250μA )	VGS(th)	0.45	-	0.9	V
Gate-Body Leakage (VDS = 0 V, VGS = ±4.5 V)	IGSS	-	±0.5	±1	μA
Zero Gate Voltage Drain Current (VDS = 20 V, VGS = 0 V ) (VDS = 20 V, VGS = 0 V, TJ = 85°C)	IDSS	-	0.3	100	nA μA
On-State Drain Current(Note 1) (VDS = 5 V, VGS = 4.5 V)	ID(on)	700	-	-	mA
Drain-Source On-State Resistance(Note 1) (VGS = 4.5 V, ID = 600 mA) (VGS = 2.5 V, ID = 500 mA) (VGS = 1.8 V, ID = 350 mA)	RDS(on)		0.41 0.53 0.7	0.7 0.85 1.25	Ω
Forward Transconductance(Note 1) (VDS = 10 V, ID = 400 mA)	gfs		1		S
Diode Forward Voltage(Note 1) (IS = 150 mA, VGS = 0 V)	VSD		0.8	1.2	V

Dynamic(Note 2)

Total Gate Charge	(VDS = 10 V, VGS = 4.5 V, ID = 250 mA)	Qg		750		pC
Gate-Source Charge		Qgs		75		
Gate-Drain Charge		Qgd		225		
Turn-On Delay Time	(VDD = 10 V, RL = 47Ω, ID=200 mA, VGEN = 4.5 V, RG = 10Ω)	td(on)		5		ns
Rise Time		tr		5		
Turn-Off Delay Time		td(off)		25		
Fall Time		tf		11		

**6.ELECTRICAL CHARACTERISTICS CURVES**

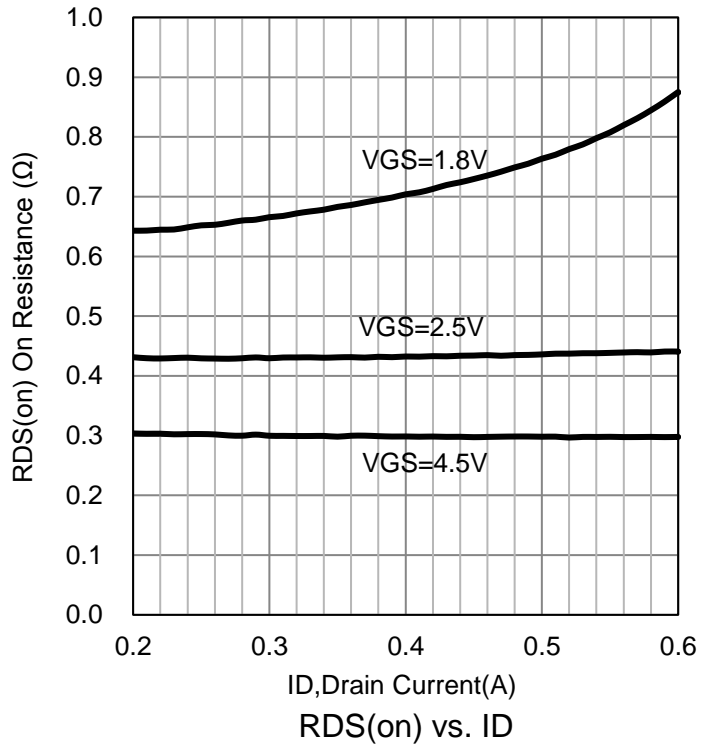
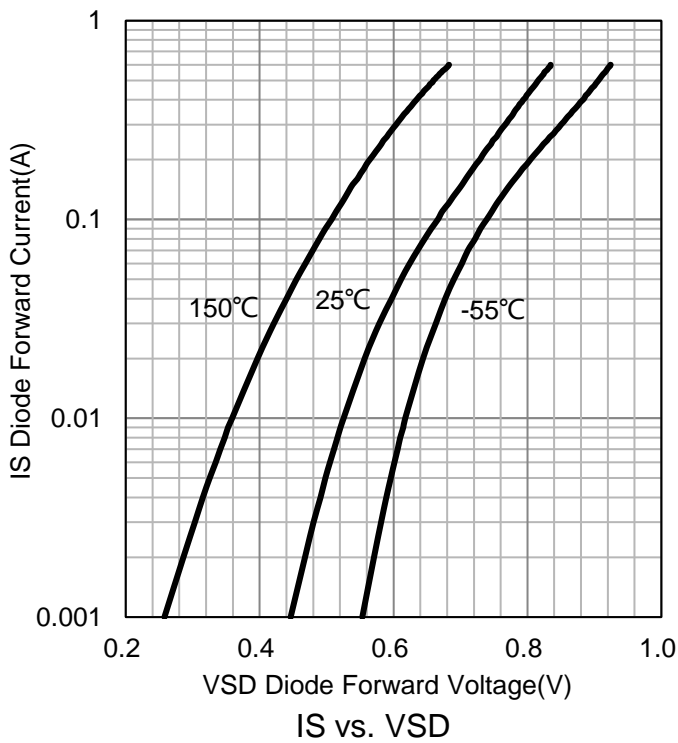
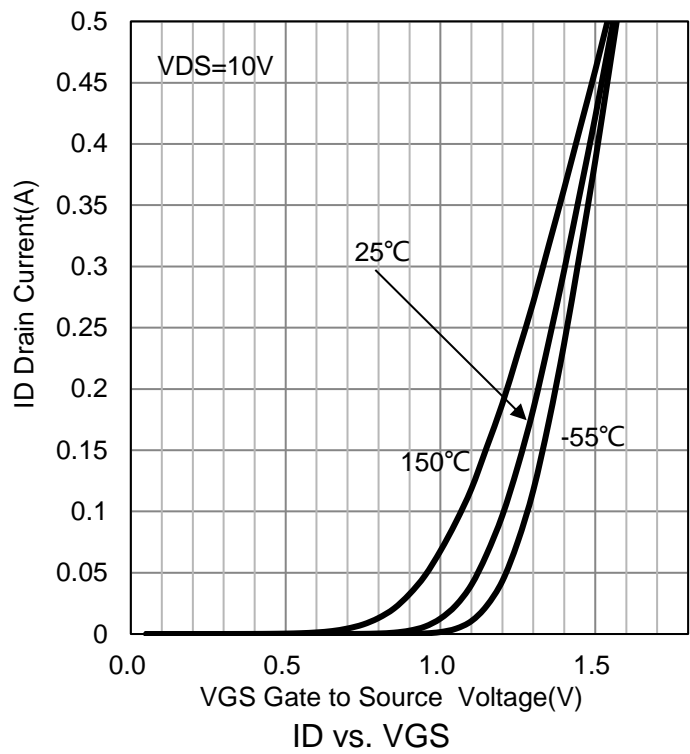
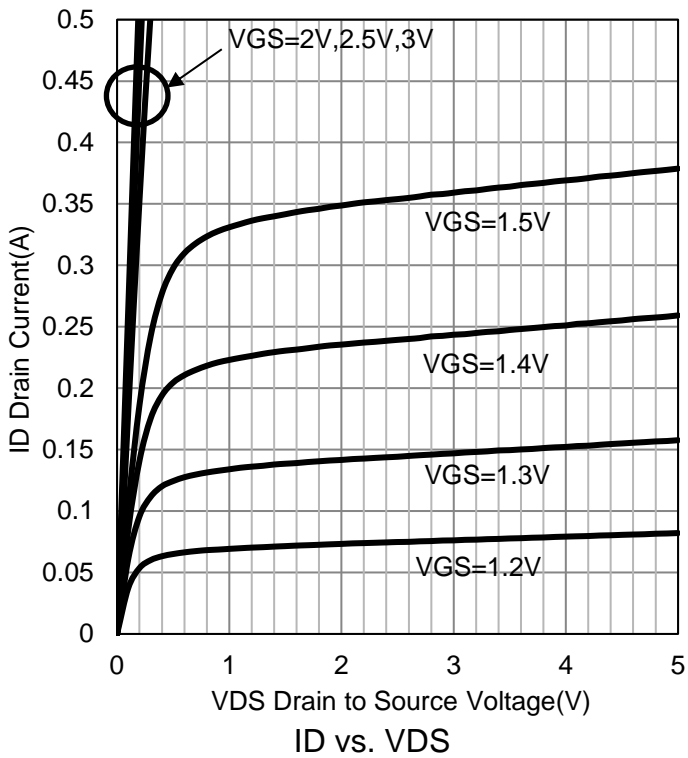

6.ELECTRICAL CHARACTERISTICS CURVES(Con.)

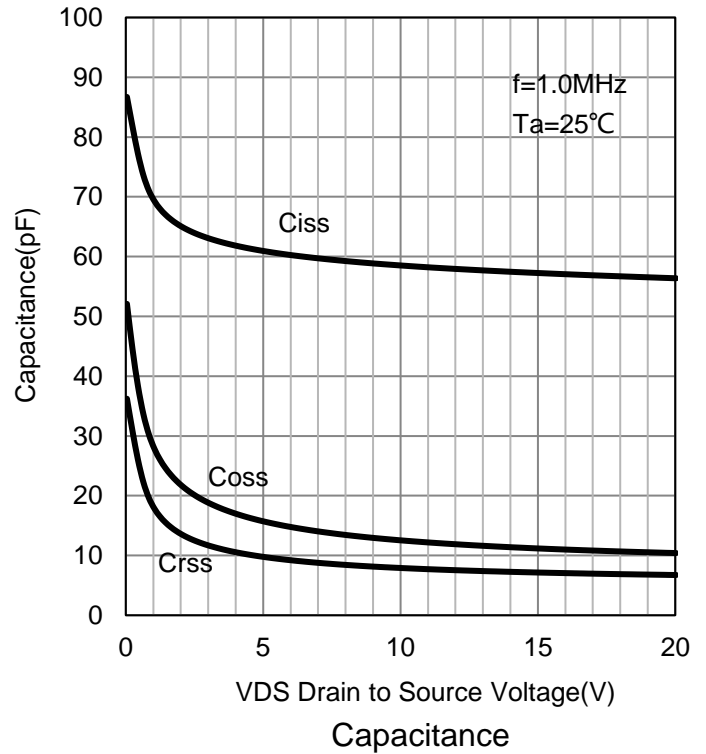
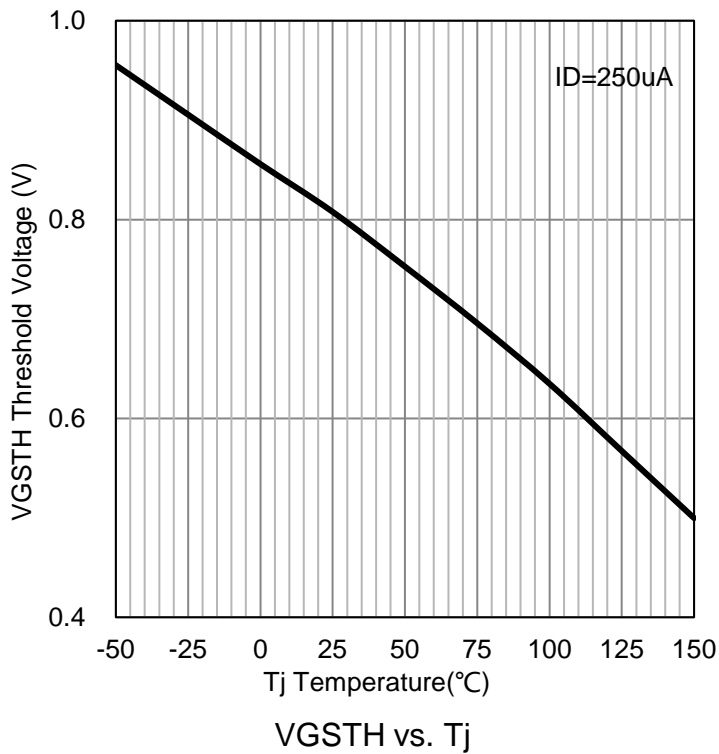
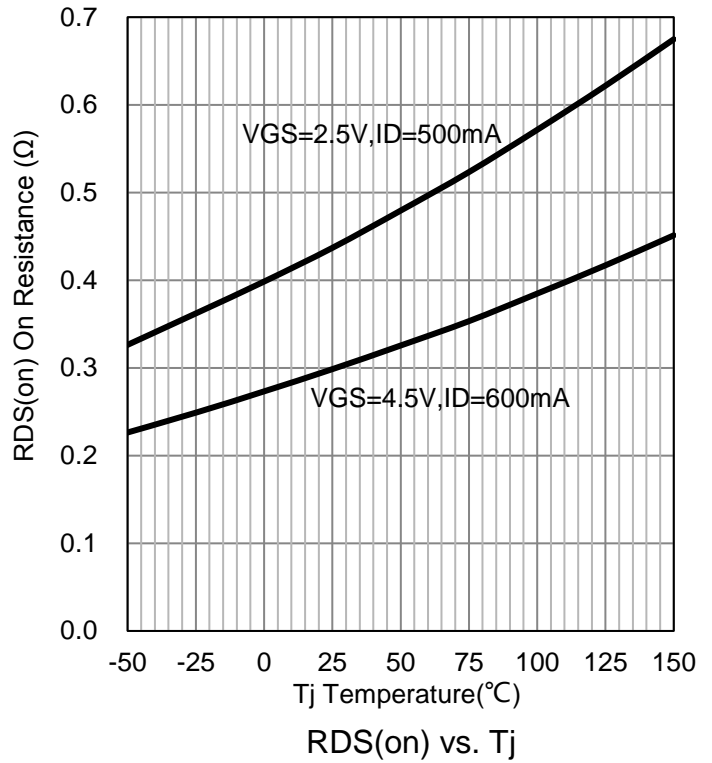
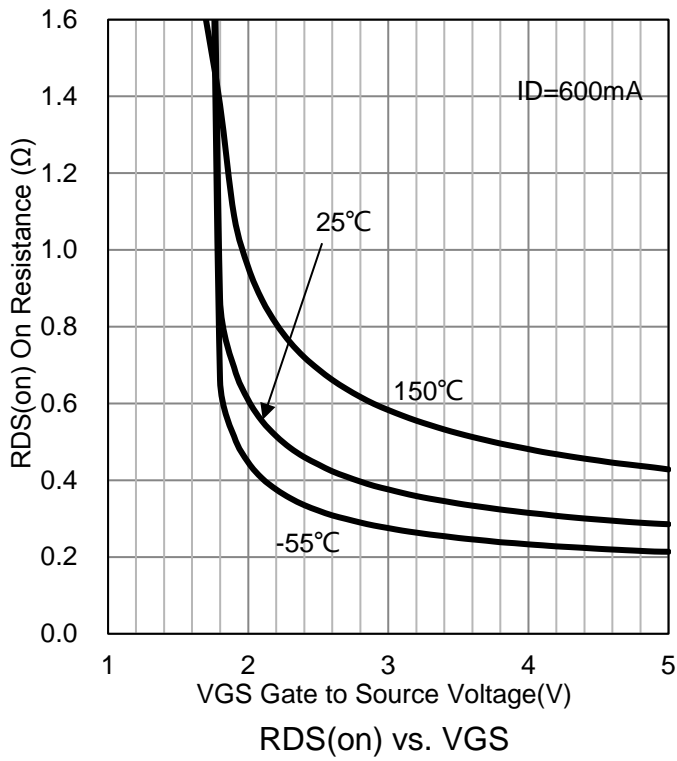

### 7. OUTLINE AND DIMENSIONS

Notes:

1. DIMENSIONING AND TOLERANCING PER ANSI Y14.5M, 1982.
2. CONTROLLING DIMENSION: MILLIMETERS.
3. MAXIMUM LEAD THICKNESS INCLUDES LEAD FINISH. MINIMUM LEAD THICKNESS IS THE MINIMUM THICKNESS OF BASE MATERIAL.
4. DIMENSIONS A AND B DO NOT INCLUDE MOLD FLASH, PROTRUSIONS OR GATE BURRS.

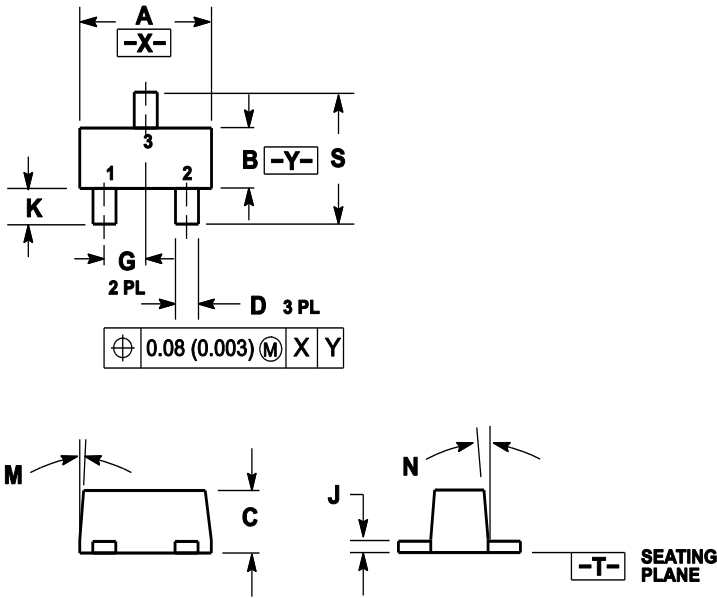

DIM	MILLIMETERS			INCHES		
	MIN	NOM	MAX	MIN	NOM	MAX
A	1.50	1.60	1.70	0.059	0.063	0.067
B	0.75	0.85	0.95	0.030	0.034	0.040
C	0.60	0.70	0.80	0.024	0.028	0.031
D	0.23	0.28	0.33	0.009	0.011	0.013
G	0.50BSC			0.020BSC		
H	0.53REF			0.021REF		
J	0.10	0.15	0.20	0.004	0.006	0.008
K	0.30	0.40	0.50	0.012	0.016	0.02
L	1.10REF			0.043REF		
M	---	---	10°	---	---	10°
N	---	---	10°	---	---	10°
S	1.50	1.60	1.70	0.059	0.063	0.067

### 8. SOLDERING FOOTPRINT

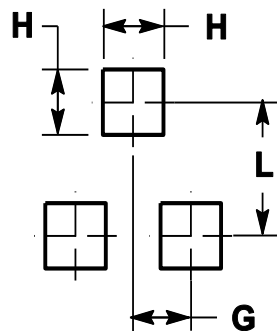

单击下面可查看定价，库存，交付和生命周期等信息

[>>LRC\(乐山无线电\)](#)

[>>点击查看相关商品](#)