

# SMDJ\*\*\* A Series

SURFACE MOUNT TRANSIENT VOLTAGE SUPPRESSOR  
VOLTAGE 5 TO 250 Volts, 3000 Watt Peak Pulse Power

## 1. FEATURES

- We declare that the material of product compliance with RoHS requirements and Halogen Free.
- Plastic package has Underwriters Laboratory Flammability Classification 94V-O
- For surface mounted applications in order to optimize board space
- Low profile package
- Built-in strain relief
- Glass passivated junction
- Low inductance
- Excellent clamping capability
- Repetition Rate (duty cycle): 0.01%
- Fast response time: typically less than 1.0ps
- Typical IR less than 1mA above 10V
- High temperature soldering guaranteed:  
260°C/10 seconds,
- Weight: 0.26g

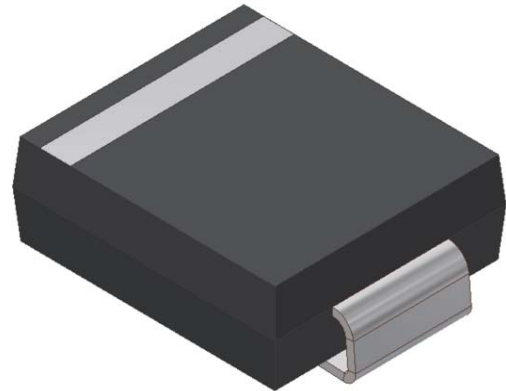

## 2. MECHANICAL DATA

**Case:** JEDEC DO-214AB (SMC)

**Terminals:** Plated leads, solderable per MIL-STD-202, Method 208

**Polarity:** With Color band denoted cathode

**Mounting Position:** Any

## 3. MAXIMUM RATINGS (Ta = 25°C)

Ratings at 25°C ambient temperature unless otherwise specified.

Single phase, half wave, 60Hz, resistive or inductive load.

For capacitive load, derate current by 20%.

RATING	Symbol	VALUE	UNITS
Peak Power Dissipation at $T_A=25^\circ\text{C}$ , $T_P=1\text{ms}$ (Note 1)	$P_{PPM}$	Minimum 3000	Watts
Steady State Power Dissipation at $T_L=75^\circ\text{C}$ (Note 2)	$P_{M(AV)}$	6.5	Watts
Peak Forward Surge Current, 8.3ms Single Half Sine-Wave Superimposed on Rated Load, (JEDEC Method)(Note 3)	$I_{FSM}$	300	A
Typical thermal resistance (Note 2)	$R_{\theta JA}$	80	°C/W
	$R_{\theta JC}$	20	
Operating Temperature Range	$T_J$	-55 to +150	°C
Storage Temperature Range	$T_{STG}$	-55 to +150	°C

NOTES:

1. Non-repetitive current pulse, per Fig. 3 and derated above  $T_A=25^\circ\text{C}$  per Fig. 2.
2. Mounted on 0.31 x 0.31" (8.0 x 8.0mm) copper pads to each terminal.
3. 8.3ms single half sine-wave, duty cycle= 4 pulses per minu

## SMDJ\*\*\* A Series

Uni-Directional Part Number	Device marking code	Reverse Stand-off Voltage VRWM (V)	Breakdown Voltage VBR (V) Min. @IT	Breakdown Voltage VBR (V) Max. @IT	Test Current IT (mA)	Maximum Clamping Voltage @IPP VC (V)	Peak Pulse Current Ipp (A)	Reverse Leakage @VRWM IR (uA)
SMDJ5.0A	SMDJ5.0A	5.00	6.40	7.00	10.00	9.20	326.1	800
SMDJ6.0A	SMDJ6.0A	6.00	6.67	7.37	10.00	10.30	291.3	800
SMDJ6.5A	SMDJ6.5A	6.50	7.22	7.98	10.00	11.20	267.9	500
SMDJ7.0A	SMDJ7.0A	7.00	7.78	8.60	10.00	12.00	250.0	200
SMDJ7.5A	SMDJ7.5A	7.50	8.33	9.21	1.00	12.90	232.6	100
SMDJ8.0A	SMDJ8.0A	8.00	8.89	9.83	1.00	13.60	220.6	50
SMDJ8.5A	SMDJ8.5A	8.50	9.44	10.40	1.00	14.40	208.3	20
SMDJ9.0A	SMDJ9.0A	9.00	10.00	11.10	1.00	15.40	194.8	10
SMDJ10A	SMDJ10A	10.00	11.10	12.30	1.00	17.00	176.5	1
SMDJ11A	SMDJ11A	11.00	12.20	13.50	1.00	18.20	164.8	1
SMDJ12A	SMDJ12A	12.00	13.30	14.70	1.00	19.90	150.8	1
SMDJ13A	SMDJ13A	13.00	14.40	15.90	1.00	21.50	139.5	1
SMDJ14A	SMDJ14A	14.00	15.60	17.20	1.00	23.20	129.3	1
SMDJ15A	SMDJ15A	15.00	16.70	18.50	1.00	24.40	123.0	1
SMDJ16A	SMDJ16A	16.00	17.80	19.70	1.00	26.00	115.4	1
SMDJ17A	SMDJ17A	17.00	18.90	20.90	1.00	27.60	108.7	1
SMDJ18A	SMDJ18A	18.00	20.00	22.10	1.00	29.20	102.7	1
SMDJ20A	SMDJ20A	20.00	22.20	24.50	1.00	32.40	92.6	1
SMDJ22A	SMDJ22A	22.00	24.40	26.90	1.00	35.50	84.5	1
SMDJ24A	SMDJ24A	24.00	26.70	29.50	1.00	38.90	77.1	1
SMDJ26A	SMDJ26A	26.00	28.90	31.90	1.00	42.10	71.3	1
SMDJ28A	SMDJ28A	28.00	31.10	34.40	1.00	45.40	66.1	1
SMDJ30A	SMDJ30A	30.00	33.30	36.80	1.00	48.40	62.0	1
SMDJ33A	SMDJ33A	33.00	36.70	40.60	1.00	53.30	56.3	1
SMDJ36A	SMDJ36A	36.00	40.00	44.20	1.00	58.10	51.6	1
SMDJ40A	SMDJ40A	40.00	44.40	49.10	1.00	64.50	46.5	1
SMDJ43A	SMDJ43A	43.00	47.80	52.80	1.00	69.40	43.2	1
SMDJ45A	SMDJ45A	45.00	50.00	55.30	1.00	72.70	41.3	1
SMDJ48A	SMDJ48A	48.00	53.30	58.90	1.00	77.40	38.8	1
SMDJ51A	SMDJ51A	51.00	56.70	62.70	1.00	82.40	36.4	1
SMDJ54A	SMDJ54A	54.00	60.00	66.30	1.00	87.10	34.4	1
SMDJ58A	SMDJ58A	58.00	64.40	71.20	1.00	93.60	32.1	1
SMDJ60A	SMDJ60A	60.00	66.70	73.70	1.00	96.80	31.0	1
SMDJ64A	SMDJ64A	64.00	71.10	78.60	1.00	103.00	29.1	1
SMDJ70A	SMDJ70A	70.00	77.80	86.00	1.00	113.00	26.5	1
SMDJ75A	SMDJ75A	75.00	83.30	92.10	1.00	121.00	24.8	1
SMDJ78A	SMDJ78A	78.00	86.70	95.80	1.00	126.00	23.8	1
SMDJ85A	SMDJ85A	85.00	94.40	104.00	1.00	137.00	21.9	1
SMDJ90A	SMDJ90A	90.00	100.00	111.00	1.00	146.00	20.5	1
SMDJ100A	SMDJ100A	100.00	111.00	123.00	1.00	162.00	18.5	1
SMDJ110A	SMDJ110A	110.00	122.00	135.00	1.00	177.00	16.9	1
SMDJ120A	SMDJ120A	120.00	133.00	147.00	1.00	193.00	15.5	1
SMDJ130A	SMDJ130A	130.00	144.00	159.00	1.00	209.00	14.4	1
SMDJ150A	SMDJ150A	150.00	167.00	185.00	1.00	243.00	12.3	1
SMDJ160A	SMDJ160A	160.00	178.00	197.00	1.00	259.00	11.6	1
SMDJ170A	SMDJ170A	170.00	189.00	209.00	1.00	275.00	10.9	1
SMDJ180A	SMDJ180A	180.00	198.00	221.00	1.00	291.00	10.3	1
SMDJ190A	SMDJ190A	190.00	209.00	233.00	1.00	307.00	9.8	1
SMDJ200A	SMDJ200A	200.00	220.00	246.00	1.00	324.00	9.3	1
SMDJ220A	SMDJ220A	220.00	246.00	272.00	1.00	356.00	8.4	1
SMDJ250A	SMDJ250A	250.00	279.00	309.00	1.00	405.00	7.4	1

### 5. ELECTRICAL CHARACTERISTICS CURVES

Fig. 1-Peak Pulse Power Rating Curve

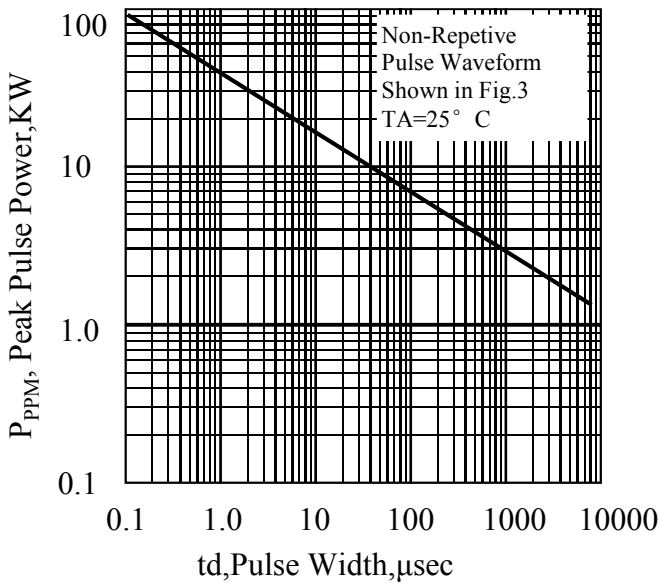

Fig. 2-Pulse Derating Curve

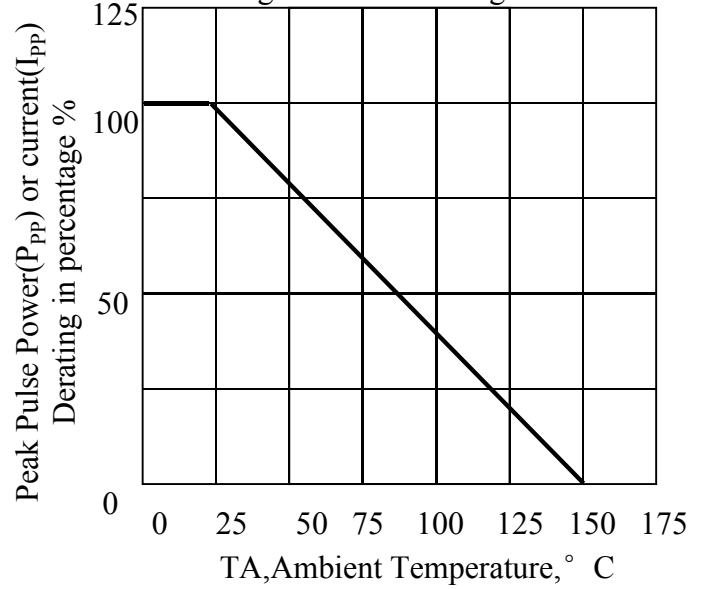

Fig. 3-Pulse Waveform

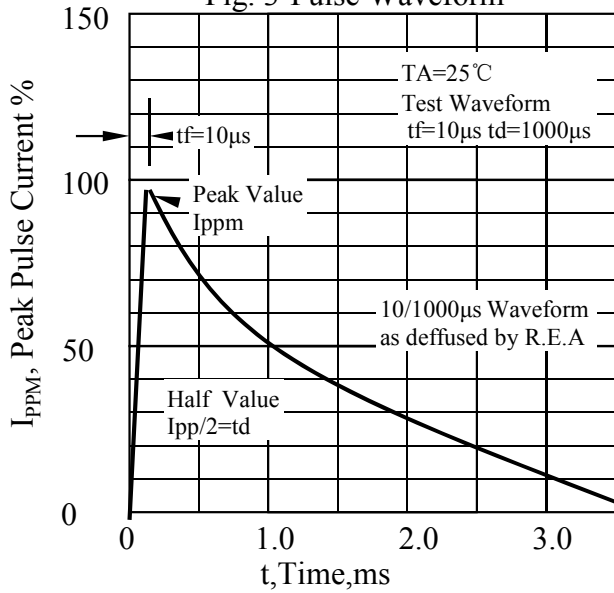

Fig. 4-Typical Junction Capacitance

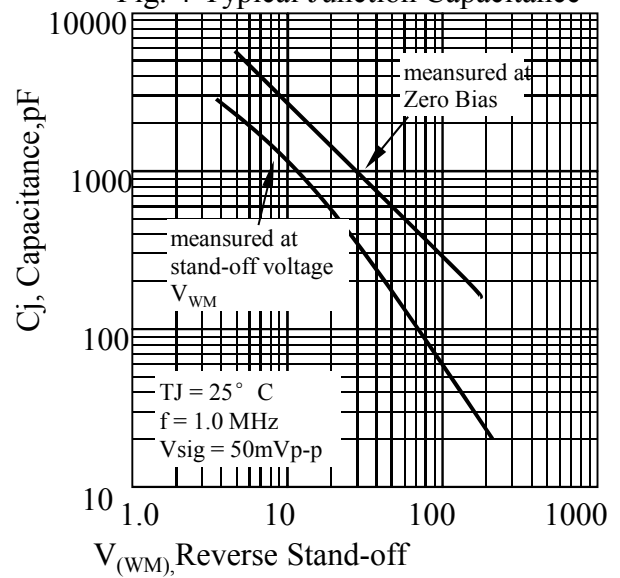
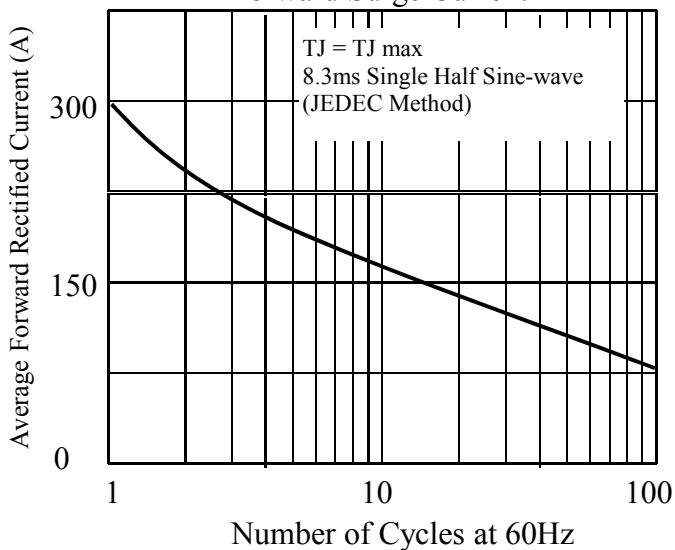
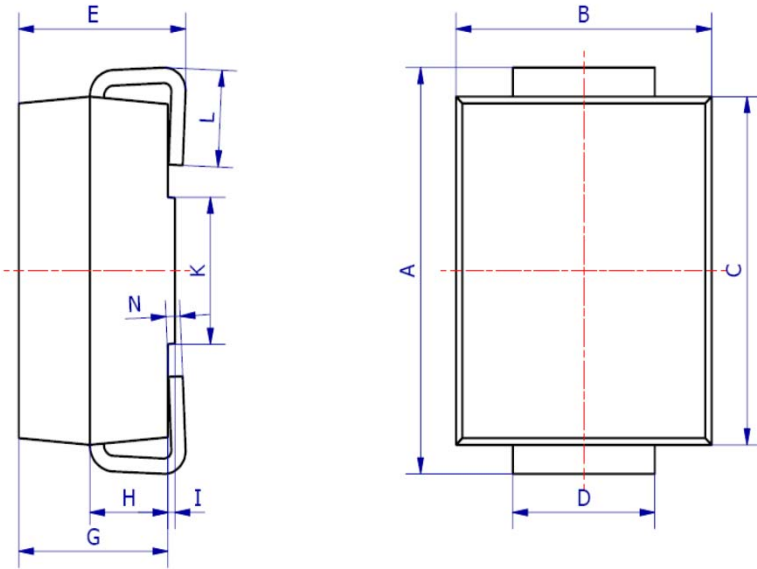

Fig. 5 - Maximum Non-repetitive Peak Forward Surge Current



### 6. OUTLINE AND DIMENSIONS



SMC			
DIM	Min	Max	Typ.
A	7.70	8.30	8.00
B	5.85	6.25	6.05
C	6.65	7.05	6.85
D	2.80	3.20	3.00
E	2.45	2.85	2.65
G	2.10	2.50	2.30
H	1.00	1.40	1.20
I	0.05	0.15	0.10
K	4.30	4.70	4.50
L	1.00	1.50	1.25
N	0.10	0.30	0.20
All Dimensions in mm			

### 7. SOLDERING FOOTPRINT

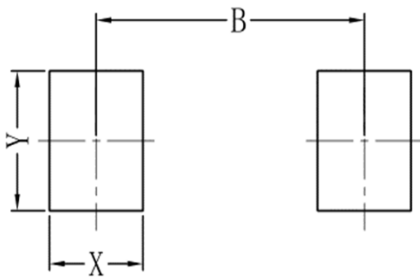

SMC	
DIM	(mm)
X	1.60
Y	3.30
B	6.60

单击下面可查看定价，库存，交付和生命周期等信息

[>>LRC\(乐山无线电\)](#)