

## Programmable Precision Reference

# LR431AOT1G

### DESCRIPTION

The LR431 is a three-terminal adjustable regulator with a guaranteed thermal stability over applicable temperature ranges. The output voltage may be set to any value between  $V_{ref}$  (approximately 2.5V) and 36V with two external resistors. It provides very wide applications, including shunt regulator, series regulator, switching regulator, voltage reference and others.

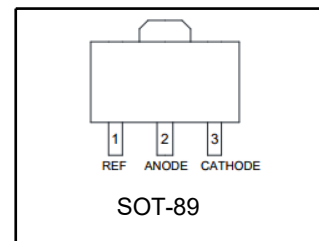

Pin 2 is connected internally to ANODE (die substrate) and should be floating or connected to ANODE.

### FEATURES

- Low Dynamic output impedance 0.1 $\Omega$  (Typ)
- Adjustable output voltage
- Fast turn-on response
- Sink current capability of 0.1mA to 100mA
- Low output noise
- Industrial temperature range
- Electrostatic discharge voltage 2.5kV

### BLOCK DIAGRAM

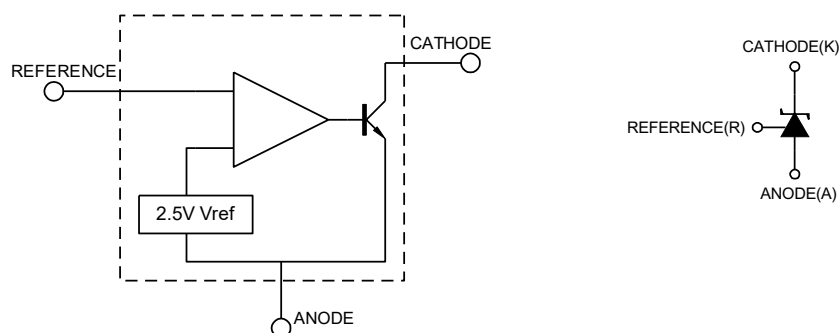

**ABSOLUTE MAXIMUM RATINGS** (Operating temperature range applies unless otherwise specified)

PARAMETER	SYMBOL	VALUE	UNIT
Cathode Voltage	V <sub>KA</sub>	36	V
Cathode Current Range(Continuous)	I <sub>KA</sub>	-100 ~ +150	mA
Reference Input Current Range	I <sub>ref</sub>	-0.05 ~ +10	mA
Operating Junction Temperature	T <sub>j</sub>	150	°C
Thermal Resistance	θ <sub>JA</sub>	250	°C/W
Operating Ambient Temperature	T <sub>opr</sub>	-40 ~ +125	°C
Storage Temperature	T <sub>stg</sub>	-65 ~ +150	°C

**RECOMMENDED OPERATING CONDITIONS**

PARAMETER	SYMBOL	MIN	TYP	MAX	UNIT
Cathode Voltage	V <sub>KA</sub>	V <sub>REF</sub>		36	V
Cathode Current	I <sub>KA</sub>	0.3		100	mA

**ELECTRICAL CHARACTERISTICS**(T<sub>a</sub>=25°C, unless otherwise specified)

Characteristic		Symbol	Test Conditions	Min	Typ	Max	Unit	
Reference Input Voltage	0.5%	V <sub>ref</sub>	V <sub>KA</sub> =V <sub>REF</sub> , I <sub>KA</sub> =10mA	2.487	2.500	2.512	V	
Deviation of reference Input Voltage Over temperature		ΔV <sub>ref</sub>	V <sub>KA</sub> =V <sub>REF</sub> , I <sub>KA</sub> =10mA T <sub>MIN</sub> ≤T <sub>A</sub> ≤T <sub>MAX</sub>		15	35	mV	
			V <sub>KA</sub> =V <sub>REF</sub> , I <sub>KA</sub> =10mA T <sub>A</sub> =0 to 125°C		8	17	mV	
Ratio of Change in Reference Input Voltage to the Change in Cathode Voltage		ΔV <sub>ref</sub> /ΔV <sub>KA</sub>	I <sub>KA</sub> =10mA	ΔV <sub>KA</sub> =10V~V <sub>REF</sub>	-2.7	-1.0		mV/V
				ΔV <sub>KA</sub> =36V~10V	-2	-0.4		
Reference Input Current		I <sub>ref</sub>	I <sub>KA</sub> =10mA, R <sub>1</sub> =10kΩ, R <sub>2</sub> =∞		0.5	1.2	μA	
Deviation of Reference Input Current Over Full Temperature Range		ΔI <sub>ref</sub> /ΔT	I <sub>KA</sub> =10mA, R <sub>1</sub> =10kΩ, R <sub>2</sub> =∞ T <sub>A</sub> =full Temperature		0.4	1.2	μA	
Minimum cathode current for regulation		I <sub>KA</sub> (min)	V <sub>KA</sub> =V <sub>REF</sub>		0.08	0.3	mA	
Off-state cathode Current		I <sub>KA</sub> (OFF)	V <sub>KA</sub> =36V, V <sub>REF</sub> =0		0.01	0.8	μA	
Dynamic Impedance		Z <sub>KA</sub>	V <sub>KA</sub> =V <sub>REF</sub> , I <sub>KA</sub> =0.2 to 100mA f <sub>≤</sub> 1.0kHz		0.1	0.37	Ω	

**CLASSIFICATION OF V<sub>ref</sub> AND PACKAGE**

Type	RanK	Range(V)	Marking
LR431AOT1G	0.5%	2.487~2.512	RAO
LR431APOT1G	0.5%	2.483~2.507	RBO

Package: SOT89

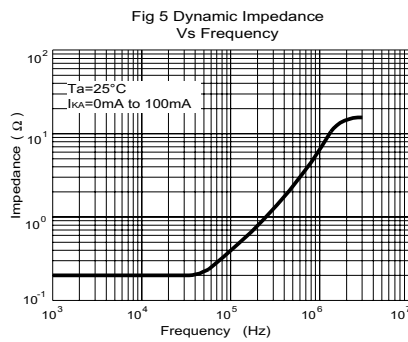
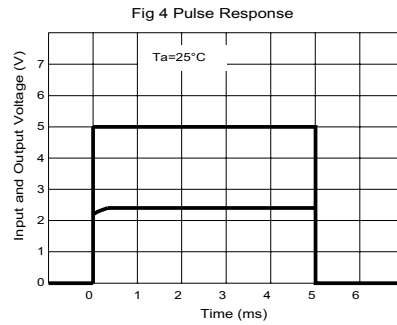
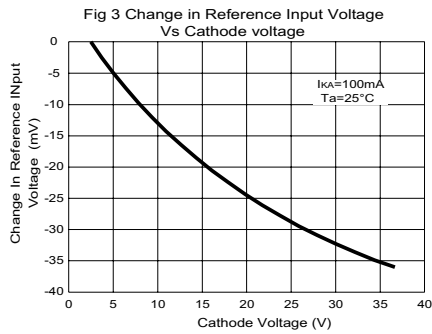
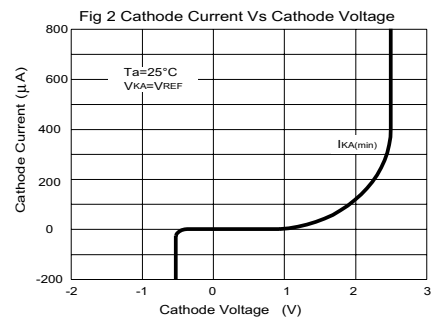
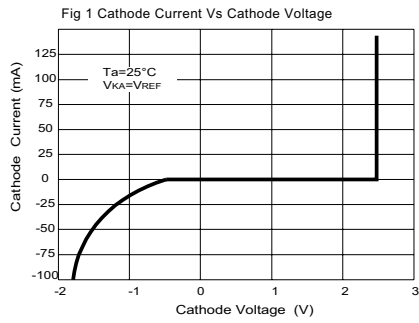
**TYPICAL PERFORMANCE CHARACTERISTICS**

**TEST CIRCUIT**

 Fig 6 Test Circuit For  $V_{KA}=V_{REF}$ 

 Fig 7 Test Circuit for  $V_{KA} \geq V_{REF}$ 

 Fig 8 Test Circuit For  $I_{KA(OFF)}$ 
**APPLICATION CIRCUIT**

Fig 9 Shutdown Regulator

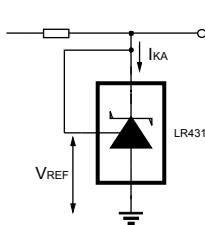
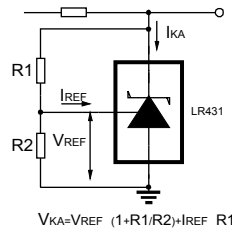
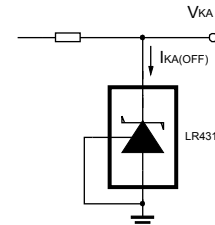
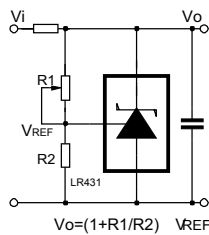
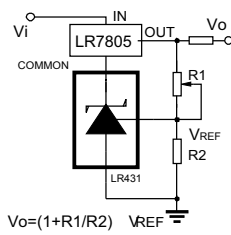

Fig 10 Output Control of a Three-Terminal Fixed Regulator

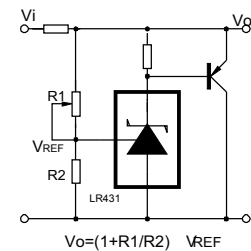

Fig 11 Higher-current Shunt Regulator

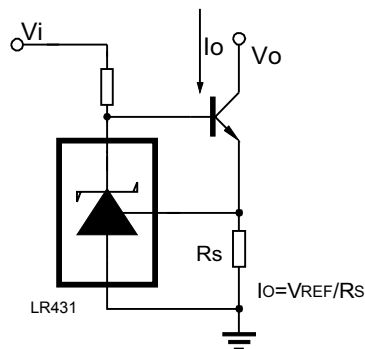

Fig 12 Constant-current Sink

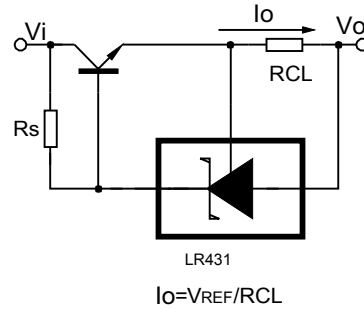
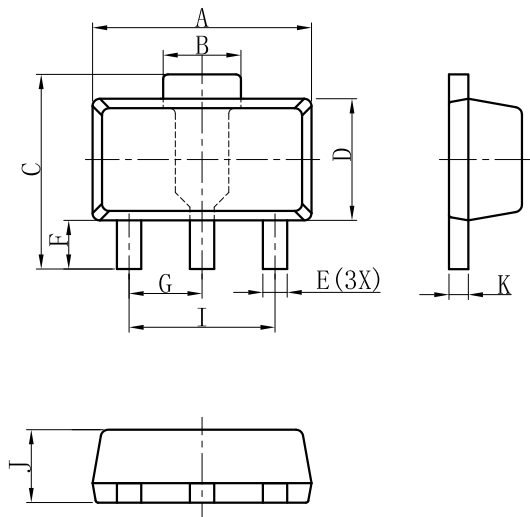

Fig 13 Current Limiting or Current Source

## Package Outline Dimension

### SOT89



SOT89			
DIM	MIN	NOR	MAX
A	4.30	4.50	4.70
B	1.40	1.60	1.80
C	3.90	4.00	4.25
D	2.30	2.50	2.70
E	0.40	0.50	0.58
F	0.90	1.00	1.20
G	1.50 BSC		
I	3.00 BSC		
J	1.40	1.50	1.60
K	0.34	0.40	0.50
All Dimensions in mm			

#### GENERAL NOTES

1. Top package surface finish  $Ra0.4 \pm 0.2 \mu m$
2. Bottom package surface finish  $Ra0.7 \pm 0.2 \mu m$
3. Side package surface finish  $Ra0.4 \pm 0.2 \mu m$
4. Protrusion or Gate Burrs shall not exceed 0.10mm per side.

## Suggested Pad layout

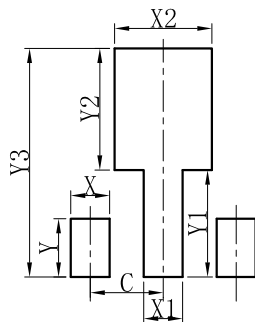

SOT89	
DIM	(mm)
X	0.80
Y	1.20
X1	0.80
Y1	2.20
X2	2.00
Y2	2.50
C	1.50
Y3	4.70

单击下面可查看定价，库存，交付和生命周期等信息

[>>LRC\(乐山无线电\)](#)