

# DUAL SMALL SIGNAL SURFACE MOUNT TRANSISTOR

- We declare that the material of product compliance with RoHS requirements.
- S- Prefix for Automotive and Other Applications Requiring Unique Site and Control Change Requirements; AEC-Q101 Qualified and PPAP Capable.

## ORDERING INFORMATION

Device	Marking	Shipping
LMBT4403DW1T1G S-LMBT4403DW1T1G	2T	3000/Tape&Reel
LMBT4403DW1T3G S-LMBT4403DW1T3G	2T	10000/Tape&Reel

## MAXIMUM RATINGS

Rating	Symbol	Value	Unit
Collector–Emitter Voltage	$V_{CEO}$	-40	Vdc
Collector–Base Voltage	$V_{CBO}$	-40	Vdc
Emitter–Base Voltage	$V_{EBO}$	-5.0	Vdc
Collector Current — Continuous	$I_C$	-600	mAdc

## THERMAL CHARACTERISTICS

Characteristic	Symbol	Max	Unit
Total Package Dissipation <sup>(1)</sup> $T_A = 25^\circ\text{C}$	$P_D$	150	mW
Thermal Resistance Junction to Ambient	$R_{\theta JA}$	833	$^\circ\text{C/W}$
Junction and Storage Temperature Range	$T_J, T_{stg}$	-55 to +150	$^\circ\text{C}$

## DEVICE MARKING

LMBT4403DW1T1G=2T

## ELECTRICAL CHARACTERISTICS ( $T_A = 25^\circ\text{C}$ unless otherwise noted)

Characteristic	Symbol	Min	Max	Unit
----------------	--------	-----	-----	------

## OFF CHARACTERISTICS

Collector–Emitter Breakdown Voltage (3) ( $I_C = -1.0\text{ mAdc}, I_B = 0$ )	$V_{(BR)CEO}$	-40	—	Vdc
Collector–Base Breakdown Voltage ( $I_C = -0.1\text{ mAdc}, I_E = 0$ )	$V_{(BR)CBO}$	-40	—	Vdc
Emitter–Base Breakdown Voltage ( $I_E = -0.1\text{ mAdc}, I_C = 0$ )	$V_{(BR)EBO}$	-5.0	—	Vdc
Base Cutoff Current ( $V_{CE} = -35\text{ Vdc}, V_{EB} = -0.4\text{ Vdc}$ )	$I_{BEV}$	—	-0.1	$\mu\text{Adc}$
Collector Cutoff Current ( $V_{CE} = -35\text{ Vdc}, V_{EB} = -0.4\text{ Vdc}$ )	$I_{CEX}$	—	-0.1	$\mu\text{Adc}$

- FR-5 = 1.0 x 0.75 x 0.062 in.
- Alumina = 0.4 x 0.3 x 0.024 in. 99.5% alumina.
- Pulse Test: Pulse Width  $\leq 300\ \mu\text{s}$ ; Duty Cycle  $\leq 2.0\%$ .

## LMBT4403DW1T1G S-LMBT4403DW1T1G

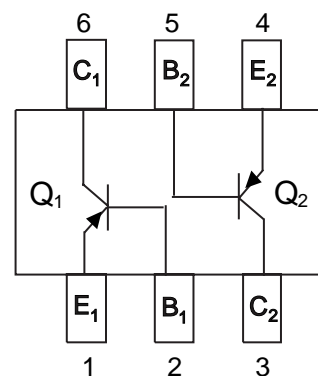
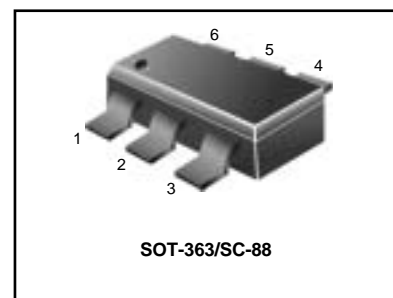

**ELECTRICAL CHARACTERISTICS** ( $T_A = 25^\circ\text{C}$  unless otherwise noted) (Continued)

Characteristic	Symbol	Min	Max	Unit
<b>ON CHARACTERISTICS</b>				
DC Current Gain ( $I_C = -0.1 \text{ mAdc}, V_{CE} = -1.0 \text{ Vdc}$ ) ( $I_C = -1.0 \text{ mAdc}, V_{CE} = -1.0 \text{ Vdc}$ ) ( $I_C = -10 \text{ mAdc}, V_{CE} = -1.0 \text{ Vdc}$ ) ( $I_C = -150 \text{ mAdc}, V_{CE} = -2.0 \text{ Vdc}$ )(3) ( $I_C = -500 \text{ mAdc}, V_{CE} = -2.0 \text{ Vdc}$ )(3)	$h_{FE}$	30 60 100 100 20	— — — 300 —	—
Collector–Emitter Saturation Voltage(3) ( $I_C = -150\text{mAdc}, I_B = -15 \text{ mAdc}$ ) ( $I_C = -500 \text{ mAdc}, I_B = -50 \text{ mAdc}$ )	$V_{CE(sat)}$	— —	-0.4 -0.75	Vdc
Base–Emitter Saturation Voltage (3) ( $I_C = -150 \text{ mAdc}, I_B = -15 \text{ mAdc}$ ) ( $I_C = -500 \text{ mAdc}, I_B = -50 \text{ mAdc}$ )	$V_{BE(sat)}$	-0.75 —	-0.95 -1.3	Vdc

**SMALL-SIGNAL CHARACTERISTICS**

Current–Gain — Bandwidth Product ( $I_C = -20\text{mAdc}, V_{CE} = -10 \text{ Vdc}, f = 100 \text{ MHz}$ )	$f_T$	200	—	MHz
Collector–Base Capacitance ( $V_{CB} = -10 \text{ Vdc}, I_E = 0, f = 1.0 \text{ MHz}$ )	$C_{cb}$	—	8.5	pF
Emitter–Base Capacitance ( $V_{BE} = -0.5 \text{ Vdc}, I_C = 0, f = 1.0 \text{ MHz}$ )	$C_{eb}$	—	30	pF
Input Impedance ( $V_{CE} = -10 \text{ Vdc}, I_C = -1.0 \text{ mAdc}, f = 1.0 \text{ kHz}$ )	$h_{ie}$	1.5	15	$k\Omega$
Voltage Feedback Ratio ( $V_{CE} = -10 \text{ Vdc}, I_C = -1.0 \text{ mAdc}, f = 1.0 \text{ kHz}$ )	$h_{re}$	0.1	8.0	$\times 10^{-4}$
Small–Signal Current Gain ( $V_{CE} = -10 \text{ Vdc}, I_C = -1.0 \text{ mAdc}, f = 1.0 \text{ kHz}$ )	$h_{fe}$	60	500	—
Output Admittance ( $V_{CE} = -10 \text{ Vdc}, I_C = -1.0 \text{ mAdc}, f = 1.0 \text{ kHz}$ )	$h_{oe}$	1.0	100	$\mu\text{mhos}$

**SWITCHING CHARACTERISTICS**

Delay Time	( $V_{CC} = -30 \text{ Vdc}, V_{EB} = -2.0 \text{ Vdc},$	$t_d$	—	15	ns
Rise Time	$I_C = -150\text{mAdc}, I_{B1} = -15 \text{ mAdc}$ )	$t_r$	—	20	
Storage Time	( $V_{CC} = -30 \text{ Vdc}, I_C = -150 \text{ mAdc},$	$t_s$	—	225	ns
Fall Time	$I_{B1} = I_{B2} = -15 \text{ mAdc}$ )	$t_f$	—	30	

3. Pulse Test: Pulse Width  $\leq 300 \mu\text{s}$ ; Duty Cycle  $\leq 2.0\%$ .

**SWITCHING TIME EQUIVALENT TEST CIRCUITS**

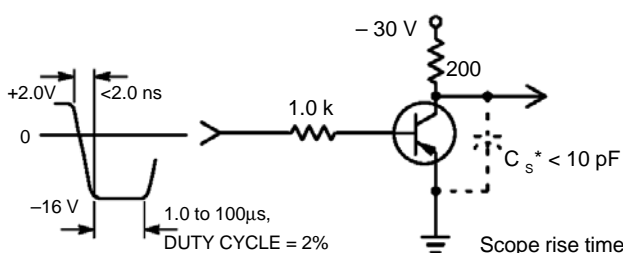

Figure 1. Turn–On Time

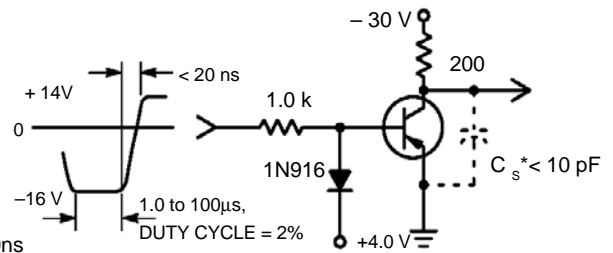

Figure 2. Turn–Off Time

\*Total shunt capacitance of test jig connectors, and oscilloscope

TYPICAL TRANSIENT CHARACTERISTICS

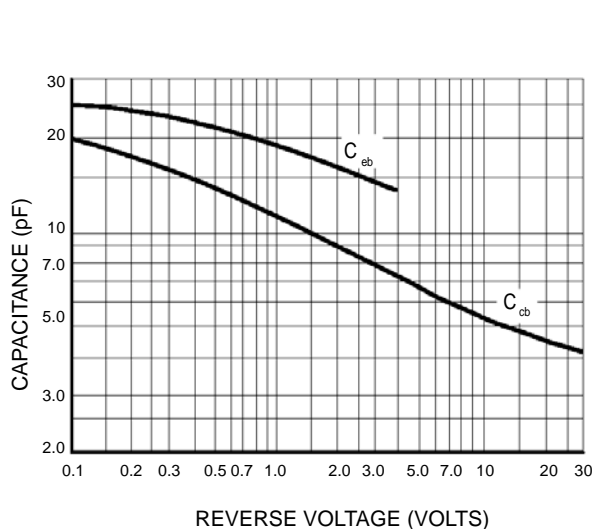

Figure 3. Capacitance

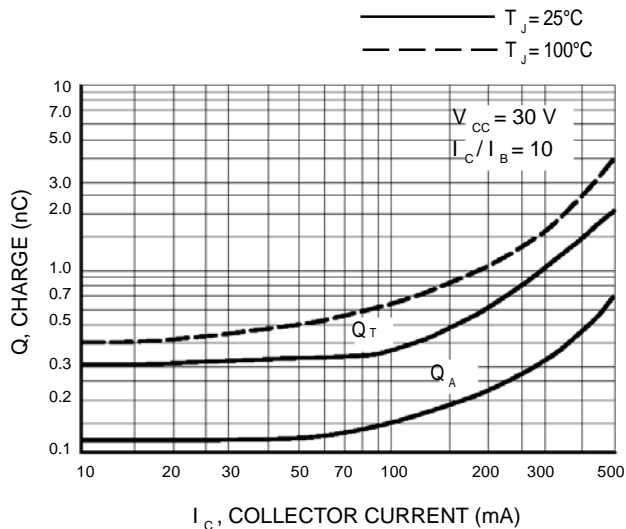

Figure 4. Charge Data

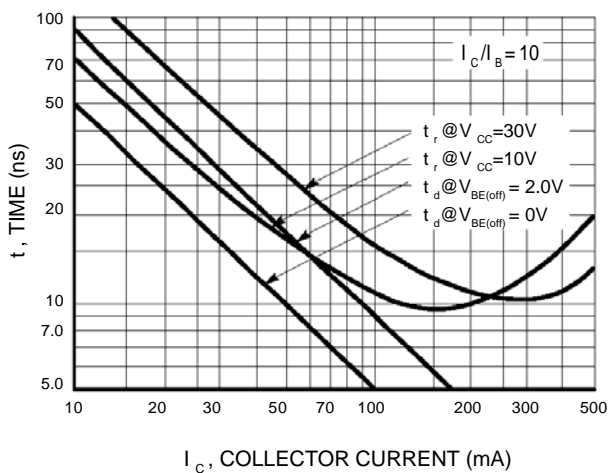

Figure 5. Turn-On Time

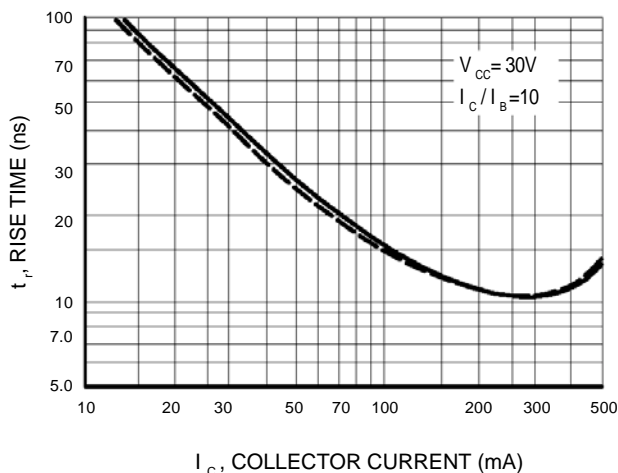

Figure 6. Rise Time

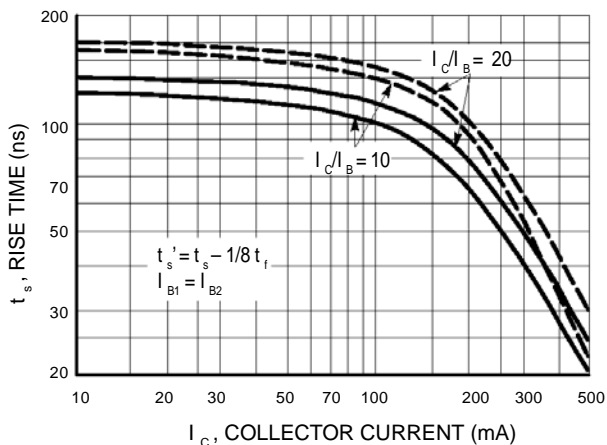

Figure 7. Storage Time

LMBT4403DW1T1G;S-LMBT4403DW1T1G

SMALL-SIGNAL CHARACTERISTICS

NOISE FIGURE

$V_{CE} = -10 \text{ Vdc}$ ,  $T_A = 25^\circ\text{C}$

Bandwidth = 1.0 Hz

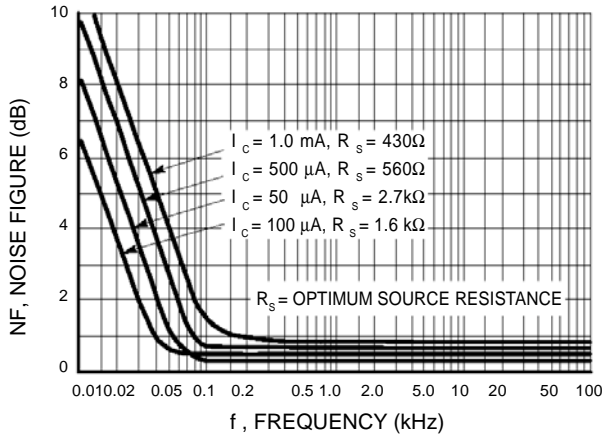

Figure 8. Frequency Effects

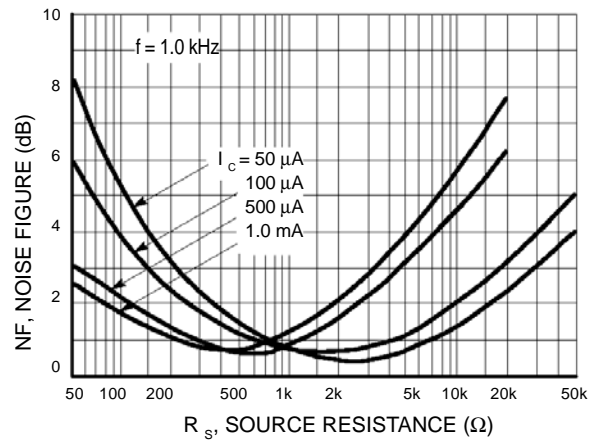

Figure 9. Source Resistance Effects

h PARAMETERS

( $V_{CE} = -10 \text{ Vdc}$ ,  $f = 1.0 \text{ kHz}$ ,  $T_A = 25^\circ\text{C}$ )

This group of graphs illustrates the relationship between  $h_{fe}$  and other "h" parameters for this series of transistors. To obtain these curves, a high-gain and a low-gain unit were selected from the MMBT4401LT1 lines, and the same units were used to develop the correspondingly numbered curves on each graph.

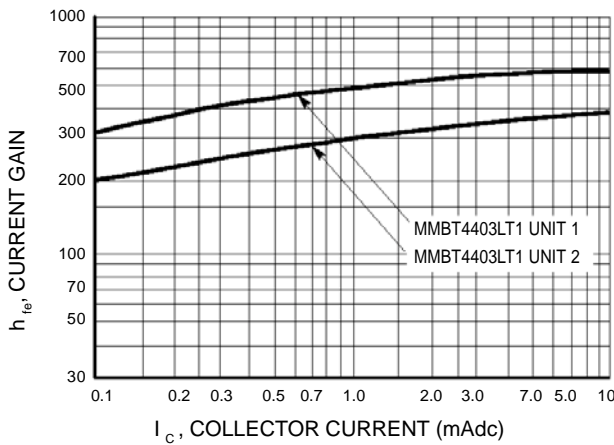

Figure 10. Current Gain

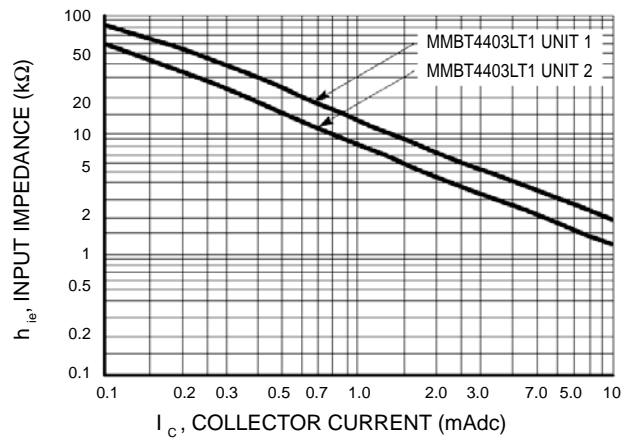

Figure 11. Input Impedance

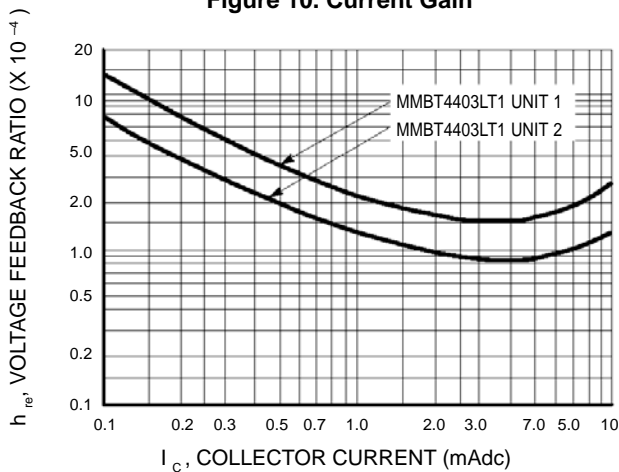

Figure 12. Voltage Feedback Ratio

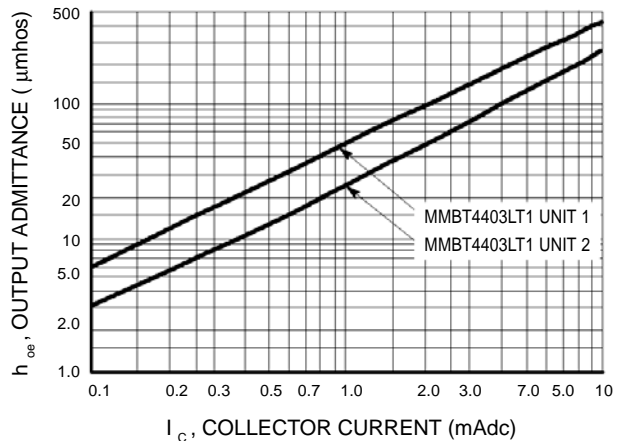

Figure 13. Output Admittance

STATIC CHARACTERISTICS

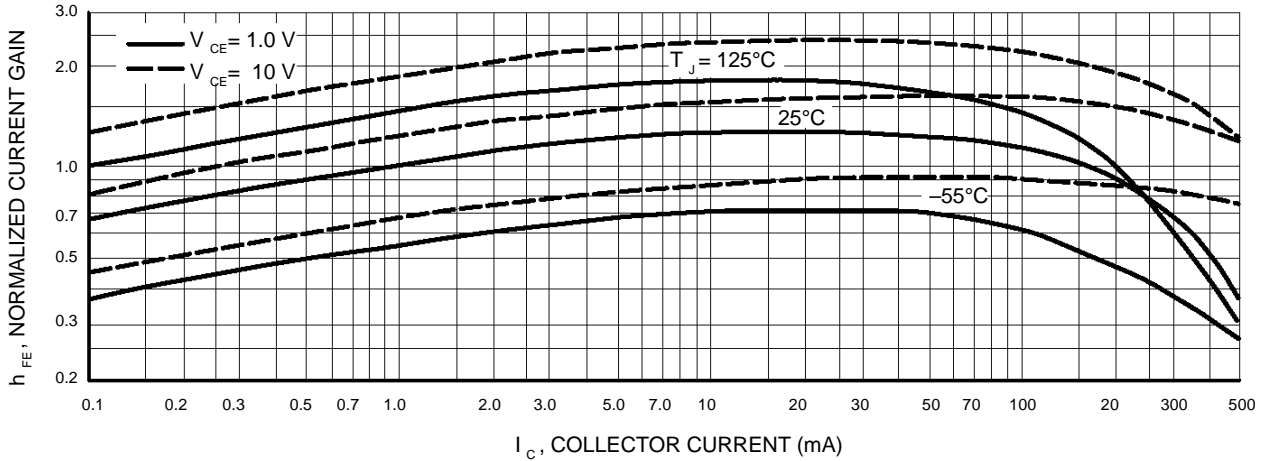

Figure 14. DC Current Gain

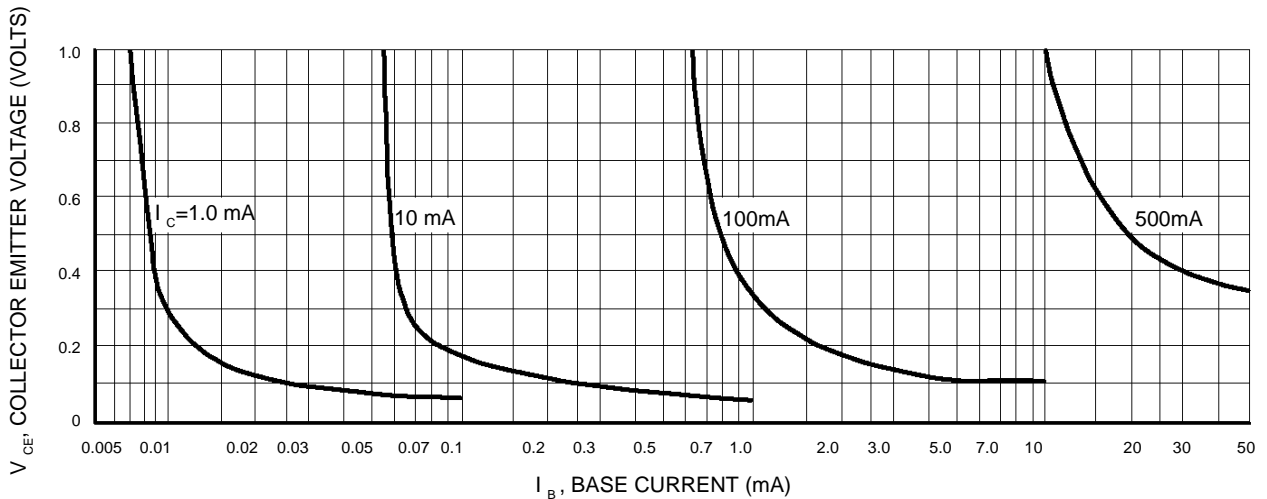

Figure 15. Collector Saturation Region

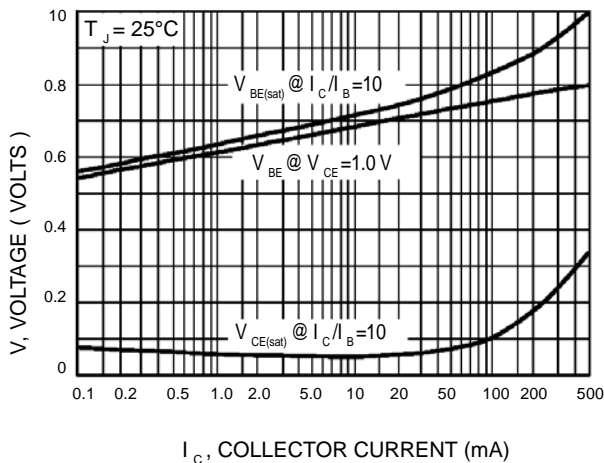

Figure 16. "On" Voltages

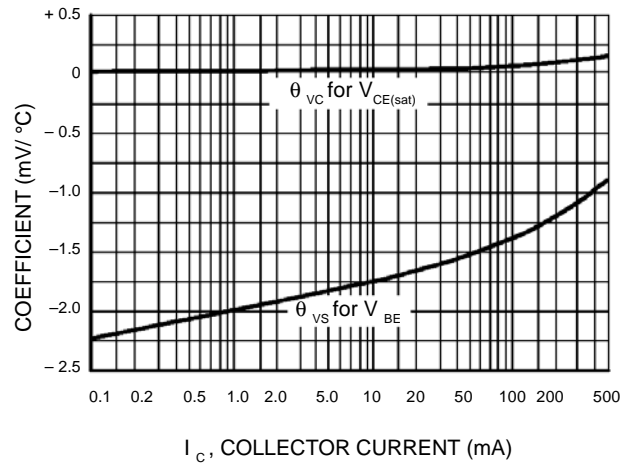
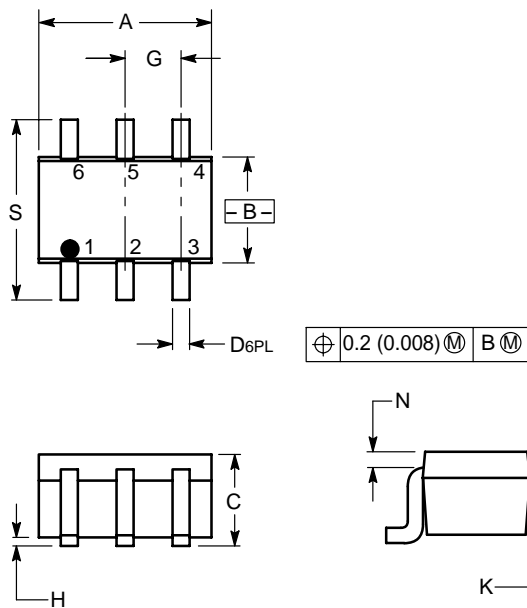

Figure 17. Temperature Coefficients

SC-88/SOT-363

NOTES:

1. DIMENSIONING AND TOLERANCING PER ANSI Y14.5M, 1982.
2. CONTROLLING DIMENSION: INCH.



DIM	INCHES		MILLIMETERS	
	MIN	MAX	MIN	MAX
A	0.071	0.087	1.80	2.20
B	0.045	0.053	1.15	1.35
C	0.031	0.043	0.80	1.10
D	0.004	0.012	0.10	0.30
G	0.026 BSC		0.65 BSC	
H	---	0.004	---	0.10
J	0.004	0.010	0.10	0.25
K	0.004	0.012	0.10	0.30
N	0.008 REF		0.20 REF	
S	0.079	0.087	2.00	2.20

- PIN 1. EMITTER 2  
 2. BASE 2  
 3. COLLECTOR 1  
 4. EMITTER 1  
 5. BASE 1  
 6. COLLECTOR 2

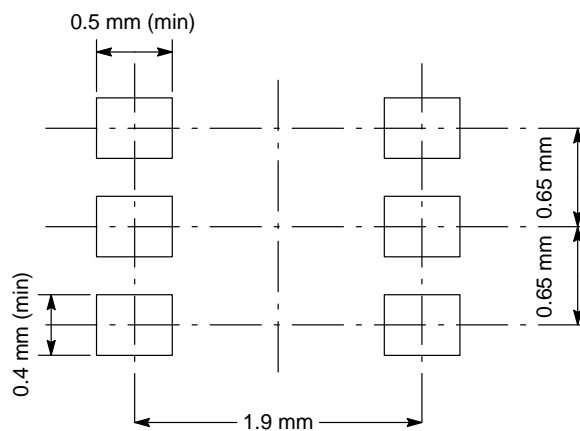

单击下面可查看定价，库存，交付和生命周期等信息

[>>LRC\(乐山无线电\)](#)