

LP2317DT2AG

20V P-Channel (D-S) MOSFET

1. FEATURES

- $V_{DS} = -20V$
 $R_{DS(ON)} \leq 26m\Omega, V_{GS}@-4.5V, I_{DS}@-7A$
 $R_{DS(ON)} \leq 36m\Omega, V_{GS}@-2.5V, I_{DS}@-5.6A$
- Low $R_{DS(ON)}$ trench technology.
- Low thermal impedance.
- Fast switching speed.
- We declare that the material of product compliance with RoHS requirements and Halogen Free.
- S- prefix for automotive and other applications requiring unique site and control change requirements; AEC-Q101 qualified and PPAP capable.

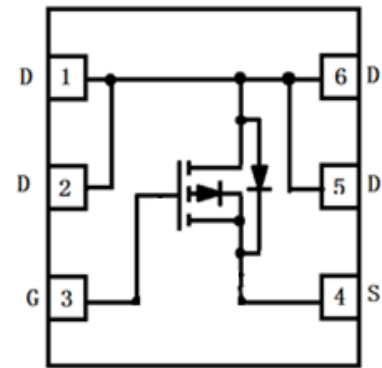
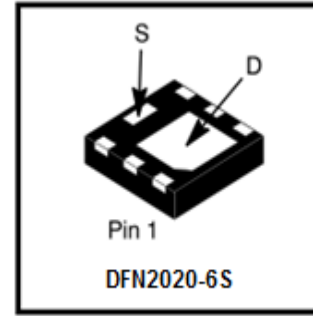

2. APPLICATIONS

- Load Switches
- DC/DC Conversion
- Motor Drives

3. DEVICE MARKING AND ORDERING INFORMATION

Device	Marking	Shipping
LP2317DT2AG	L1	4000/Tape&Reel

4. MAXIMUM RATINGS($T_a = 25^\circ C$)

Parameter	Symbol	Limits	Unit	
Drain-Source Voltage	V_{DS}	-20	V	
Gate-Source Voltage	V_{GS}	± 8		
Continuous Drain Current (Note1)	I_D	-8.8	A	
Pulsed Drain Current (Note2)	I_{DM}	-40		
Continuous Source Current (Diode Conduction) (Note1)	I_S	-5		
Power Dissipation (Note1)	PD	$T_A = 25^\circ C$	3	W
		$T_A = 70^\circ C$	1.9	
Operating Junction and Storage Temperature Range		T_J, T_{stg}	-55~+150	$^\circ C$
Maximum Junction-to-Ambient (Note1)	$t \leq 10 \text{ sec}$	R_{qJA}	40	$^\circ C/W$
	Steady State		90	

Note: 1. Surface Mounted on 1" x 1" FR4 Board.

2. Pulse width limited by maximum junction temperature

5. ELECTRICAL CHARACTERISTICS (Ta= 25°C)

Characteristic	Symbol	Min.	Typ.	Max.	Unit
Static					
Drain-Source Breakdown Voltage (VGS = 0V, ID = -250uA)	V(BR)DSS	-20	-	-	V
Gate Threshold Voltage (VDS =VGS , ID =-250μA)	VGS(th)	-0.4	-	-1.2	V
Gate Leakage Current (VDS =0V, VGS =±8V)	IGSS	-	-	±100	nA
Zero Gate Voltage Drain Current (VDS =-16V, VGS =0V)	IDSS	-	-	-1	μA
On-State Drain Current (Note 3) (VDS = -5 V, VGS = -4.5 V)	ID(on)	-12	-	-	A
Drain-Source On-Resistance (VGS = -4.5 V; ID = -7 A)	RDS(ON) (Note 3)	-	-	26	mΩ
Drain-Source On-Resistance (VGS = -2.5 V; ID = -5.6 A)		-	-	36	
Diode Forward Voltage (Note 3) (IS =-2.5 A, VGS =0V)	VSD	-	-	-1.3	V
Forward Transconductance (Note 3) (VDS = -15 V, ID = -7 A)	gfs	-	8	-	S
Dynamic (Note 4)					
Total Gate Charge	(VDS = -10 V, VGS = -4.5 V, ID = -7 A)	Qg	-	30	nC
Gate-Source Charge		Qgs	-	4	
Gate-Drain Charge		Qgd	-	6	
Turn-On Delay Time	(VDS = -10 V, RL = 1.4 Ω, ID = -7 A, VGEN = -4.5 V, RGEN = 6 Ω)	td(on)	-	6	ns
Rise Time		tr	-	12	
Turn-Off Delay Time		td(off)	-	85	
Fall Time		tf	-	35	
Input Capacitance	(VDS = -15 V, VGS = 0 V, f = 1 MHz)	Ciss	-	1435	pF
Output Capacitance		Coss	-	126	
Reverse Transfer Capacitance		Crss	-	113	

Note: 3. Pulse test: PW ≤ 300us ,duty cycle ≤ 2%.

4. Guaranteed by design, not subject to production testing.

6.ELECTRICAL CHARACTERISTICS CURVES

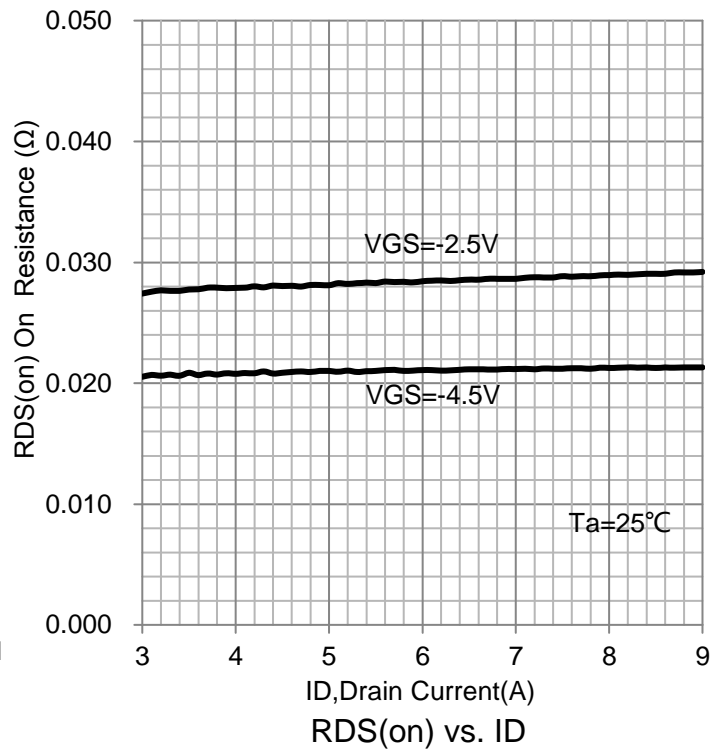
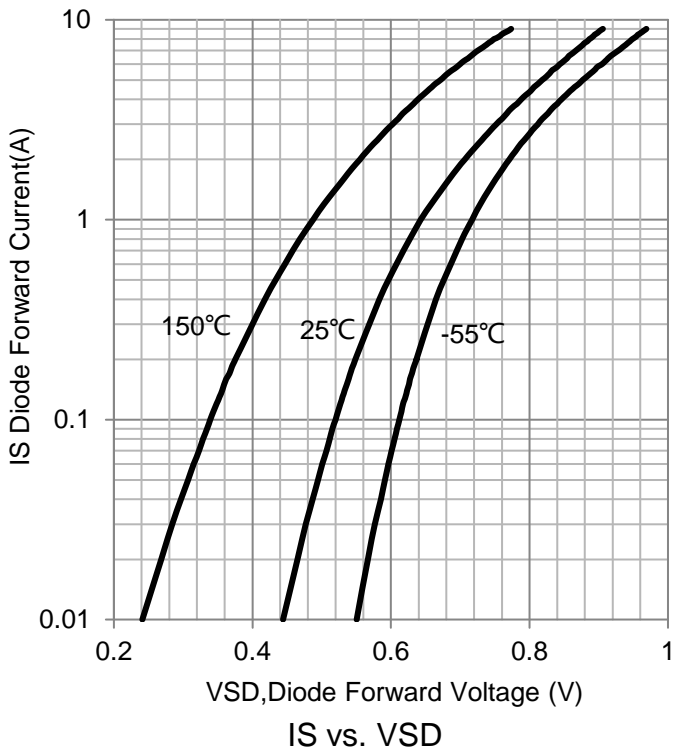
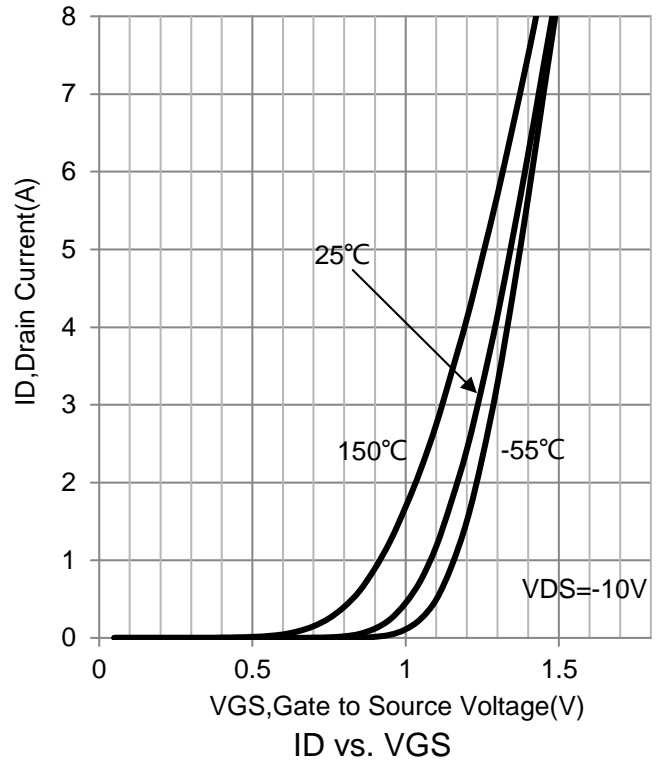
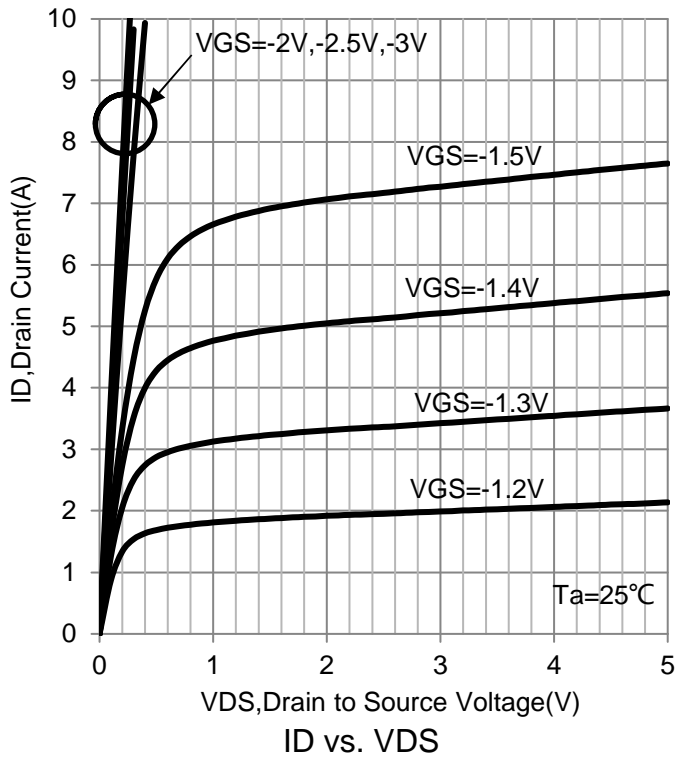

6.ELECTRICAL CHARACTERISTICS CURVES(Con.)

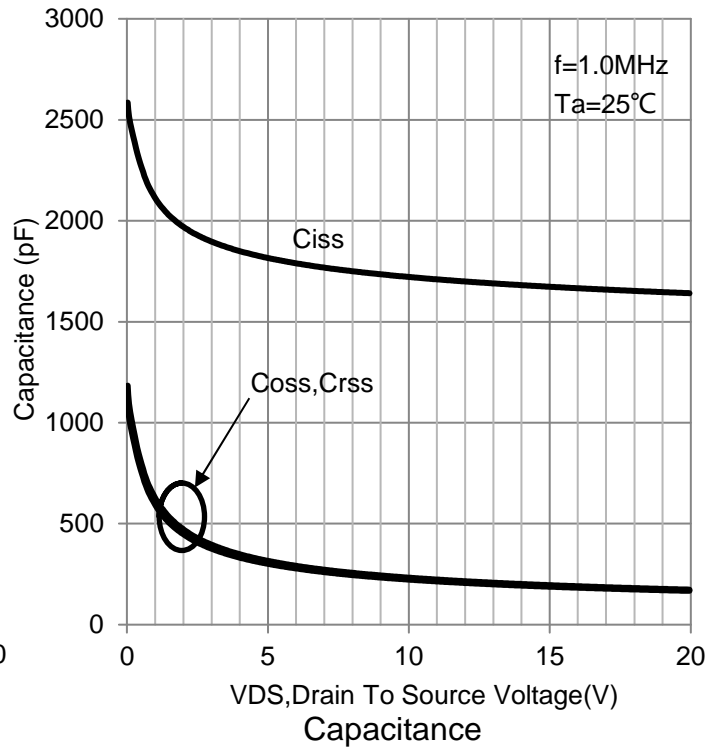
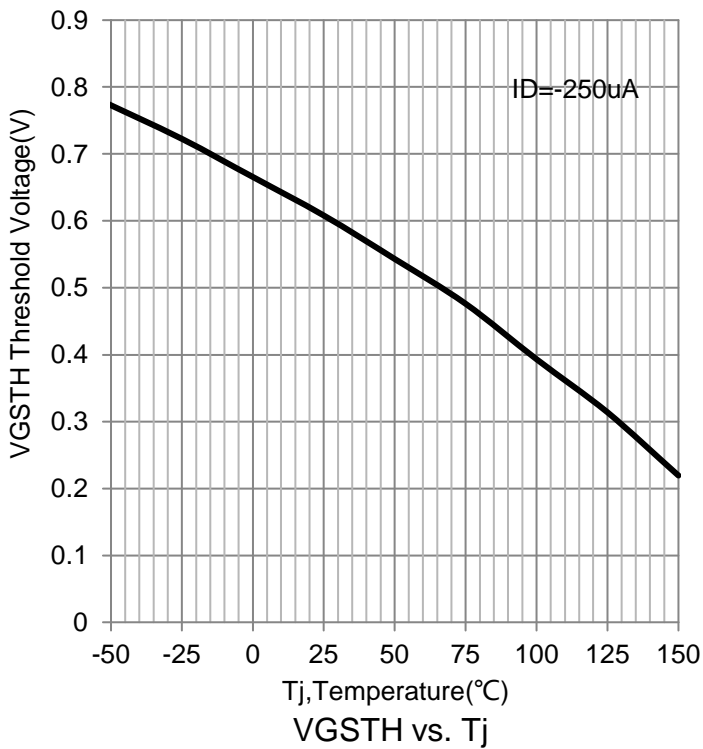
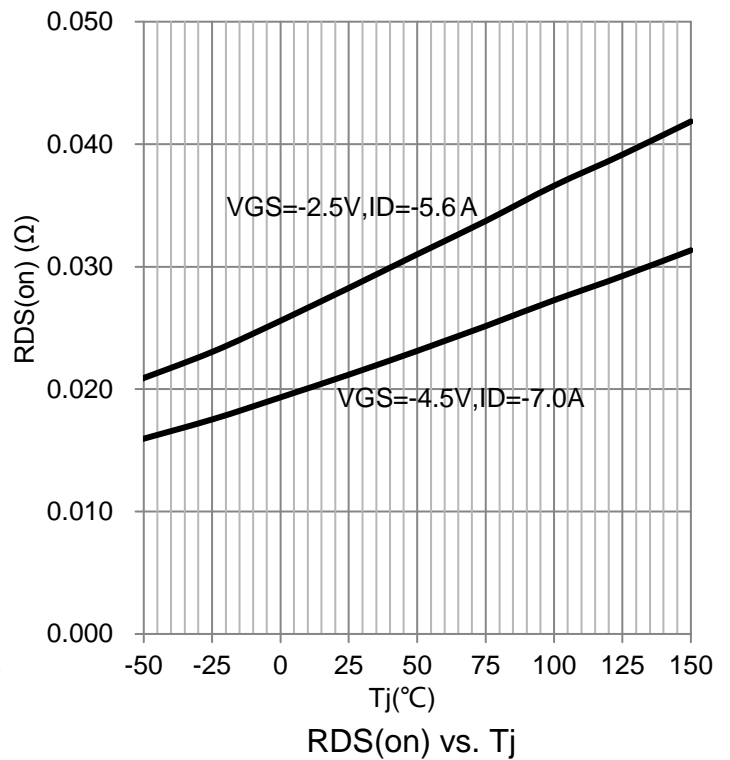
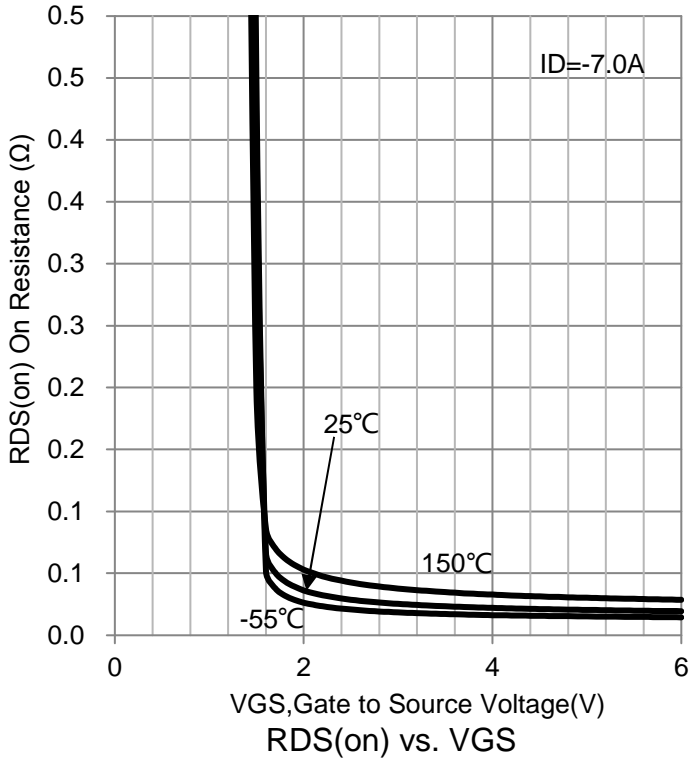

7. OUTLINE AND DIMENSIONS

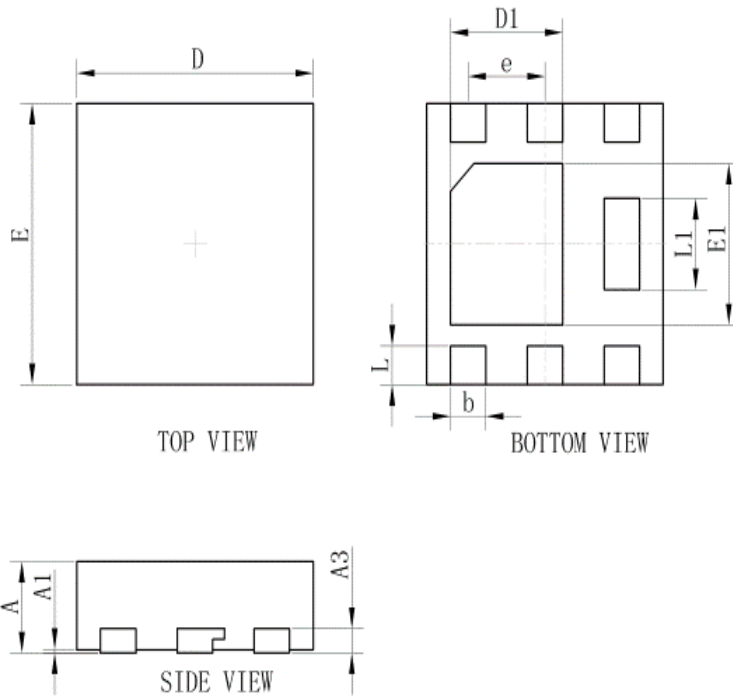

DFN2020-6S			
DIM	MIN	NOR	MAX
A	0.60	0.65	0.70
A1	0.01	0.03	0.05
b	0.25	0.30	0.35
D	1.95	2.00	2.05
E	1.95	2.00	2.05
e	0.65TYP.		
L	0.23	0.28	0.33
L1	0.60	0.65	0.65
D1	0.90	0.95	1.00
E1	1.10	1.15	1.20
A3	0.152REF		
All Dimensions in mm			

8 SOLDERING FOOTPRINT

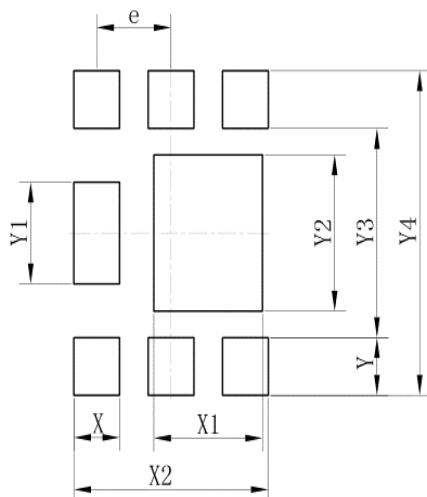

DFN2020-6S	
Dim	(mm)
X	0.40
X1	0.95
X2	1.70
e	0.65
Y	0.43
Y1	0.75
Y2	1.15
Y3	1.54
Y4	2.39

单击下面可查看定价，库存，交付和生命周期等信息

[>>LRC\(乐山无线电\)](#)