

# LBTP880DPTUG

## S-LBTP880DPTUG

PNP Power transistors

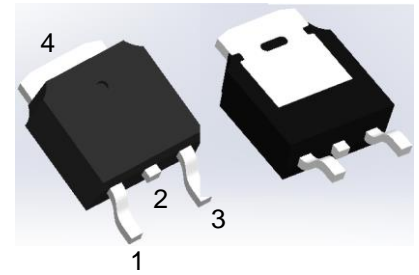

TO-252

### 1. FEATURES

- Lead Formed for Surface Mount Applications in Plastic Sleeves
- We declare that the material of product compliance with RoHS requirements and Halogen Free.
- S- prefix for automotive and other applications requiring unique site and control change requirements; AEC-Q101 qualified and PPAP capable.

### 2. DEVICE MARKING AND ORDERING INFORMATION

Device	Marking	Shipping
LBTP880DPTUG	P88	2500/Tape&Reel

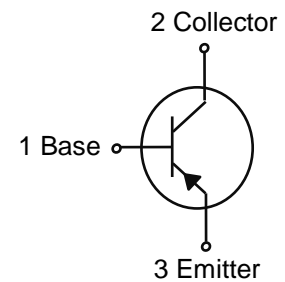

### 3. MAXIMUM RATINGS(Ta = 25°C)

Parameter	Symbol	Limits	Unit
Collector–Emitter Voltage	VCEO	-80	V
Collector–Base Voltage	VCBO	-80	V
Emitter–Base Voltage	VEBO	-5	V
Collector Current(DC)	IC	-8	A
Peak collector current(tp < 5 ms)	ICM	-16	A
Total Power Dissipation (Note 1) @ TA = 25°C	PD	1.75	W
Junction Temperature	Tj	150	°C
Storage Temperature Range	Tstg	-55~+150	°C

### 4. THERMAL CHARACTERISTICS

Parameter	Symbol	Limits	Unit
Thermal Resistance, Junction–to–Ambient(Note 1)	RθJA	71.4	°C/W

1. These ratings are applicable when surface mounted on the minimum pad sizes recommended.

**5. ELECTRICAL CHARACTERISTICS (Ta= 25°C)**

Characteristic	Symbol	Min.	Typ.	Max.	Unit
Collector–Emitter Breakdown Voltage (IC = -1 mA, IB = 0)	VBR(CEO)	-80	-	-	V
Collector–Base Breakdown Voltage (IC = -100μA, IE = 0)	VBR(CBO)	-80	-	-	V
Emitter–Base Breakdown Voltage (IE = -100μA, IC = 0)	VBR(EBO)	-5	-	-	V
Collector–Base Cutoff Current (VCB=-80V,IE=0 )	ICBO	-	-	-200	nA
Emitter–Base CutOff Current (VEB=-5V,IC=0)	IEBO	-	-	-200	nA
Collector-Emitter Cutoff Current (VCE=-80V,IB=0)	ICEO	-	-	-10	μA
DC Current Gain (VCE =-1V,IC =-2A) (VCE =-1V,IC =-4A)	HFE	60 40	- -	200 -	
Collector–Emitter Saturation Voltage (IC =-8A,IB =-400mA)	VCE(sat)	-	-	-1	V
Base-Emitter saturation voltage (IC =-8A, IB =-800 mA)	VBE(sat)	-	-	-1.5	V
Delay Time	(VCC=-15V,VBE=2V, IC=-1A,IB1=-0.1A)	td	-	43	ns
Rise Time		tr	-	85	
Storage Time	(VCC=-15V,IC=-1A, IB1=IB2=-0.1A)	ts	-	1500	
Fall Time		tf	-	117	

2.Pulse Test: Pulse Width  $\leq 300 \mu\text{s}$ , Duty Cycle  $\leq 2\%$ .

**6.ELECTRICAL CHARACTERISTICS CURVES**

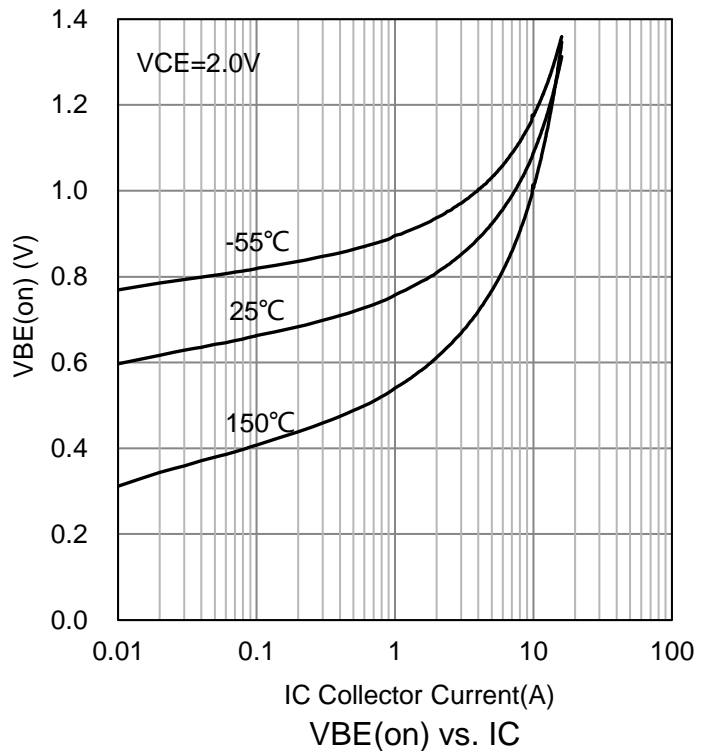
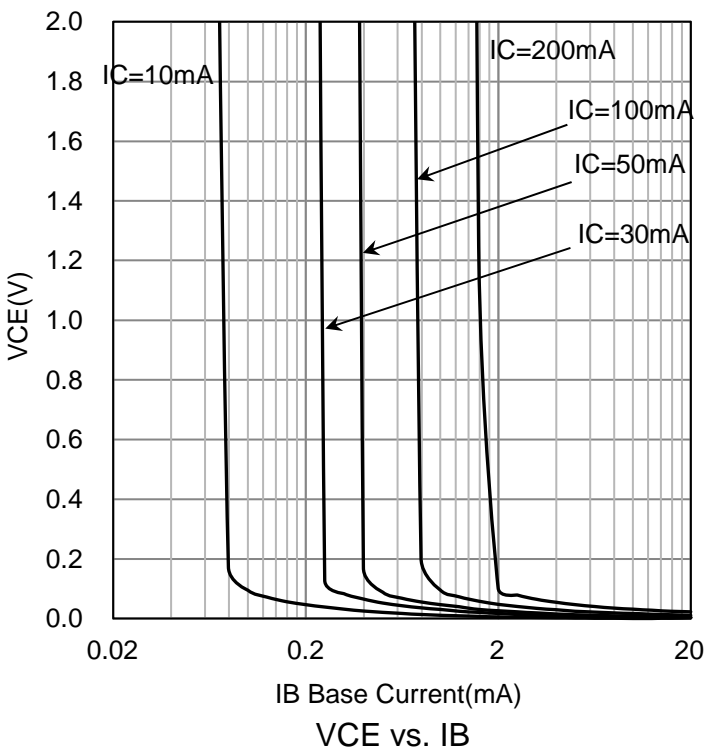
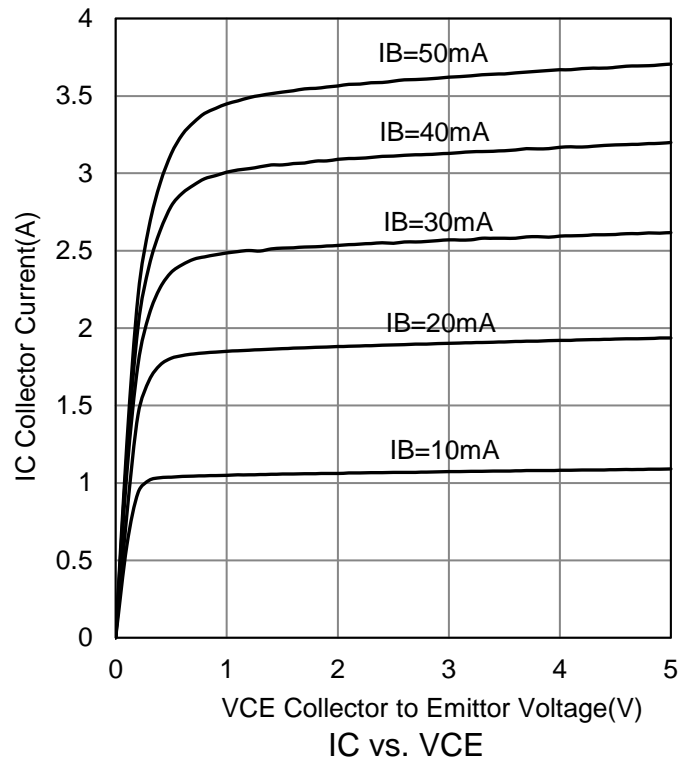
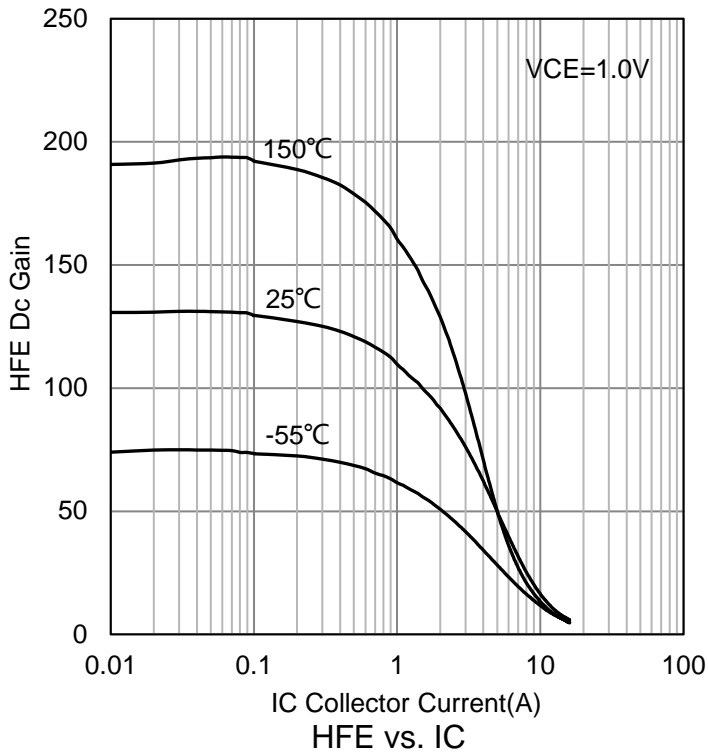

**6.ELECTRICAL CHARACTERISTICS CURVES(Con.)**

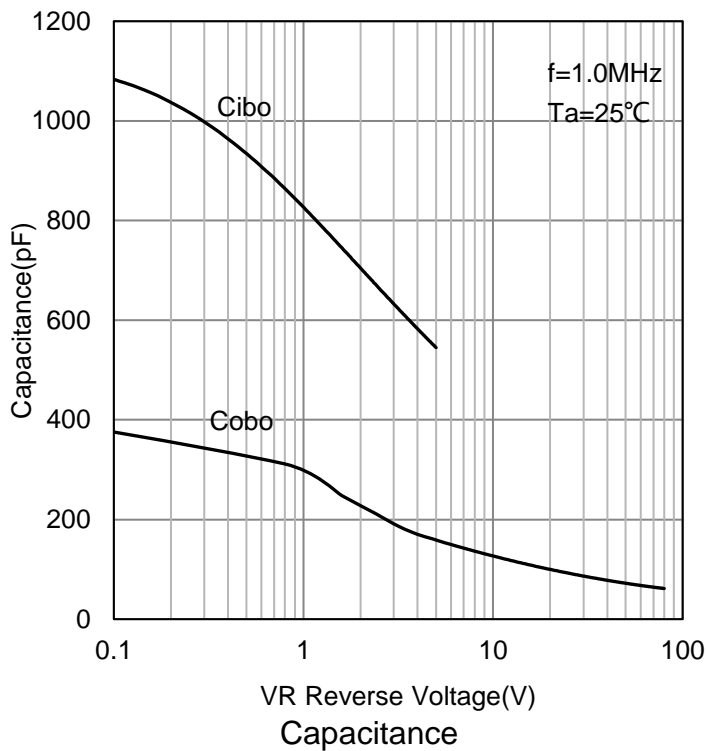
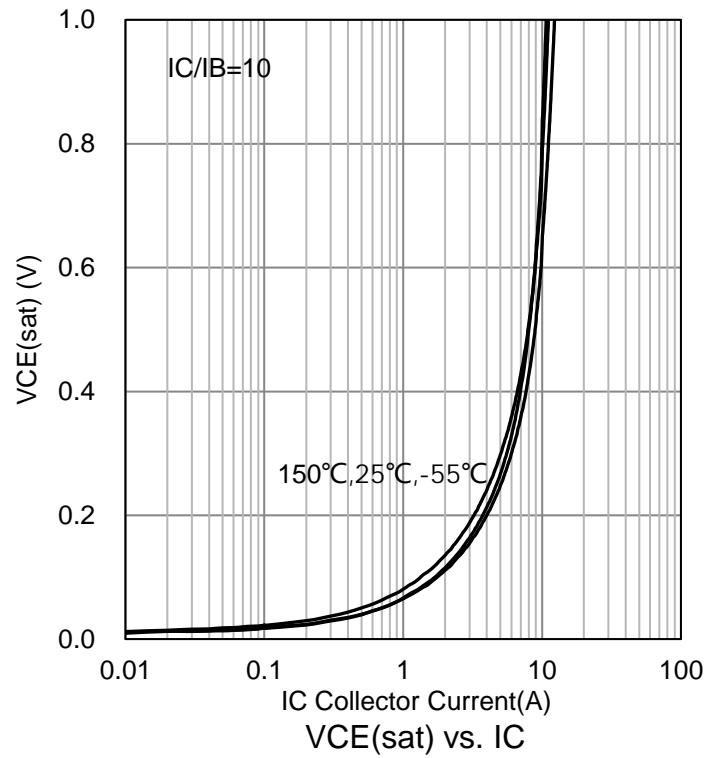
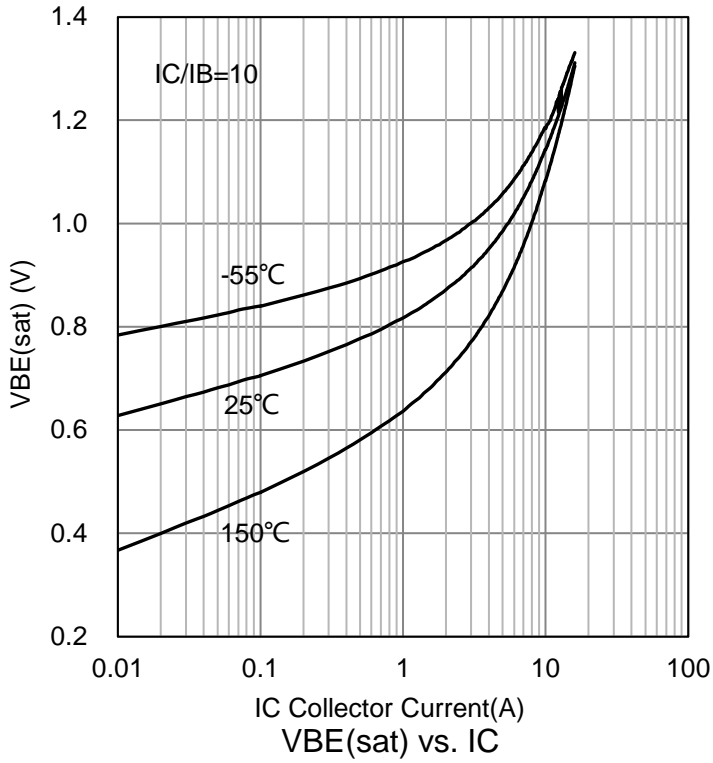

### 7.OUTLINE AND DIMENSIONS

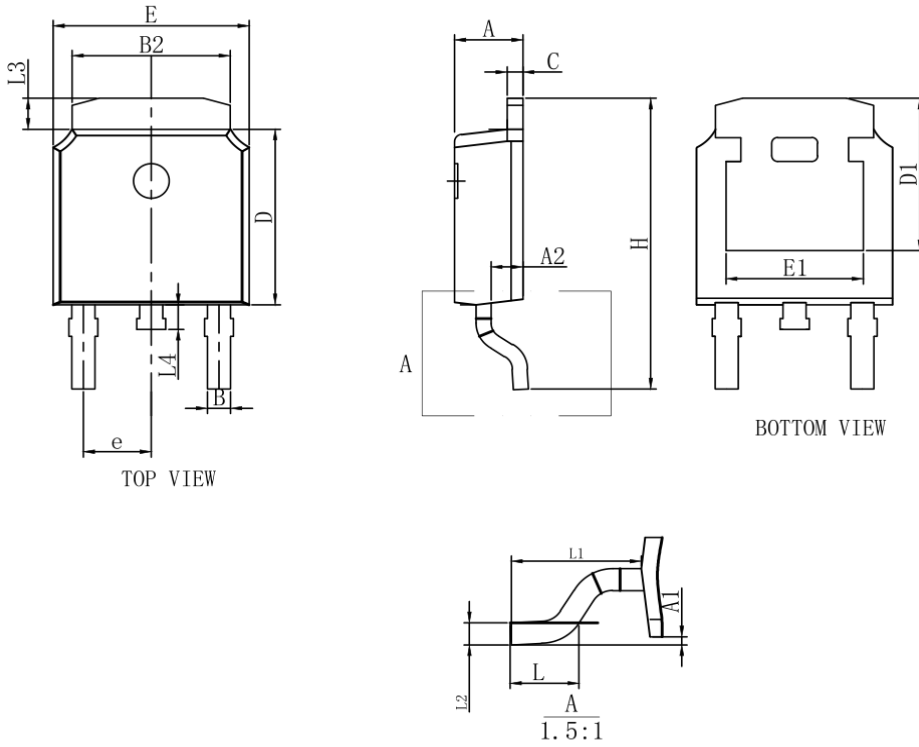

DIM	MILLIMETERS		
	MIN	NOM	MAX
A	2.15	2.30	2.45
A1	-	-	0.20
A2	0.90	1.07	1.17
B	0.68	0.78	0.88
B2	5.20	5.33	5.46
D	5.90	6.10	6.30
D1	5.30REF		
E	6.40	6.60	6.80
E1	4.63	4.83	5.03
e	2.286BSC		
H	9.85	10.10	10.35
L	1.30	1.50	1.70
L1	2.90REF		
L2	0.51BSC		
L3	0.88	1.08	1.28
L4	0.55	0.80	1.05

### 8.SOLDERING FOOTPRINT

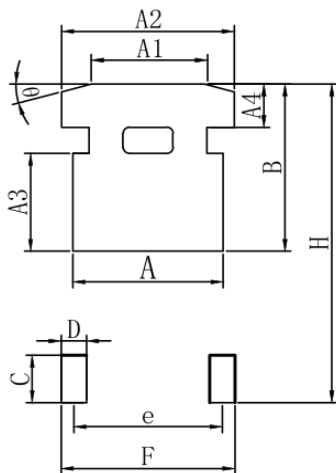

DIM	MIN(mm)
A	6.03
A1	4.50
A2	6.46
A3	4.10
A4	2.37
B	6.50
C	2.50
D	1.68
e	4.80
H	12.35
F	5.95

## **DISCLAIMER**

- Curve guarantee in the specification. The curve of test items with electric parameter is used as quality guarantee. The curve of test items without electric parameter is used as reference only.
- Before you use our Products for new Project, you are requested to carefully read this document and fully understand its contents. LRC shall not be in any way responsible or liable for failure, malfunction or accident arising from the use of any LRC's Products against warning, caution or note contained in this document.
- All information contained in this document is current as of the issuing date and subject to change without any prior notice. Before purchasing or using LRC's Products, please confirm the latest information with a LRC sales representative.

单击下面可查看定价，库存，交付和生命周期等信息

[>>LRC\(乐山无线电\)](#)