

GBU8B Thru GBU8M

High Current Glass Passivated Molding Single-Phase Bridge Rectifier

Reverse Voltage 100 to 1000V Forward Current 8A

FEATURES

- Plastic Package has Underwriters Laboratory Flammability Classification 94V-0
- High current capacity with small package
- Glass passivated chip junctions
- Superior thermal conductivity
- High IFSM



1. Maximum & Thermal Characteristics Ratings at 25°C ambient temperature unless otherwise specified.

Parameter Symbol	Symbol	GBU8B	GBU8D	GBU8G	GBU8J	GBU8K	GBU8M	Unit
Maximum repetitive voltage	VRRM	100	200	400	600	800	1000	V
Maximum RMS Voltage	VRMS	70	140	280	420	560	700	V
Maximum DC Blocking Voltage	VDC	100	200	400	600	800	1000	V
Maximum DC reverse current TA=25 °C	IR	5						μA
at rated DC blocking voltage TA=125°C		500						
Maximum average forward rectified output current at Tc=100°C	Io	8						A
Peak forward surge current 8.3ms single half sine-wave superimposed on rated load	IFSM	200						A
Rating of fusing (t<8.3ms)	I ² t	166						A ² sec
Dielectric strength terminals to case, AC 1 minute Current 1mA	Vdia	2.5						KV
Max instantaneous forward voltage at 4.0A	VF	1.05						V
Maximum thermal on P.C.B. without heat-sink	RθJA	MAX22						°C/W
resistance per leg on Al plate heat-sink	RθJC	MAX2.8						
Operating junction temperature	TJ	-55~150						°C
Storage temperature	Tstg	-55~150						°C
Mounting torque	Tor	Rating Torque : 0.8 (Suggests 0.45~0.65)						N.m

GBU8B Thru GBU8M

2. Ratings and Characteristic Curves (TA = 25°C unless otherwise noted)

Fig. 1 Derating Curve

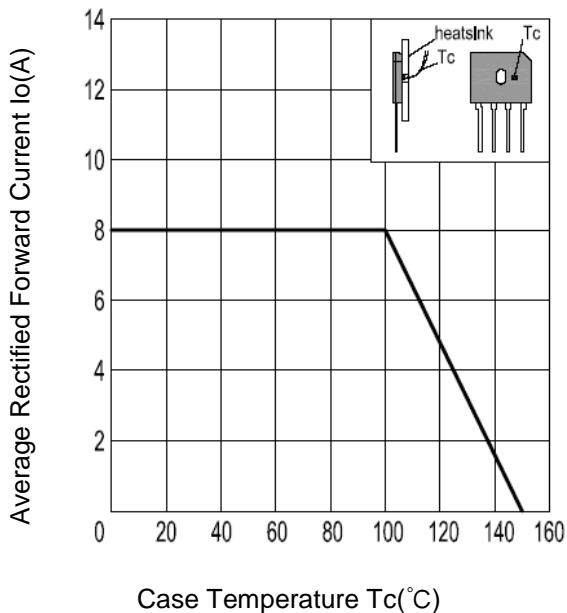

Fig.2 Typical Reverse Characteristics

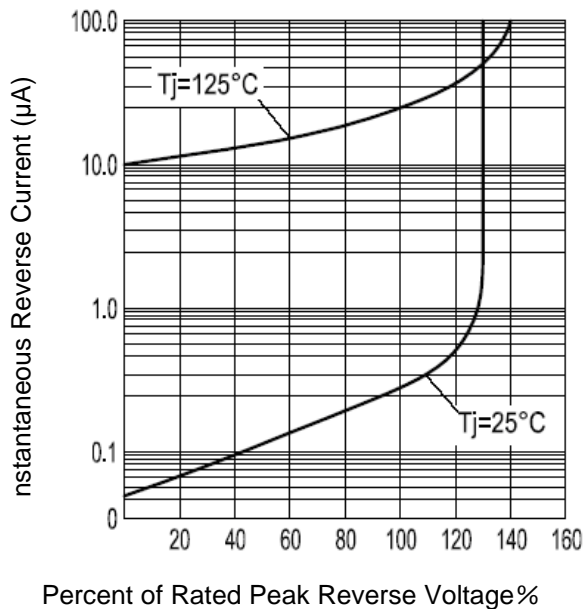

Fig.3 Forward Voltage

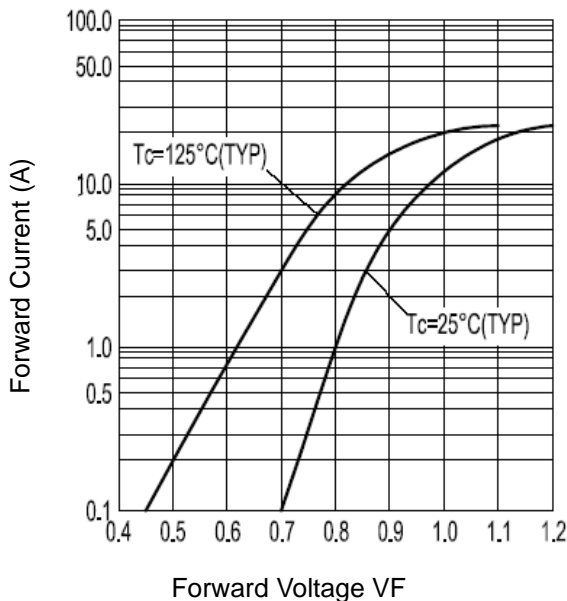
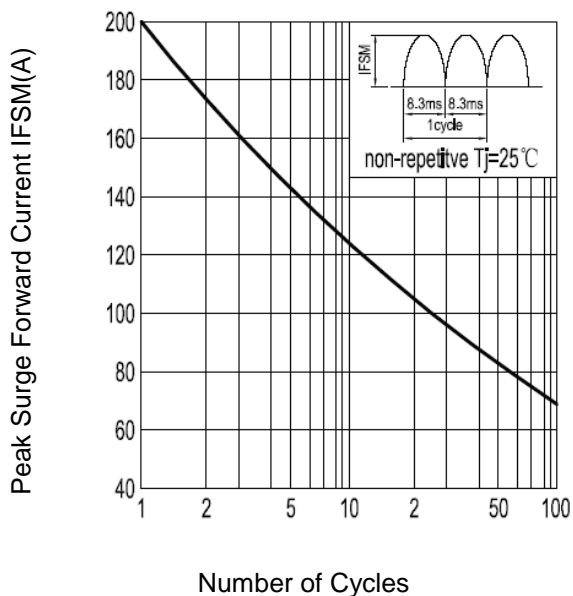
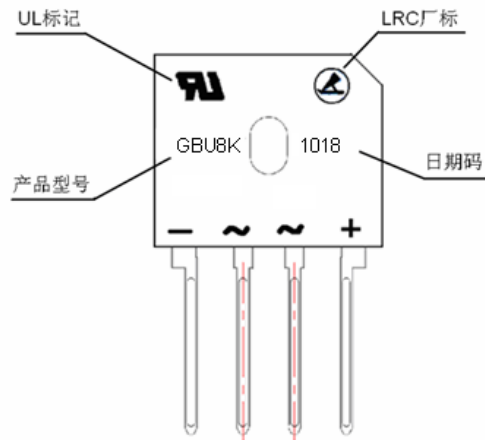

Fig.4 Peak Surge Forward Capability



GBU8B Thru GBU8M

3. Marking Identification



Note:

生产日期码包含4位数字，例如“1018”，前两个数字“10”表示为2010年，另外二个数字“18”是指第18周，即表示该产品为2010年18周生产。

型号:

GBU

8

K

bridge reverse voltage=800V

average rectified forward Current=8A

mean: GBU series bridge

4. Dimension

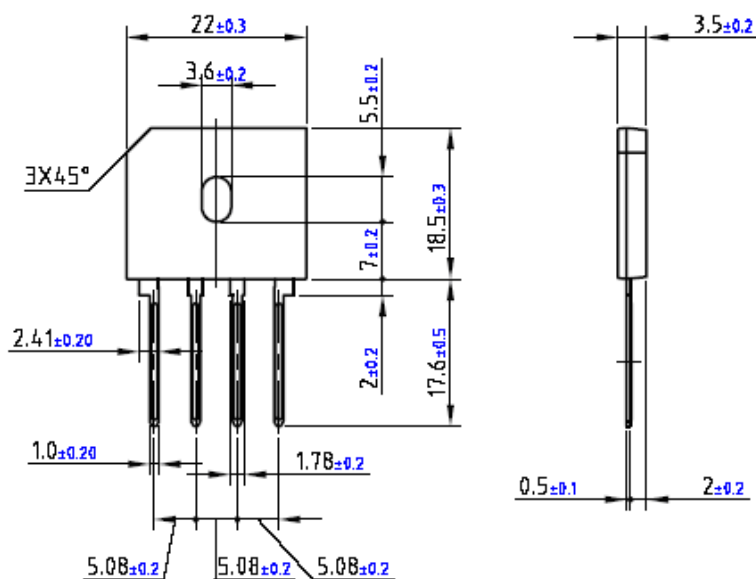

单击下面可查看定价，库存，交付和生命周期等信息

[>>LRC\(乐山无线电\)](#)