

LDN8205FT1G

N-Channel Enhancement Mode Power MOSFET

1. FEATURES

- $V_{DS} = 20V, I_D = 6.5A$
- $R_{DS(ON)} \leq 15 m\Omega, V_{GS} = 4.5V, I_{DS} = 6A$
- $R_{DS(ON)} \leq 22.5 m\Omega, V_{GS} = 2.5V, I_{DS} = 3A$
- We declare that the material of product compliance with RoHS requirements and Halogen Free.
- High power and current handling capability
- Lead free product is acquired
- Surface mount package

2. APPLICATIONS

- Battery protection
- Load switch
- Power management

3. DEVICE MARKING AND ORDERING INFORMATION

Device	Marking	Shipping
LDN8205FT1G	211	3000/Tape&Reel
LDN8205FT3G	211	10000/Tape&Reel

4. Absolute Maximum Ratings (TA =25 °C unless otherwise noted)

Parameter	Symbol	Limits	Unit
Drain-Source Voltage	V_{DS}	20	V
Gate-Source Voltage	V_{GS}	± 10	V
Drain Current-Continuous	I_D	6.5	A
Drain Current-Pulsed (Note1)	I_{DM}	26	A
Maximum Power Dissipation	P_D	1.5	W
Operating Junction and Storage Temperature Range	T_J, T_{STG}	-55 ~ +150	°C

Note:1. Repetitive Rating: Pulse width limited by maximum junction temperature.

5. THERMAL CHARACTERISTICS

Parameter	Symbol	Limits	Unit
Thermal Resistance, Junction-to-Ambient (Note 2)	$R_{\theta JA}$	83	°C/W

Note:2. Surface Mounted on FR4 Board, $t \leq 10$ sec.

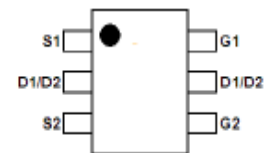
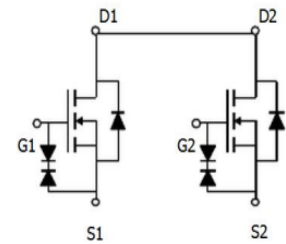
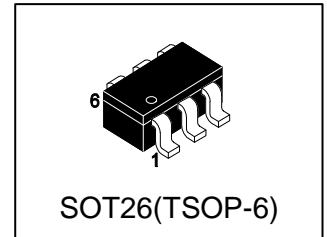

6. ELECTRICAL CHARACTERISTICS (Ta= 25°C)

Parameter	Symbol	Min.	Typ.	Max.	Unit
Off Characteristics					
Drain-Source Breakdown Voltage (VGS =0V ID =250μA)	BVDSS	20	-	-	V
Zero Gate Voltage Drain Current (VDS =16V,VGS =0V)	IDSS	-	-	1	μA
Gate-Body Leakage Current (VGS =± 10V,VDS =0V)	IGSS	-	-	± 10	μA
On Characteristics (Note 3)					
Gate Threshold Voltage (VDS =VGS ,ID =250μA)	VGS(th)	0.5	0.7	1.2	V
Drain-Source On-State Resistance (VGS =4.5V, ID =6A)	RDS(ON)	-	13	15	mΩ
(VGS =3.1 V, ID =5A)		-	14	17	mΩ
(VGS =2.5V, ID =3A)		-	16.5	22.5	mΩ
Forward Transconductance (VDS =5V,ID =4.5A)	gFS	-	10	-	S
Dynamic Characteristics (Note4)					
Input Capacitance (VDS =10V,VGS =0V,F=1.0MHz)	Ciss	-	1300	-	PF
Output Capacitance (VDS =10V,VGS =0V,F=1.0MHz)	Coss	-	290	-	PF
Reverse Transfer Capacitance (VDS =10V,VGS =0V,F=1.0MHz)	Crss	-	150	-	PF
Switching Characteristics (Note 4)					
Turn-on Delay Time (VDD =10V,ID =1A VGS =4.5V,RGEN =6 Ω)	td(on)	-	30	-	nS
Turn-on Rise Time (VDD =10V,ID =1A VGS =4.5V,RGEN =6 Ω)	tr	-	21	-	nS
Turn-Off Delay Time (VDD =10V,ID =1A VGS =4.5V,RGEN =6 Ω)	td(off)	-	75	-	nS
Turn-Off Fall Time (VDD =10V,ID =1A VGS =4.5V,RGEN =6 Ω)	tf	-	40	-	nS
Total Gate Charge (VDS =10V,ID =6A, VGS =4.5V)	Qg	-	12	-	nC
Gate-Source Charge (VDS =10V,ID =6A, VGS =4.5V)	Qgs	-	2.3	-	nC
Gate-Drain Charge (VDS =10V,ID =6A, VGS =4.5V)	Qgd	-	1	-	nC
Drain-Source Diode Characteristics					
Turn-On Delay Time (VGS =0V,IS =1.0A)	VSD	-	0.75	1.5	V
Diode Forward Current (Note2)	IS	-	-	1.0	A

Note: 3. Pulse Test: Pulse Width ≤ 300μs, Duty Cycle ≤ 2%.

4. Guaranteed by design, not subject to production

7. OUTLINE AND DIMENSIONS

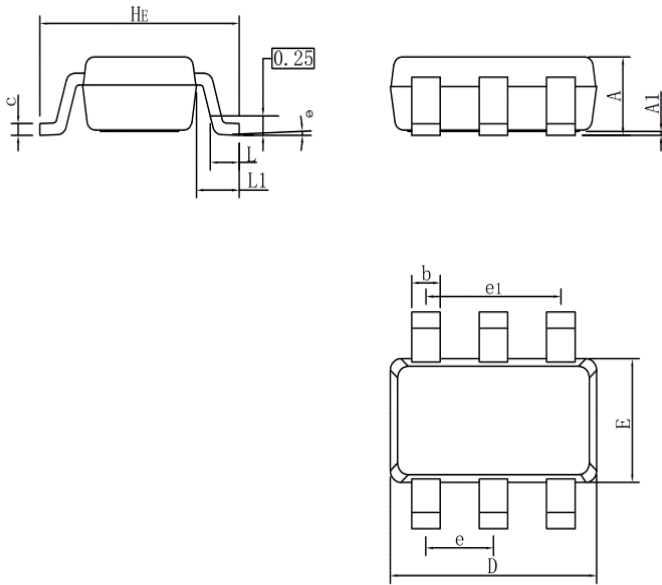

SOT26			
DIM	MIN	NOR	MAX
A	0.90	1.00	1.10
A1	0.01	0.06	0.10
b	0.30	0.40	0.50
c	0.10	0.17	0.20
D	2.80	2.90	3.00
E	1.50	1.60	1.70
e	0.85	0.95	1.05
e1	1.80	1.90	2.00
L	0.20	0.40	0.60
L1	0.60REF		
HE	2.60	2.80	3.00
θ	0°	-	10°

8. SOLDERING FOOTPRINT

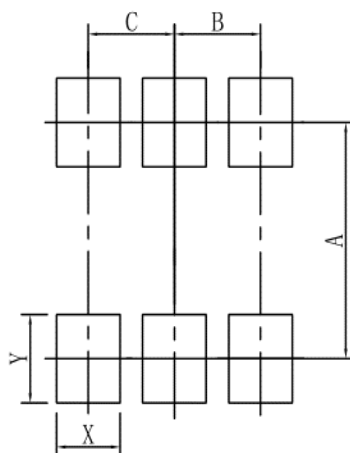

SOT26	
DIM	(mm)
X	0.70
Y	0.90
A	2.40
B	0.95
C	0.95

单击下面可查看定价，库存，交付和生命周期等信息

[>>LRC\(乐山无线电\)](#)